

Section 4 – Electrical

General Specifications	3
Torque Specifications	4
Description and Operation	5
Regenerative Braking System (RBS).....	6
Acids	7
Electric Shock	7
Key Replacement	8
Energy Tips.....	8
EV-Specific Precautions	9
Safety	9
Rubber Insulating Gloves Testing.....	9
Buffer Zone	10
Fuses/Relays.....	13
Warning Labels.....	15
Harness Routing.....	19
Battery Charging.....	21
Diagnosis and Testing.....	23
Diagnostic Trouble Code Information	23
Basic Troubleshooting Information	26
Power Distribution	39
Ground Distribution	44
Electrical Leakage Detection	47
Accelerator Potentiometer.....	55
Required Tools.....	58
Battery.....	67
Charging.....	74
Voltage Step Down.....	81
Exterior Lamps.....	86
Heater/Defogger.....	104

Horn	113
Instrument Cluster Gauge	119
Motor and Motor Controller	151
Power Point	178
Wiper/Washer	183
Connector End Views	191
Removal and Installation	210
Accelerator/Potentiometer	210
Batteries	210
Charger.....	213
Contactor.....	215
Controller, Motor	216
Converter 1, DC/DC -Standard.....	217
Converter 2, DC/DC - Optional	217
Instrument Cluster Gauge	218
Headlamp	220
Headlamp Bulb	221
Motor.....	224
Motor, Wiper.....	225
Heater/Defogger System Components.....	227
Heater/Defogger Assembly.....	229
Heater/Defogger Switch.....	230
Heater/Defogger Contactor.....	231
Heater/Defogger Duct and Hose.....	232
Power Point, 15A DC/DC.....	233
Electronic Flasher	234
Temperature Sensor	234
Switch, Drive Mode Selector	235
Switch, Horn	236
Switch, Multifunction	237
Switch, Service Disconnect.....	238
Front Turn Signal	238

Rear Turn Signal	239
Wiring Harnesses – 12V	240
Wiring Harnesses – 72V (Front of vehicle)	240
Wiring Harnesses – 72V (Mid vehicle)	241
Wiring Harnesses – 72V (Rear of vehicle)	242
General Procedures	243
Battery Charging	243
Vehicle Storage -- Battery	247
Power Shutdown Procedure	249
Battery Water Reminder Indicator Resetting (Flooded Batteries Only)	254
Battery Type Reprogramming	255
Headlamp Adjustment	255

General Specifications

Battery Specifications		
Maintenance Free (Gel Type) Battery		
Description	Specification	
Type Number	8G31	
Voltage	12	
Cold Cranking Amps (CCA) @ 0° F	550	
Approximate Weight Lbs (Kgs)	71.7 (32.5)	
Dimensions (LxWxH) In (mm)	12 ^{15/16} x 6 ^{3/4} x 9 ^{3/8} (329x171x238)	
Flooded (Water Filled) Battery		
Description	Specification	
Type Number	31XHS	
Voltage	12	
Cold Cranking Amps (CCA) @ 0° F	550	
Approximate Weight Lbs (Kgs)	67 (30)	
Dimensions (LxWxH) In (mm)	13 x 6 ^{3/4} x 9 ^{1/2} (331x171x242)	
Lubrication Specifications		
Description	Part Number	Ford Specification

Electrical Grease	F8AZ-19G208-AA	WSB-M1C239-A
-------------------	----------------	--------------

Torque Specifications

Description	Nm	Lb-Ft	Lb-In
Accelerator pedal bracket bolts	24-31	18-22	
Battery hold-down strap bolts	24-28	18-20	
Battery hold-down strap nuts	8		70
Battery hold-down bracket	24-28	18-20	
Battery charger bolt	24-28	18-20	
Battery cable clamp nuts	12-15		107-132
Battery cable to contactor nut	8-10		71-88
Brake lamp screws	2-2.7		18-23
Bumper bolts – Rear	3.3		29
Contacto lower cable nut	8-10		71-88
Contacto upper cable nut	8-10		71-88
Chassis connector bolt	24-31	18-22	
Front turn signal bracket bolt	24-31	18-22	
Front turn signal bolts	8-10		71-88
“H” frame bolts	20-30	15-22	
Headlamp bracket bolt	24-31	18-22	
Headlamp to bracket screws	3.3-4.9		29-43
Heater/defogger contactor cable nuts	8-10		71-88
Heater/defogger switch nuts	1.75-2.25		15.4-19.9
Heater/defogger bracket bolts	23.3-31.7	17.1-23.3	
High mount stop lamp screws	3.3		29
High mount stop lamp lens screws	1.9-2.7		17-23
Horn bolts	23-31	17-22	
Instrument cluster gauge screws	0.85-1.15		7.5-10.1
Multifunction switch screw	2.5-3.7		22.1-32.7
Rear turn signal screws	1.9-2.7		17-23

Description	Nm	Lb-Ft	Lb-In
Steering column shroud screws	2.7-3.7		23.8-32.7
Washer bottle bolts	7-10		62-88
Wiper motor upper bracket bolts	24-28	18-20	
Wiper motor to lower bracket nut	5-7		45-61
Wiper motor lower bracket bolt	5-7		45-61
Wiper motor shaft nut	4-5		35-44

Description and Operation

The main functions of the electrical system are to power and move the vehicle. The main components of the electrical system are the six batteries, wiring harnesses, motor, motor controller and instrument panel gauge.

There are six 12V batteries connected in series. 72V power is supplied to the charger at all times, even when the service disconnect switch is in the OFF position. Low amperage 72V is supplied at all times to the motor, motor controller and gauge. When the drive mode selector switch is moved to the R (Reverse), D (Drive) or T (Turf) position, the instrument cluster gauge supplies the +72V power to the motor controller, which in turn closes the contactor coil. High amperage is supplied through the closed contactor contacts to the motor controller. The motor controller then supplies regulated power to the motor to move the vehicle.

The battery-charging rate is determined by type of battery selected via the instrument cluster gauge and ambient temperature. A temperature sensor located by the battery pack reads the ambient temperature around the battery pack. When the temperature sensor reads extremely high ambient temperatures [120°F (49°C) or higher] the charging rate will be limited to 8 amps until the temperature reduces in turn increasing the amount of time necessary to charge the vehicle. The type of battery selected in the instrument cluster gauge must correspond to the type of batteries installed in the vehicle. Damage to the batteries could occur if the type of battery programmed in the instrument cluster gauge is incorrect.

The motor controller monitors battery pack voltage while the vehicle is being operated. If the battery pack voltage drops below 68V while driving, the vehicle will continue to operate, but will not restart. A Diagnostic Trouble Code (DTC) will be set if the key is cycled OFF, and then to R, T or D. The motor controller is programmed not to allow the vehicle to operate if the battery pack voltage drops below 68V. If the battery pack voltage drops below 55V, current to the motor will be limited and the vehicle may cease to operate.

The motor controller monitors a variety of parameters during driving. DTCs related to motor controller faults are covered in the Diagnosis and Testing subsection of this section. The motor is connected to the motor controller by four cables: A1 and A2 (armature) and F1 and F2 (field). These cables must be properly attached in order for the vehicle to operate properly.

Battery life is determined by capacity. Battery capacity cannot be accurately measured by any equipment available in the field. Load testing and measuring cold cranking amps (CCA) will however allow an assessment as to whether a battery has a suspect cell.

To maximize battery pack life, the capacities of the individual batteries must be closely matched. Within the first 50 cycles (approximately one month in service), battery capacity remains relatively constant. After this point, however, battery capacity will begin to drop. A pack, which contains batteries of widely varying capacity, will experience premature failure. For this reason, individual batteries may only be replaced within the first month in service, and replaced as a pack after that time.

Low voltage (12V) power is supplied from the DC/DC converter for lighting, horn, turn signals and instrument cluster gauge backlighting. The horn, brake lights and hazards are powered at all times. Vehicles equipped with the optional powerpoint are equipped with a second DC/DC converter than powers only the powerpoint. The optional powerpoint is powered at all times.

When troubleshooting the electrical systems, always remain aware of the systems, which are powered under the conditions existing during testing. When performing diagnostic procedures on the vehicle when the vehicle power has not been turned off, use High Voltage Insulated Gloves 100-F036 or equivalent and Face Shield 100-F035 or equivalent for protection. When replacing a component on the 72V harness or interfaced to the 72V harness, turn the vehicle power off using the [Power Shutdown Procedure](#) in this section to avoid risk of electric shock or injury while working on the vehicle. When

Regenerative Braking System (RBS)

The vehicle is equipped Regenerative Braking System (RBS). The RBS is designed to utilize the vehicle's forward motion to generate electricity and partially recharge the batteries for a nominal increase in driving range. The RBS works when you are not applying the accelerator. Once the accelerator pedal is released, the vehicle automatically and slowly decelerates. This deceleration is caused by using the spinning motor as a generator to create electrical current. This recharges the battery pack and slows the vehicle. The RBS works only when the vehicle is traveling at 18 mph (29 km/h) or greater. When driving down hills, regenerative braking may be used to maintain speed while recovering energy similar to the way engine braking is typically used. When the battery is fully charged, regenerative braking is eliminated to prevent overcharging of the batteries. Regenerative braking does not take the place of the standard friction brakes; it only assists them.

CAUTION:

If the battery pack is fully charged, RBS will not be enabled because the battery pack cannot accept the additional current. The contactor is designed to open if the battery pack voltage exceeds 95V. Avoid driving situations where you will be driving down steep grades with a fully charged battery pack or the drive system and RBS will shut down. The standard braking system is not affected but speeds may exceed 25 mph (40 kp/h). If this should occur, apply the brakes to reduce and maintain speeds below 25 mph (40 kp/h).

Acids

WARNING!

LEAD-ACID BATTERIES CONTAIN SULFURIC ACID. AVOID CONTACT WITH SKIN, EYES OR CLOTHING. ALSO, SHIELD YOUR EYES WHEN WORKING NEAR BATTERIES TO PROTECT AGAINST SPLASHING OF THE ACID SOLUTION. IN CASE OF ACID CONTACT WITH THE SKIN OR EYES, FLUSH IMMEDIATELY WITH WATER FOR A MINIMUM OF FIFTEEN MINUTES AND GET PROMPT MEDICAL ATTENTION. IF ACID IS SWALLOWED, DRINK LARGE QUANTITIES OF MILK OR WATER, FOLLOWED BY MILK OF MAGNESIA, A BEATEN EGG, OR VEGETABLE OIL. CALL A PHYSICIAN IMMEDIATELY.

The battery pack is composed of 6 12-volt lead acid batteries wired in series. These batteries are similar in design to the battery in a gasoline-powered vehicle. The batteries contain sulfuric acid, which can cause severe skin or eye damage if allowed to contact these areas. Follow all safety precautions outlined in the EV-Specific Precautions prior to working on the battery pack.

WARNING!

BATTERIES NORMALLY PRODUCE EXPLOSIVE GASES WHICH CAN CAUSE PERSONAL INJURY OR DEATH. DO NOT ALLOW FLAMES, SPARKS OR LIGHTED SUBSTANCES TO COME NEAR THE BATTERIES. WHEN CHARGING OR WORKING NEAR THE BATTERIES, ALWAYS SHIELD YOUR FACE AND PROTECT YOUR EYES. ALWAYS PROVIDE ADEQUATE VENTILATION.

Electric Shock

WARNING!

THE BATTERY PACK ASSEMBLY CAN DELIVER IN EXCESS OF 72 VOLTS OF DC POWER. IMPROPER HANDLING OF THE BATTERY PACK CAN RESULT IN INJURY OR FATALITY. ONLY AUTHORIZED PERSONNEL TRAINED TO WORK WITH BATTERY PACK COMPONENTS ARE PERMITTED TO HANDLE THE BATTERIES.

There are two electrical systems on the EV. A 72V high voltage system is used to power the motor/gearbox. Orange color or orange wrapping on the harness bundle identifies high voltage wiring contained within the bundle. Components that have larger connectors, orange coverings on the wires, or warning labels contain or carry high voltage. A 12V system is used to operate the standard systems such as headlamps, windshield wipers and turn signals. These components should be treated with extreme caution. Do not perform any service on them until all system warnings and cautions are read and understood.

Key Replacement

The keys for the TH!NK neighbor require special adapter kits to cut new keys on existing key cutting machines. When using Rotunda Exacta Key Machine 011-00215, or equivalent the Rotunda TH!NK Neighbor AE Exacta Accessory Kit 011-00270 should be used. When using Rotunda 029A Key Machine Code & Duplicator 011-00263, or equivalent the Rotunda TH!NK Neighbor 029A Accessory Kit 011-00271 should be used.

Energy Tips

The range the vehicle can travel is affected by:

- The use of vehicle accessories.
- Driving habits
- Type of tire (Turf tires reduce vehicle range)
- Weather conditions.
- Age of battery pack.
- Climbing steep terrain.
- Driving off-road.

To maximize the vehicle's range, follow these steps:

- Keep the tires properly inflated.
- Keep payloads as light as possible.
- Avoid frequent full throttle usage.
- Maintain a steady speed while driving.
- Cruise at moderate speeds.
- Select routes that minimize the number of starts and stops encountered.
- Charge the vehicle after every use.

EV-Specific Precautions

When working on the 72-volt system the following precautions must be taken.

1. A buffer zone must be placed around the vehicle.
2. Rubber insulating gloves must be worn.
3. A face shield must be worn to shield the face and protect the eyes from electric arc.

Safety

Throughout this service manual there are paragraphs that are marked with a title of **WARNING**, or **CAUTION**. These special paragraphs contain specific safety information, and must be read, understood, and heeded before continuing the procedure, or performing the step(s).

WARNING!

A WARNING INDICATES AN IMMEDIATE HAZARD, WHICH COULD RESULT IN SEVERE PERSONAL INJURY OR DEATH.

CAUTION:

A Caution indicates conditions that could result in damage to the vehicle or other property.

A third special paragraph that appears throughout this service manual is marked with the title of “Note”

A “Note” is a paragraph that describes essential service or maintenance information that relates to a particular step(s) or procedure. The “Note” must be read, understood and heeded before continuing with the procedure, or performing the step(s).

Note:

A note contains additional information to make the procedure, or step(s), more easily understood or implemented. Or it may contain essential maintenance information to assure proper operation of the vehicle.

Rubber Insulating Gloves Testing

Note:

The rubber insulating gloves that are to be worn while working on the high voltage system are rated for use on equipment of up to 1000 volts. They must be inspected before each use and must always be worn in conjunction with the leather outer glove. Any hole in the rubber-insulating glove is a potential entry point for high voltage.

1. Roll the glove up from the open end until the lower portion of the glove begins to balloon from the resulting air pressure. If the glove leaks any air it must not be used.
2. The gloves should not be used if they exhibit any signs of wear and tear.
3. The leather gloves must always be worn over the rubber insulating gloves in order to protect them.
4. The rubber insulating gloves must be class "O" and meet all of the American Safety Testing Materials Standards.

Buffer Zone

Note:

The buffer zone is required only when working on the 72-volt system.

1. Position the vehicle in the service bay.
2. Position four orange cones around the corners of the vehicle to mark off a 1m (3ft) perimeter around the vehicle.
3. Do not allow any unauthorized personnel into the buffer zone during repairs involving high voltage. Only personnel trained for service on the high voltage system are to be permitted in the buffer zone.

The service disconnect switch location was modified mid year. Refer to the following.

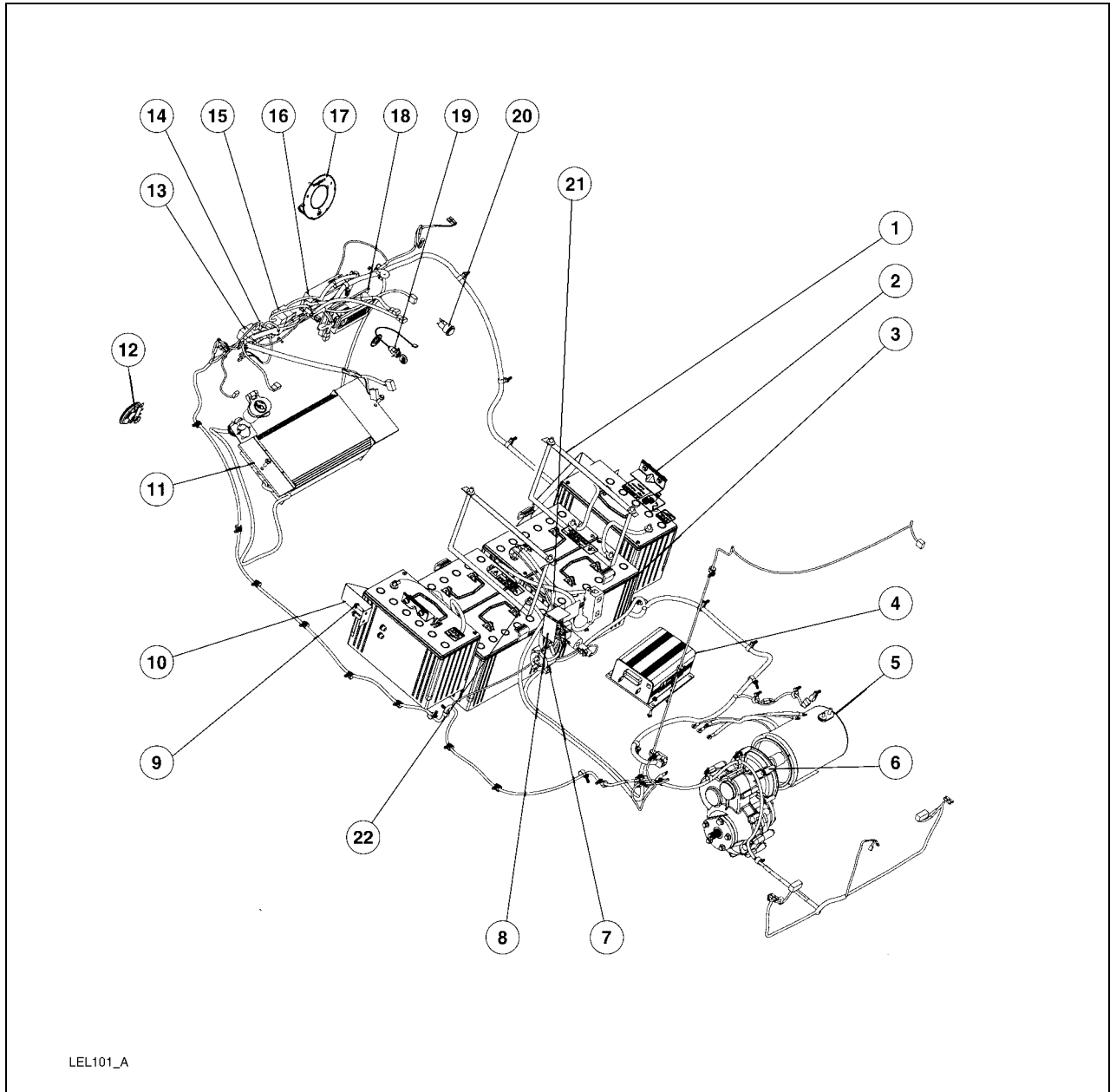

LEL101_A

Item	Part Number	Description
1	10718	Battery Mounting Strap
2	10755	Battery Mounting Bracket
3	10655	Battery (one of six)
4	14B298	Motor Controller
5	14B280	Motor

Item	Part Number	Description
6	7002	Gearbox
7	14B267	Contactactor
8	Part of 14401	Service Disconnect Switch
9	--	Battery Mounting Strap Bolt
10	10753	Battery Mounting Strap
11	10B689	Battery Charger
12	13832	Horn
13	--	Relay - Horn
14	--	Fuses
15	--	Relay – DC/DC
16	14B227	DC/DC Converter 1 (standard)
17	045D27	Instrument Cluster Gauge Face Plate
18	14B227	DC/DC Converter 2 (optional)
19	Part of 22050	Drive Mode Selector Switch
20	19N236	Power Point – Optional
21	--	Battery Pack Negative
22	--	Battery Pack Positive

Fuses/Relays

The fuses and relays shown are located at the front of the vehicle. Remove the hood to access them.

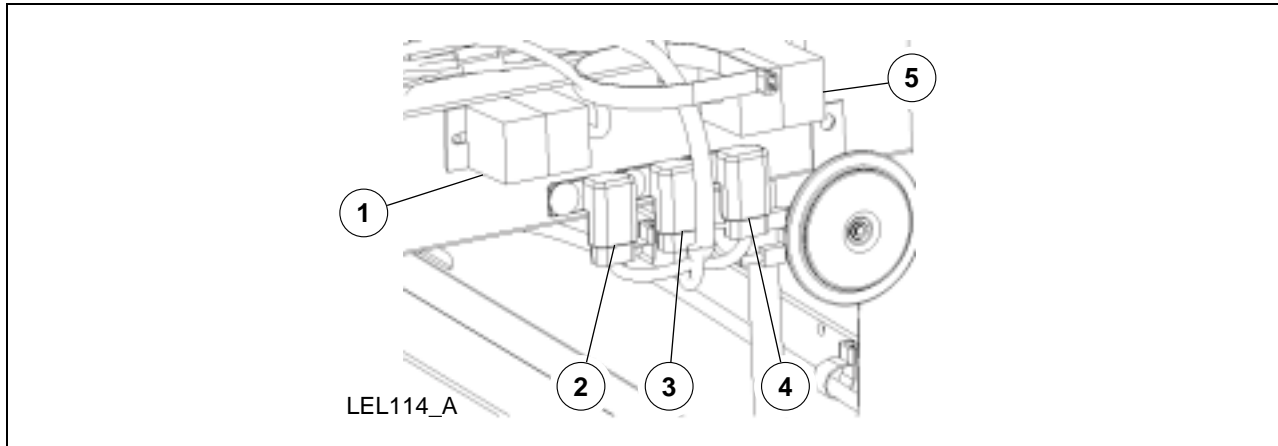

Item	Fuse Amp Rating	Description
1	--	Relay – DC/DC
2	20A	Brake, Flasher, Horn
3	20A	Lights
4	10A	Wiper, Washer
5	--	Horn Relay

The 400A megafuse located under the seat stanchion cover is not serviced separately. When servicing the 400A megafuse, you must replace the 400A megafuse and the attached harness as an assembly.

Switch shown in “ON” position.

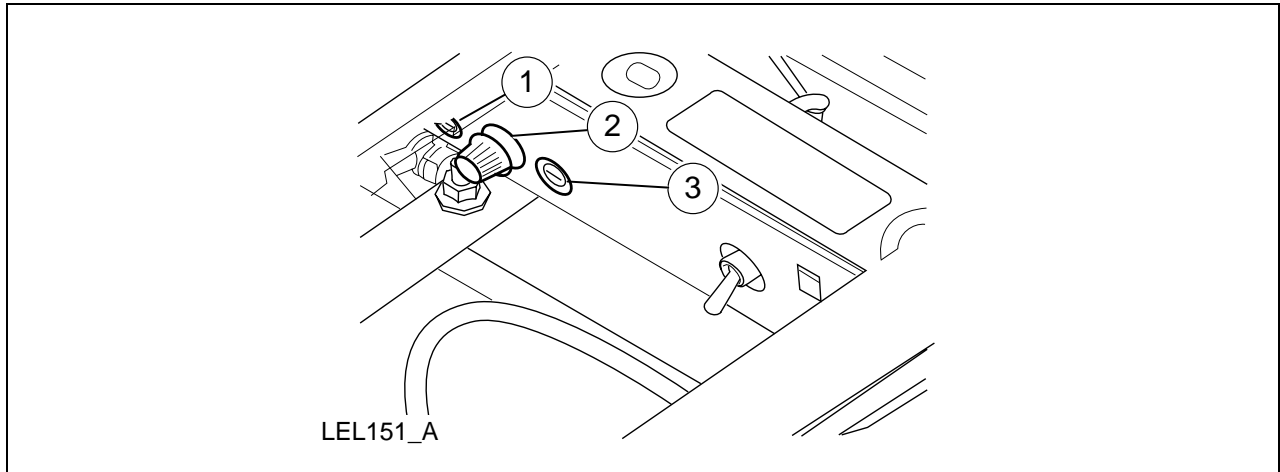

Item	Fuse Amp Rating	Description
1	30A	DC/DC
2	30A	Charger
3	10A	Control (motor controller/gauge)

The optional power point's fuse is located at the front of the vehicle. Remove the hood to access it.

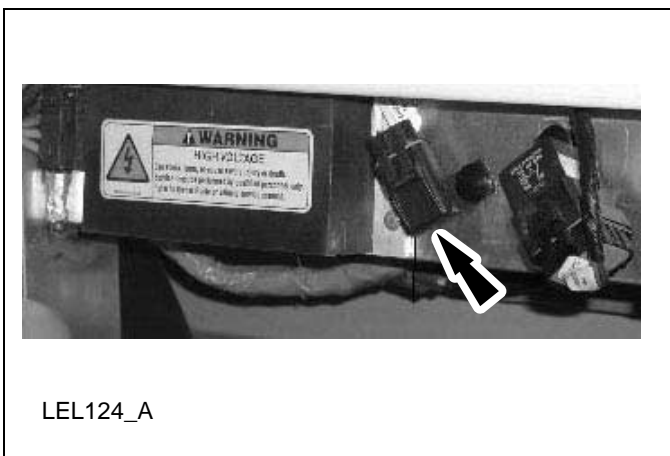

Flasher relay is located on the bottom of the multi-function switch within the steering column shroud.

Warning Labels

The vehicle is equipped with nine different warning labels. These labels are to assist in preventing damage to property or the personal injury or death. The following art illustrates the locations of the warning labels along with their verbiage.

Seat Stanchion Warning Labels

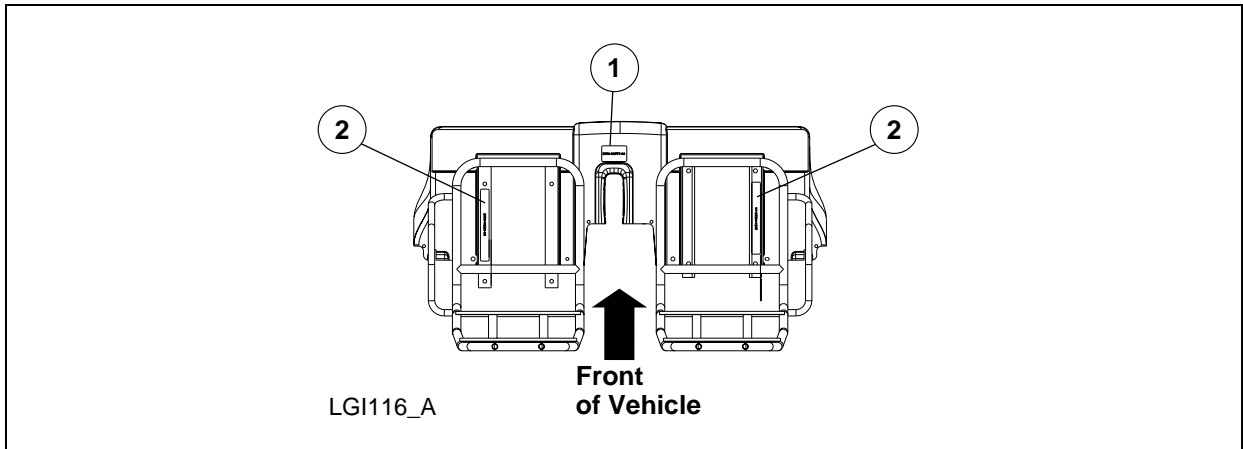

Item	Part Number	Description
1	00014	Parking Brake Warning Label
2	00014	High Voltage Warning Label

Parking Brake Warning Label

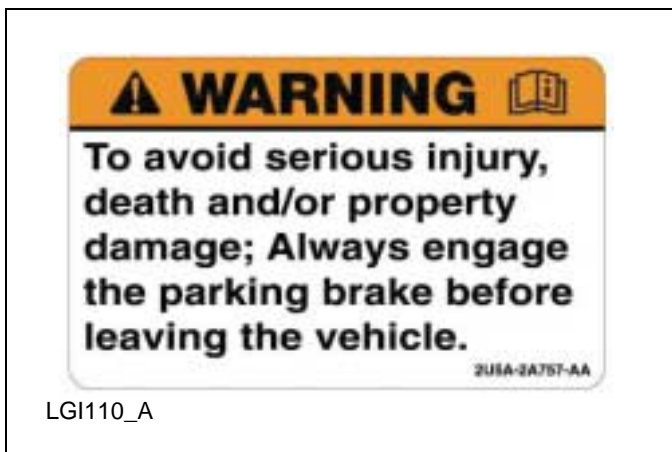

High Voltage Warning Label



Roof Warning Labels

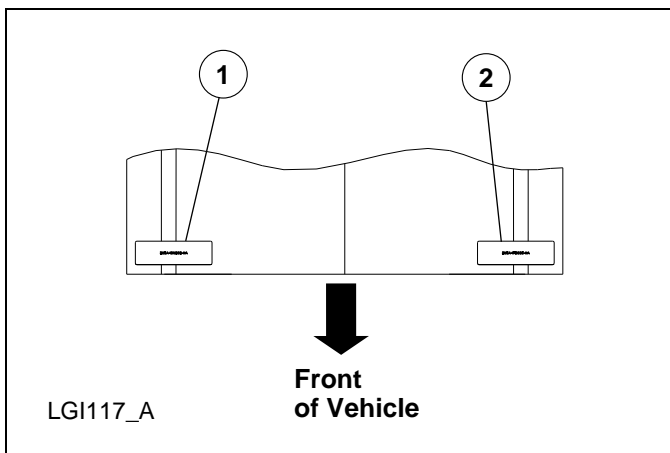

Item	Part Number	Description
1	00014	Slow Moving Vehicle Warning
2	00014	High Voltage Warning Label

Slow Moving Vehicle Warning

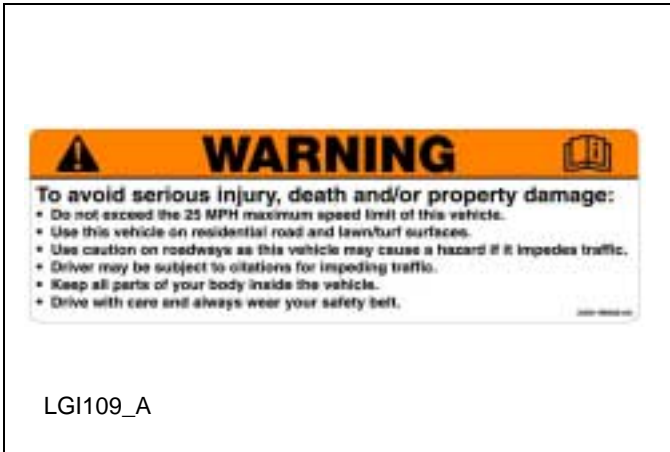

High Voltage Warning Label

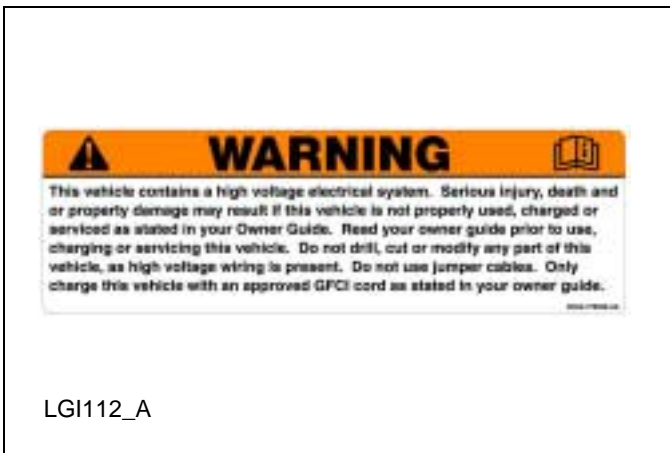

Seat Stanchion Support Warning Label

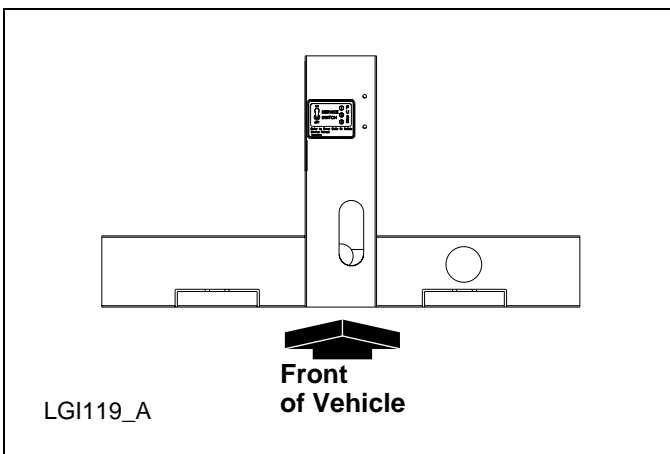

Service Disconnect Switch Label

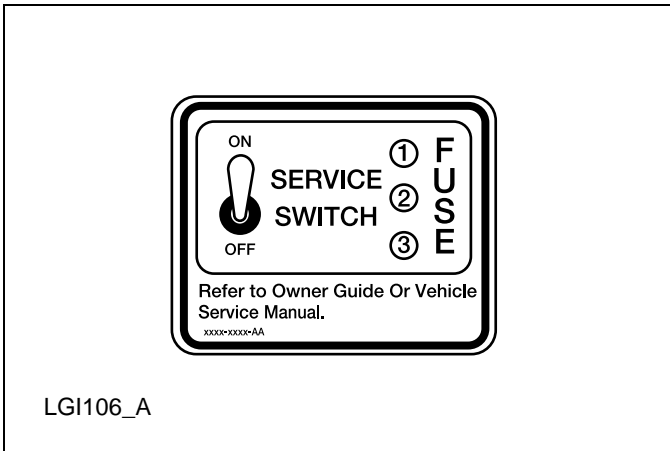

Service Disconnect Switch Label

The service disconnect switch label is located directly under the driver seat on the seat stanchion H-support.

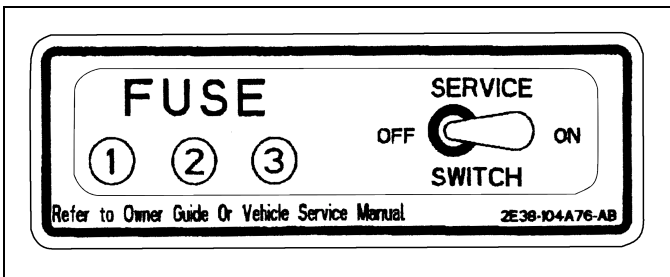

Instrument Panel Charge Warning Label

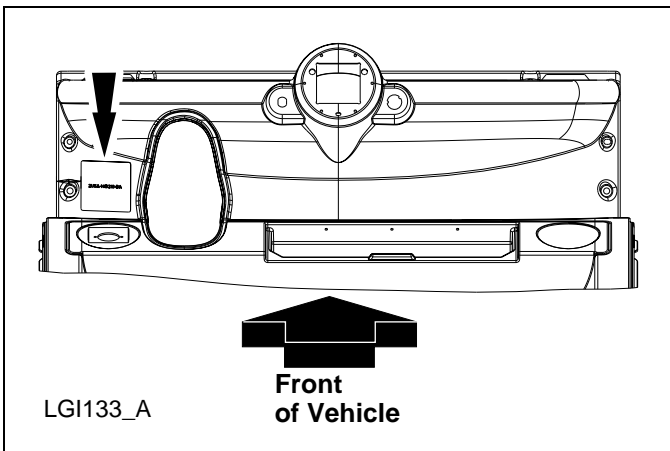

Charge Warning Label

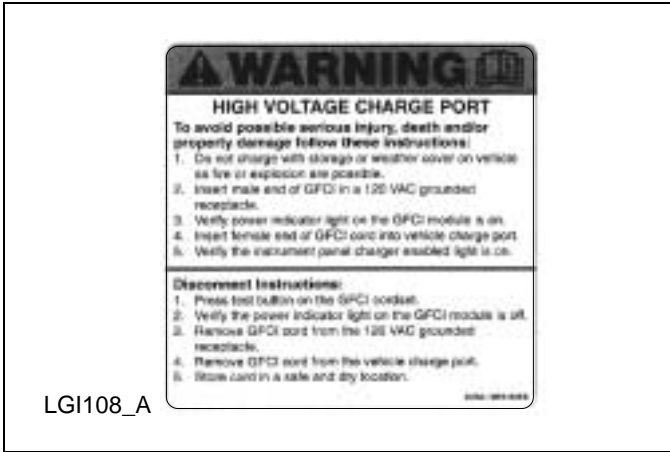

Harness Routing

Low Voltage Wiring Harness

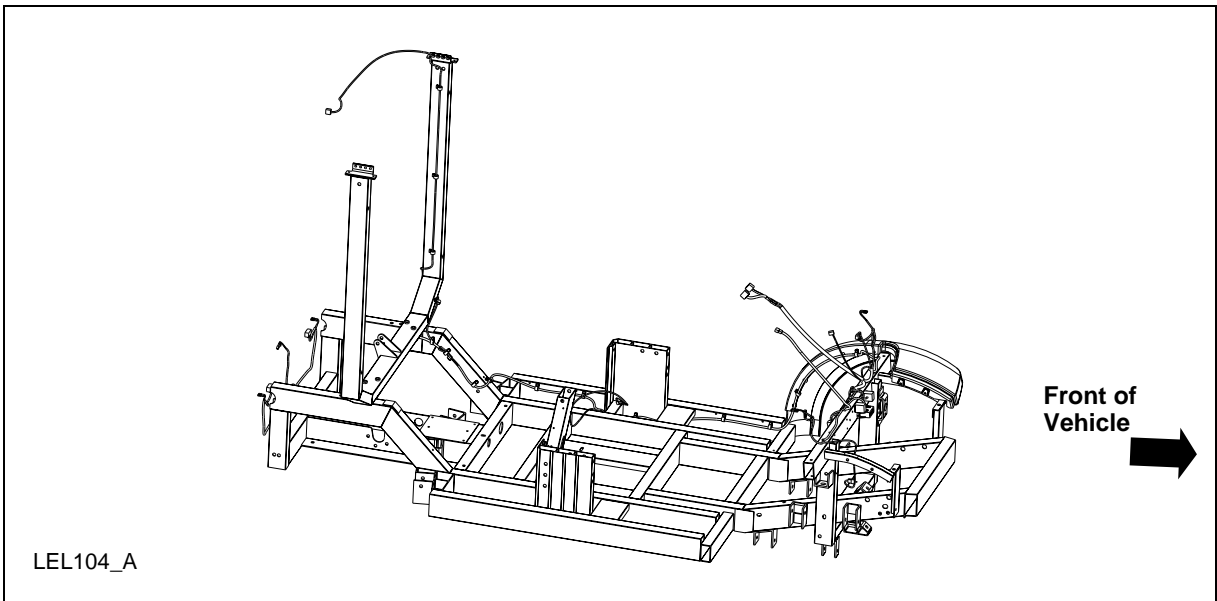

High Voltage Wiring Harnesses

The service disconnect switch location was modified mid year. Refer to the following.

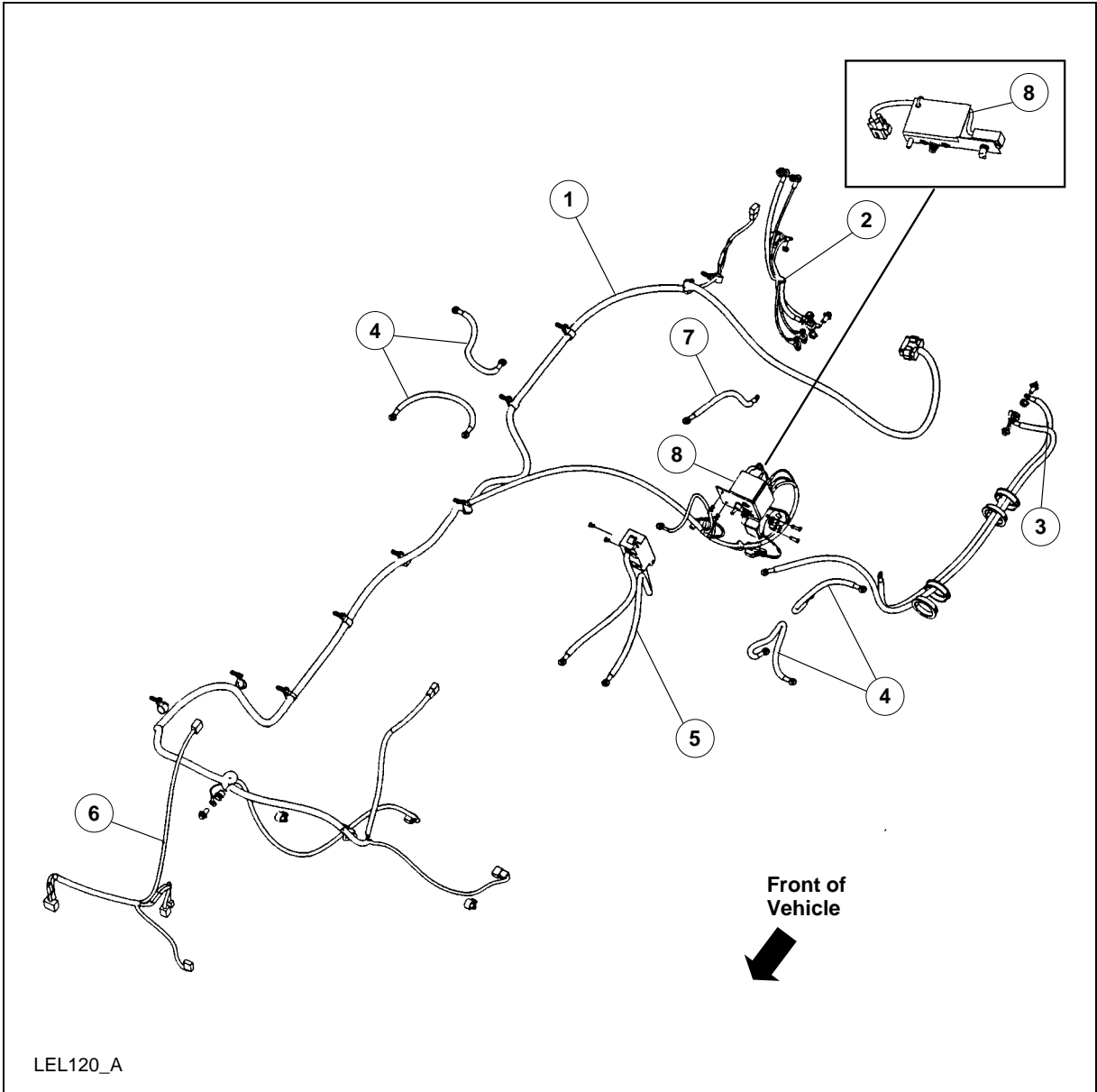

LEL120_A

Item	Part Number	Description
1	14401	Low current high voltage wiring harness
2	14401	Motor controller harness
3	14401	High current high voltage wiring harness
4	14401	Battery interconnect harnesses

Item	Part Number	Description
5	14401	Mega-fuse and wiring harness assembly
6	14401	Power point wiring – Optional
7	14401	72V harness
8	--	Service disconnect switch

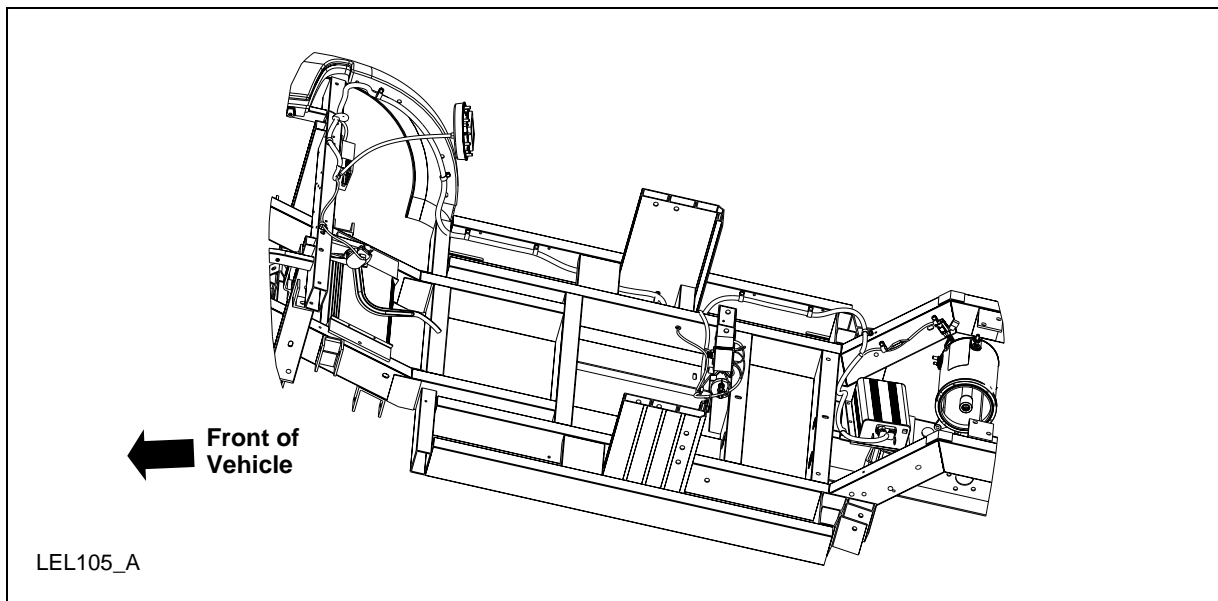

Battery Charging

Battery charging uses 120 volt AC 15A service. The GFCI (ground fault circuit interrupt) charge cord supplied with the vehicle plugs directly into the charge inlet located to the left of the steering column on the front kick-up. Approximately 8-10 hours are needed to replenish a 20% (one bar showing) charged battery pack. Charge the vehicle whenever the state of charge is less than 80% (four bars showing), to maximize the travel range and prolong the battery life.

The battery charger receives 120 volt AC power from an external standard grounded 3-prong 15A outlet and converts it to DC energy. The battery charger only operates when a GFCI charger cord is plugged into your vehicle. If the battery charger detects AC current (from the GFCI charger cord), the vehicle cannot be started or driven.

WARNING!

THERE ARE GASES AROUND THE BATTERIES THAT CAN EXPLODE IF EXPOSED TO FLAMES, SPARKS, OR LIT CIGARETTES. THE AMOUNT OF GAS IS

INCREASED DURING BATTERY CHARGING. AN EXPLOSION COULD RESULT IN PERSONAL INJURY OR VEHICLE DAMAGE.

WARNING!

BATTERIES CONTAIN SULFURIC ACID, WHICH CAN BURN SKIN, EYES, AND CLOTHING, IF CONTACTED.

WARNING!

DO NOT CHARGE THE BATTERIES WITH THE WEATHER ENCLOSURE CLOSED OR THE VEHICLE COVER IN PLACE. A BUILD UP OF HYDROGEN GAS CAN RESULT WHICH CAN EXPLODE. THE CHARGING AREA SHOULD BE WELL VENTILATED.

CAUTION:

If the vehicle is allowed to sit in conditions of -6°C (20°F) or less with a state of charge of 20% (one bar showing on gauge) or less, the batteries could freeze. Allowing the batteries to freeze may cause permanent damage to the batteries and permanently reduce their capacity. In cold conditions, place the vehicle in an area greater than 0°C (32°F) and allow it to warm up before charging. Never charge the vehicle if the batteries may be frozen. Allow the batteries to warm above 0°C (32°F) first, then charge.

CAUTION:

Do not park and leave the vehicle with discharged batteries. The batteries could discharge to the point where damage could occur and the battery charger will not charge.

CAUTION:

If the battery pack is fully charged, the Regenerative Braking System (RBS) will not be enabled because the battery pack cannot accept the additional current. The contactor is designed to open if the battery pack voltage exceeds 80V. Avoid driving situations where you will be driving down steep grades with a fully charged battery pack or the drive system and RBS will shut down. The standard braking system is not affected but speeds may exceed 25 mph (40 km/h). If this should occur, apply brakes to reduce and maintain speeds below 25 mph (40 km/h).

Diagnosis and Testing

Diagnostic Trouble Code Information

Description and Operation

The instrument cluster gauge has the ability to detect and display diagnostic trouble codes (DTCs). The DTCs are of great value to the service technician in finding and repairing vehicle concerns. The instrument cluster gauge stores the 20 most recent DTCs in memory. A complete list of DTCs is provided below.

When retrieving DTCs, record each of the DTCs displayed. Upon completion of the diagnosis and repair required for each DTC, clear the DTCs from the instrument cluster gauge. Refer to

[Retrieving and Clearing DTCs](#). Once the DTCs are cleared, operate the system and recheck for DTCs to verify the repair.

Retrieving and Clearing DTCs

To retrieve DTCs, set the park brake and perform the following:

1. While pressing the Select/Reset button, place the drive mode selector switch in the Drive position.
2. Release the Select/Reset button within 5 seconds. The battery state of charge indicator and the most recent DTC will be displayed.
3. Press and release the Select/Reset button to scroll through the DTCs. The most recent DTC is displayed first followed by the next most recent DTCs.
4. To clear DTCs, press and hold the Select/Reset button for more than 3 seconds.
5. To exit Retrieving and Clearing DTCs, place the drive mode selector switch in the OFF position and either press the Select/Reset button or wait 10 seconds.

The DTC(s) and the odometer reading at which each DTC was set, along with the service required (wrench) indicator, are the only items displayed when the instrument cluster gauge is in Retrieving and Clearing DTCs mode.

Diagnostic Trouble Code (DTC) Chart

DTC	Description	Reference
05	Accelerator potentiometer switch fails to close.	REFER to Accelerator Potentiometer .
06	Accelerator potentiometer pedal is pressed with no direction signal given to motor controller.	REFER to Accelerator Potentiometer .
08	Accelerator potentiometer input voltage to the motor controller is greater than 1.25V on power-up after initial drive mode selector switch closure.	REFER to Accelerator Potentiometer .
09	Both the forward and reverse direction switches are closed at the same time.	REFER to Instrument Cluster Gauge .
11	Accelerator potentiometer switch closed on power up after initial drive mode selector switch closure.	REFER to Accelerator Potentiometer .

DTC	Description	Reference
15	Battery voltage is less than 68.3 volts at initial drive mode selector switch closure.	REFER to Battery .
16	Battery voltage is greater than 86 volts at initial drive mode selector switch closure.	REFER to Battery .
21	Accelerator voltage is too high.	REFER to Motor and Motor Controller .
23	Motor field current is high on start-up in the reverse direction.	REFER to Motor and Motor Controller .
24	Motor field current is high on start-up in the forward direction.	REFER to Motor and Motor Controller .
27	12V bus is too low.	REFER to Motor and Motor Controller .
41	Open thermal protector (TP) or transistor over-temperature.	REFER to Motor and Motor Controller .
42	Motor armature offset voltage too high.	REFER to Motor and Motor Controller .
43	Motor armature offset voltage too low.	REFER to Motor and Motor Controller .
44	Armature transistor did not turn off properly.	REFER to Motor and Motor Controller .
45	Armature transistor did not turn on properly.	REFER to Motor and Motor Controller .
46	“Look Ahead” test for A2 voltage less than 12% of battery voltage.	REFER to Motor and Motor Controller .
49	Motor field current is too low during the Run mode.	REFER to Motor and Motor Controller .
51	Capacitor voltage is low before the line contactor closes.	REFER to Motor and Motor Controller .
57	Controller “motor current sensor” input too low while running.	REFER to Motor and Motor Controller .

DTC	Description	Reference
66	The field current exceeds the current limit of the field transistor.	REFER to Motor and Motor Controller .
76	Capacitor 1C voltage too high during regenerative braking.	REFER to Motor and Motor Controller .
77	Capacitor 1C voltage too high during motoring.	REFER to Motor and Motor Controller .
90	Motor thermostat is open during control operation.	REFER to Motor and Motor Controller .

Basic Troubleshooting Information

Description and Operation

Basic Troubleshooting Information is a series of troubleshooting flowcharts and pinpoint tests that may be useful in diagnosing certain vehicle or system concerns. To diagnose any of the following symptoms, refer to the corresponding troubleshooting flowchart and follow the diagnostic steps provided.

Troubleshooting Flowcharts

Vehicle No Enable Troubleshooting

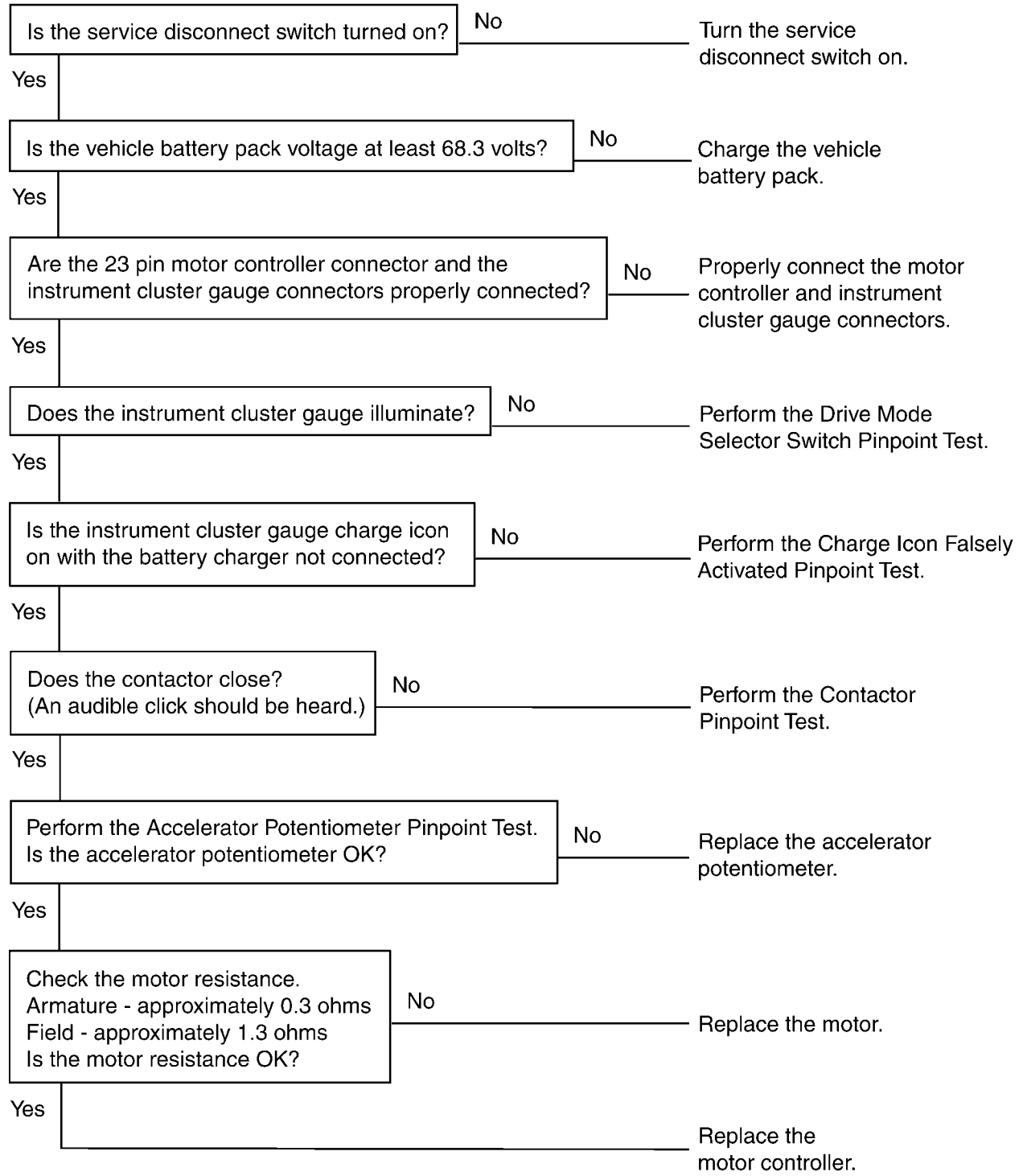

Lack of Speed Troubleshooting

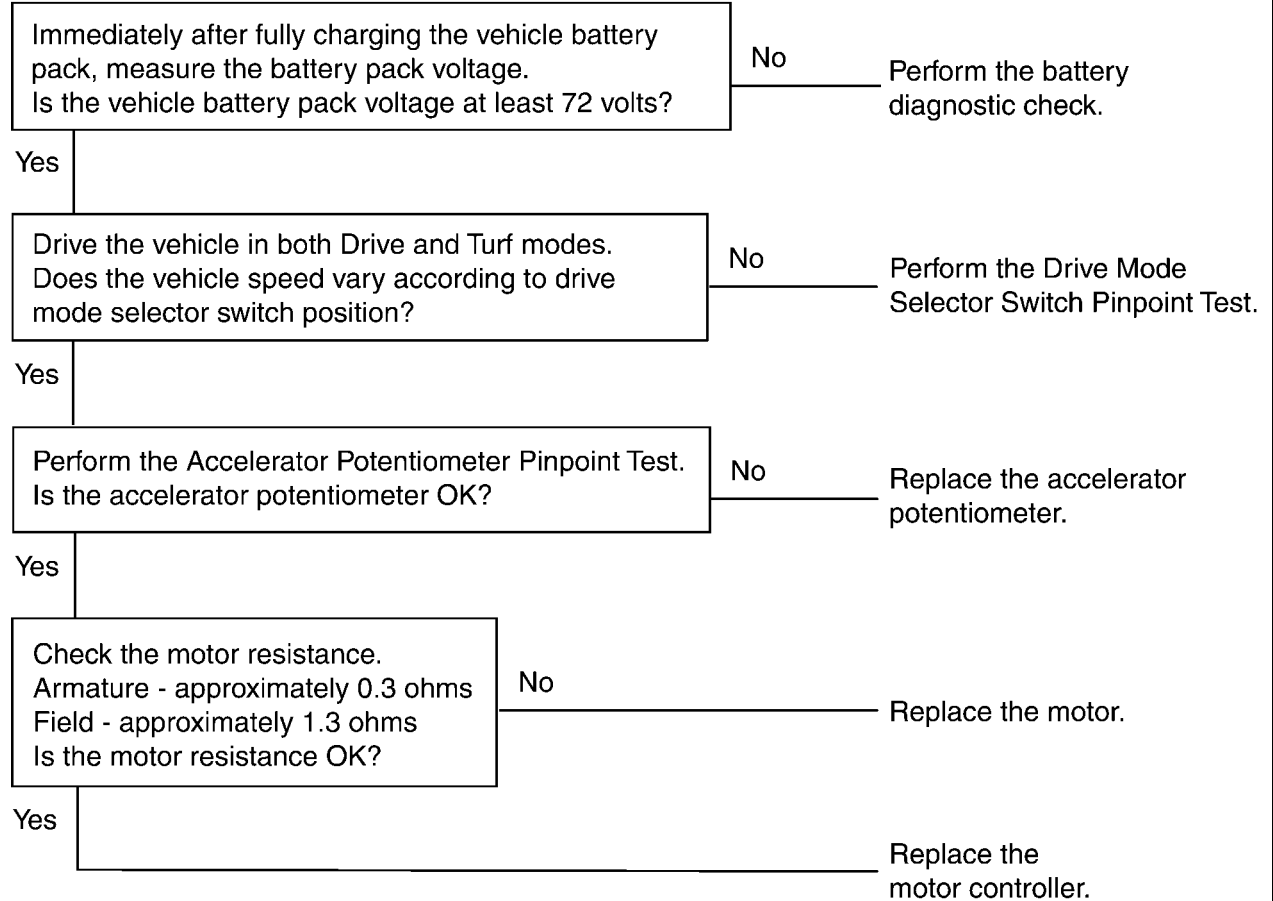

Low Range Troubleshooting

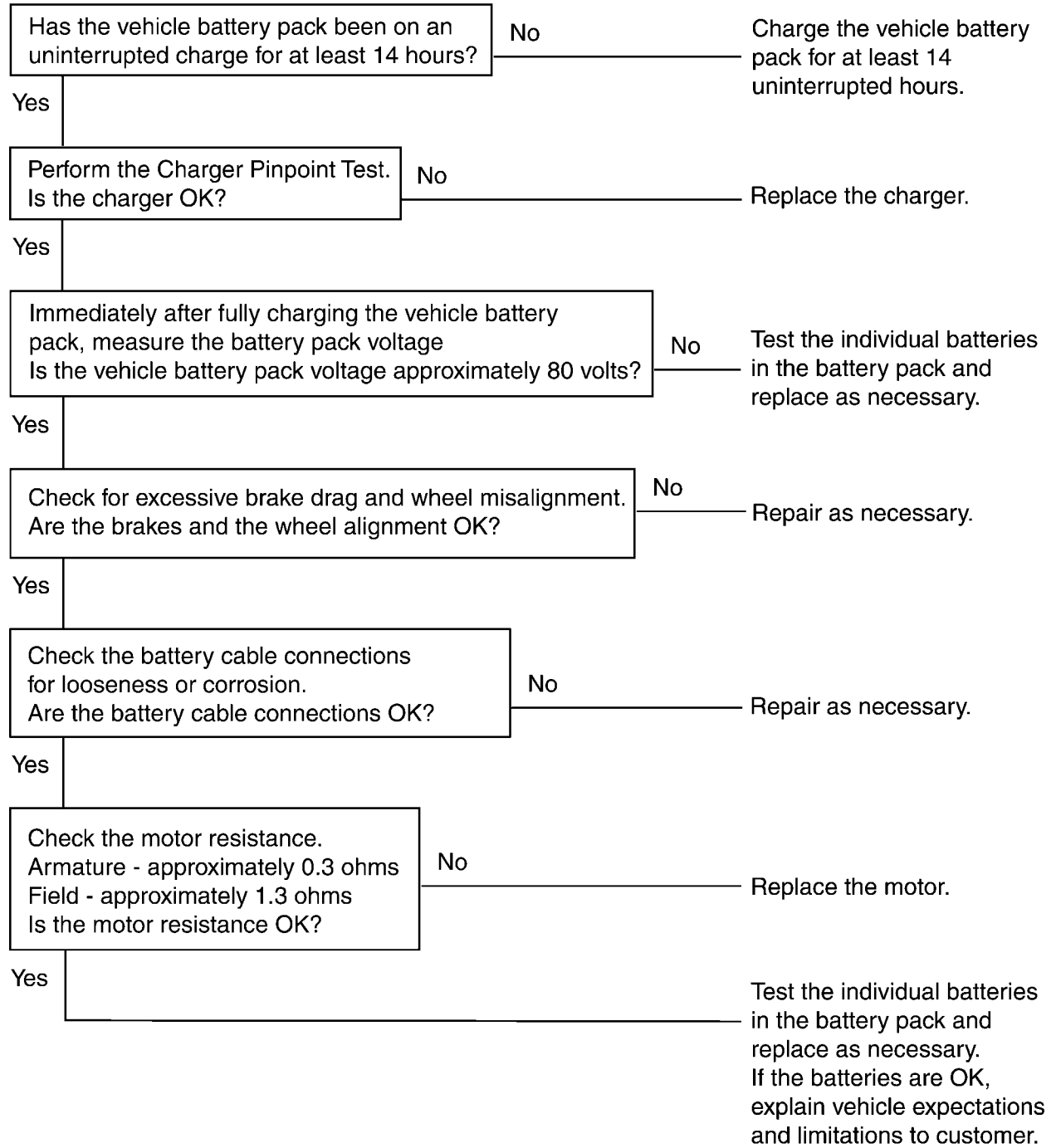

Drive Mode Selector Switch Pinpoint Test

WARNING:

THE BATTERY PACK ASSEMBLY CAN DELIVER IN EXCESS OF 72 VOLTS OF DC POWER. IMPROPER HANDLING OF THE BATTERY PACK CAN RESULT IN INJURY OR FATALITY. ONLY AUTHORIZED PERSONNEL TRAINED TO WORK WITH BATTERY PACK COMPONENTS ARE PERMITTED TO HANDLE THE BATTERIES.

WARNING:

THE BATTERY PACK CONTAINS HIGH-VOLTAGE COMPONENTS AND WIRING. HIGH-VOLTAGE INSULATED SAFETY GLOVES AND FACE SHIELD MUST BE WORN WHEN PERFORMING THE FOLLOWING STEPS. FAILURE TO FOLLOW THIS WARNING MAY RESULT IN SEVERE PERSONAL INJURY OR DEATH.

Step	Action	Connector End View
1.	1. Disconnect the drive mode selector switch harness connector. 2. Connect a DVOM between the drive mode selector switch harness connector terminal 2 and the vehicle chassis. Does the DVOM display approximately 12 volts? Yes – GO to Step 2. No – INSTALL a new instrument cluster gauge. REFER to Instrument Cluster Gauge in this section. OPERATE the system to verify the repair.	Drive Mode Selector Switch – J5
2.	Connect a fused jumper wire between the drive mode selector switch harness connector J5 terminal 1 and terminal 2 (on the component side). Does the instrument cluster gauge backlighting illuminate? Yes – GO to Step 3. No – INSTALL a new instrument cluster gauge. REFER to Instrument Cluster Gauge in this section. OPERATE the system to verify the repair.	Drive Mode Selector Switch – J5
3.	Connect a fused jumper wire between the drive mode selector switch harness connector J5 terminal 1 and terminal 3 (on the component side). Does the instrument cluster gauge backlighting illuminate?	Drive Mode Selector Switch – J5

Step	Action	Connector End View
	<p>Yes – GO to Step 4.</p> <p>No – INSTALL a new instrument cluster gauge. REFER to Instrument Cluster Gauge in this section. OPERATE the system to verify the repair.</p>	
4.	<p>Connect a fused jumper wire between the drive mode selector switch harness connector J5 terminal 1 and terminal 4 (on the component side).</p> <p>Does the instrument cluster gauge backlighting illuminate?</p> <p>Yes – INSTALL a new drive mode selector switch. REFER to Drive Mode Selector Switch in this section. OPERATE the system to verify the repair.</p> <p>No – INSTALL a new instrument cluster gauge. REFER to Instrument Cluster Gauge in this section. OPERATE the system to verify the repair.</p>	Drive Mode Selector Switch – J5

Charge Icon Falsely Activated Pinpoint Test

Step	Action	Connector End View
1.	<p>1. Make sure the GFCI charger cord is not connected to the vehicle.</p> <p>2. Check the 30A charger fuse.</p> <p>Is the fuse OK?</p> <p>Yes – GO to Step 2.</p> <p>No – INSTALL a new fuse. OPERATE the system to verify the repair.</p>	
2.	<p>Check the fuse cap.</p> <p>Is the fuse cap OK?</p> <p>Yes – GO to Step 3.</p> <p>No – INSTALL a new fuse cap. OPERATE the system to verify the repair.</p>	
3.	<p>Check charger harness connector and instrument cluster gauge harness connectors for partially seated terminals, connectors</p>	

Step	Action	Connector End View
	<p>not mating properly and for dirt, moisture or corrosion.</p> <p>Are the charger and instrument cluster gauge harness connectors OK?</p> <p>Yes – INSTALL a new charger. REFER to Charger in this section. OPERATE the system to verify the repair.</p> <p>No – REPAIR the harness connector(s) as necessary. OPERATE the system to verify the repair.</p>	

Contactor Pinpoint Test

Step	Action	Connector End View
1.	<p>Check the battery pack voltage</p> <p>Is the battery pack voltage at least 68.3 volts?</p> <p>Yes – GO to Step 2.</p> <p>No – CHARGE the vehicle battery pack and retest. If the voltage is still below 68.3 volts, REFER to Battery in this section for further diagnosis.</p>	
2.	<ol style="list-style-type: none"> 1. Turn the drive mode selector switch to the Reverse, Turf or Drive position. 2. Check the instrument cluster gauge. <p>Is the instrument cluster gauge charge icon activated?</p> <p>Yes – REFER to the Charge Icon Falsely Activated Pinpoint Test.</p> <p>No – GO to Step 3.</p>	
3.	<ol style="list-style-type: none"> 1. Turn the drive mode selector switch to the off position. 2. Disconnect the motor controller harness connector. 3. Turn the drive mode selector switch to the Reverse, Turf or Drive position. 4. Connect a DVOM between motor controller harness 	Motor Controller

Step	Action	Connector End View
	connector terminal 11 and the vehicle chassis. Does the DVOM display approximately 72 volts? Yes – GO to Step 4. No – GO to Step 6.	
4.	Connect a fused jumper wire between motor controller connector terminal 11 and the vehicle chassis. Does the contactor close? Yes – GO to Step 5. No – INSTALL a new contactor. OPERATE the system to verify the repair.	Motor Controller
5.	Connect a DVOM between motor controller connector terminal 1 and the vehicle chassis. Does the DVOM display approximately 72 volts? Yes – GO to Step 7. No – GO to Step 8.	Motor Controller
6.	Connect a DVOM between contactor terminal 2 and the vehicle chassis. Does the DVOM display approximately 72 volts? Yes – INSTALL a new contactor. OPERATE the system to verify the repair. No – REPAIR circuit 41 (OR/VT). OPERATE the system to verify the repair.	Contactor
7.	Connect a DVOM between motor controller connector terminal 2 and the vehicle chassis. Does the DVOM display approximately 72 volts? Yes – INSTALL a new motor controller. REFER to Motor Controller in the Powertrain section. OPERATE the system to verify the repair.	Motor Controller

Step	Action	Connector End View
	No – GO to Step 9.	
8.	<p>1. Disconnect the instrument cluster gauge connector J7A.</p> <p>2. Connect a DVOM between the contactor connector terminal 2 and the instrument cluster gauge connector J7A terminal 7.</p> <p>Does continuity exist?</p> <p>Yes – INSTALL a new instrument cluster gauge. REFER to Instrument Cluster Gauge in this section. OPERATE the system to verify the repair.</p> <p>No – REPAIR circuit 41 (OG/VT) between the contactor and the instrument cluster gauge. OPERATE the system to verify the repair.</p>	<p>Instrument Cluster Gauge—J7A</p> <p>Contactor</p>

Accelerator Potentiometer Pinpoint Test

WARNING:

THE BATTERY PACK ASSEMBLY CAN DELIVER IN EXCESS OF 72 VOLTS OF DC POWER. IMPROPER HANDLING OF THE BATTERY PACK CAN RESULT IN INJURY OR FATALITY. ONLY AUTHORIZED PERSONNEL TRAINED TO WORK WITH BATTERY PACK COMPONENTS ARE PERMITTED TO HANDLE THE BATTERIES.

WARNING:

THE BATTERY PACK CONTAINS HIGH-VOLTAGE COMPONENTS AND WIRING. HIGH-VOLTAGE INSULATED SAFETY GLOVES AND FACE SHIELD MUST BE WORN WHEN PERFORMING THE FOLLOWING STEPS. FAILURE TO FOLLOW THIS WARNING MAY RESULT IN SEVERE PERSONAL INJURY OR DEATH.

Step	Action	Connector End View
1.	<p>1. Place the drive mode selector switch in the OFF position.</p> <p>2. Disconnect the motor controller harness connector.</p> <p>3. Place the drive mode selector switch in the Reverse, Turf or Drive position.</p>	<p>Motor Controller Accelerator Potentiometer</p>

Step	Action	Connector End View
	<p>4. Connect a DVOM between the motor controller harness connector terminal 3 and the vehicle chassis.</p> <p>Does the DVOM display greater than 10 volts with the accelerator pedal pressed and approximately 0 volts with the accelerator pedal released?</p> <p>Yes - GO to Step 2.</p> <p>No – INSTALL a new accelerator potentiometer. REFER to Accelerator Potentiometer in the Powertrain section. OPERATE the system to verify the repair.</p>	
2.	<ol style="list-style-type: none"> 1. Disconnect the motor controller harness connector and the accelerator potentiometer harness connector. 2. Connect a DVOM between the motor controller harness connector terminal 7 and the accelerator potentiometer harness connector terminal A. 3. Connect a DVOM between the motor controller harness connector terminal 8 and the accelerator potentiometer harness connector terminal E. 4. Connect a DVOM between the motor controller harness connector terminal 9 and the accelerator potentiometer harness connector terminal G. 5. Connect a DVOM between the motor controller harness connector terminal 13 and the accelerator potentiometer harness connector terminal J <p>Does continuity exist?</p> <p>Yes – GO to Step 3.</p> <p>No – INSTALL a new 72 volt harness. REFER to Wiring Harnesses in this section. OPERATE the system to verify the repair.</p>	<p>Motor Controller Accelerator Potentiometer</p>
3.	<ol style="list-style-type: none"> 1. Reconnect the accelerator potentiometer harness connector. 2. Connect a DVOM between the motor controller harness connector terminal 7 and terminal 8. <p>Does the DVOM display between 1.9k and 3.9k ohms with the accelerator potentiometer pedal raised and between 3.7k and 5.7k ohms with the accelerator potentiometer pedal pressed?</p> <p>Yes – GO to Step 4.</p> <p>No – INSTALL a new accelerator potentiometer. REFER</p>	<p>Motor Controller Accelerator Potentiometer</p>

Step	Action	Connector End View
	to Accelerator Potentiometer in the Powertrain section. OPERATE the system to verify the repair.	
4.	<p>Connect a DVOM between the motor controller harness connector terminal 8 and terminal 13.</p> <p>Does the DVOM display between 3.7k and 5.7k ohms with the accelerator potentiometer pedal raised and between 1.9k and 3.9k ohms with the accelerator potentiometer pedal pressed?</p> <p>Yes – GO to Step 5.</p> <p>No – INSTALL a new accelerator potentiometer. REFER to Accelerator Potentiometer in the Powertrain section. OPERATE the system to verify the repair.</p>	Motor Controller
5.	<p>Connect a DVOM between the motor controller harness connector terminal 8 and terminal 9.</p> <p>Does the DVOM display less than 5k ohms?</p> <p>Yes – INSTALL a new motor controller. REFER to Motor Controller in the Powertrain section. OPERATE the system to verify the repair.</p> <p>No – INSTALL a new accelerator potentiometer. REFER to Accelerator Potentiometer in the Powertrain section. OPERATE the system to verify the repair.</p>	Motor Controller

Charger Pinpoint Test

WARNING:

THE BATTERY PACK ASSEMBLY CAN DELIVER IN EXCESS OF 72 VOLTS OF DC POWER. IMPROPER HANDLING OF THE BATTERY PACK CAN RESULT IN INJURY OR FATALITY. ONLY AUTHORIZED PERSONNEL TRAINED TO WORK WITH BATTERY PACK COMPONENTS ARE PERMITTED TO HANDLE THE BATTERIES.

WARNING:

THE BATTERY PACK CONTAINS HIGH-VOLTAGE COMPONENTS AND WIRING. HIGH-VOLTAGE INSULATED SAFETY GLOVES AND FACE SHIELD MUST BE WORN WHEN PERFORMING THE FOLLOWING STEPS. FAILURE TO FOLLOW THIS WARNING MAY RESULT IN SEVERE PERSONAL INJURY OR DEATH.

Step	Action	Connector End View
1.	1. Disconnect the charger harness connector. 2. Connect a DVOM between the charger harness connector terminal 1 and terminal 2. Does the DVOM display approximately 72 volts? Yes – GO to Step 2. No – GO to Step 4.	Charger
2.	1. Reconnect the charger connector. 2. Connect the GFCI charger cord to the charger. 3. Verify charger operation by listening for a buzz noise and feeling for a slight vibration from the charger. Does the charger operate? Yes – GO to Step 3. No – GO to Step 7.	
3.	With the GFCI cord connected to the charger, connect a DVOM between the battery pack positive and battery pack negative. Does the voltage increase after two minutes? Yes – The system is OK. No – TEST the batteries. REFER to Battery Test in this section. If all batteries are OK, INSTALL a new charger. REFER to Charger in this section. OPERATE the system to verify the repair.	
4.	Connect a DVOM between the battery pack positive and battery pack negative. Does the DVOM display approximately 72 volts? Yes – GO to Step 5. No – TEST the batteries. REFER to Battery Test in this section.	
5.	Connect a DVOM between the charger harness connector terminal 2 and the battery pack negative. Does continuity exist? Yes – GO to Step 6.	Charger

Step	Action	Connector End View
	<p>No – INSTALL a new 72 volt harness. REFER to Wiring Harnesses in this section. OPERATE the system to verify the repair.</p>	
6.	<p>1. Perform the Power Shutdown Procedure. Refer to Power Shutdown Procedure in this section.</p> <p>2. Connect a DVOM between the charger harness connector terminal 1 and the battery pack positive.</p> <p>Does continuity exist?</p> <p>Yes – The system is OK.</p> <p>No – INSTALL a new 72 volt harness. REFER to Wiring Harnesses in this section. OPERATE the system to verify the repair.</p>	Charger
7.	<p>1. Connect a known good GFCI cord to the charger.</p> <p>2. Verify charger operation by listening for a buzz noise and feeling for a slight vibration from the charger.</p> <p>Does the charger operate?</p> <p>Yes – INSTALL a new GFCI cord. OPERATE the system to verify the repair.</p> <p>No – INSTALL a new charger. REFER to Charger in this section. OPERATE the system to verify the repair.</p>	

Power Distribution

Circuit Schematic

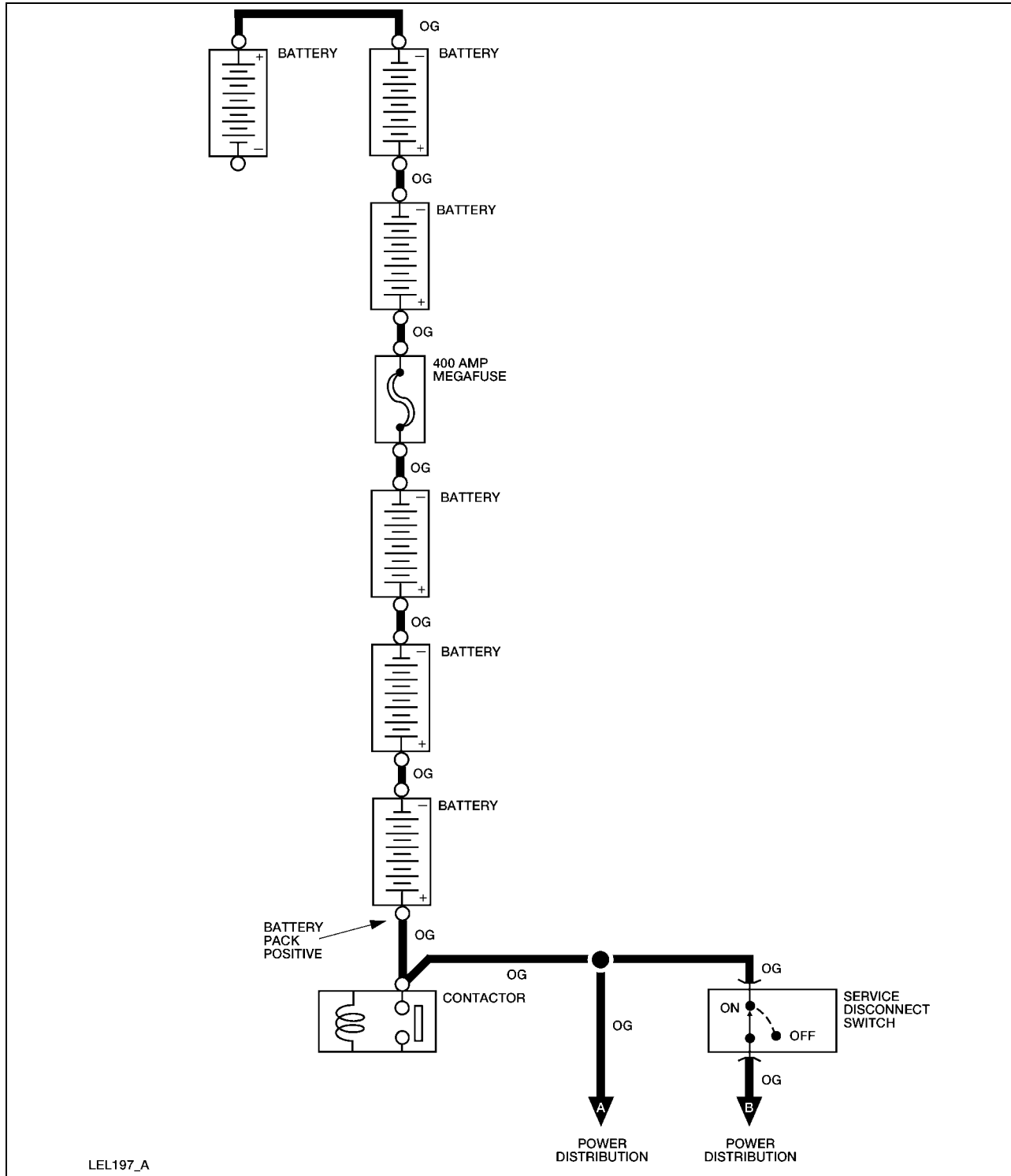

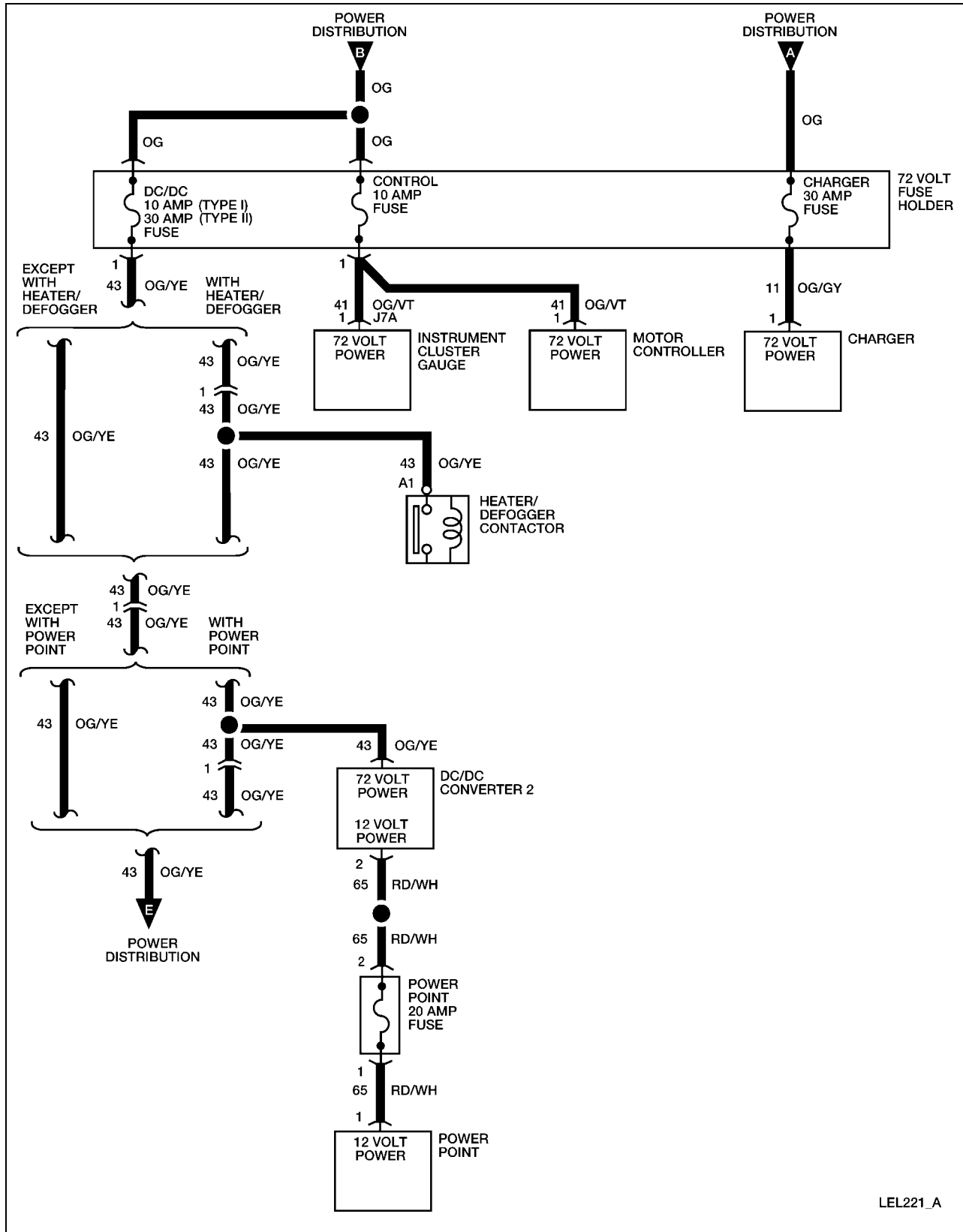

LEL221_A

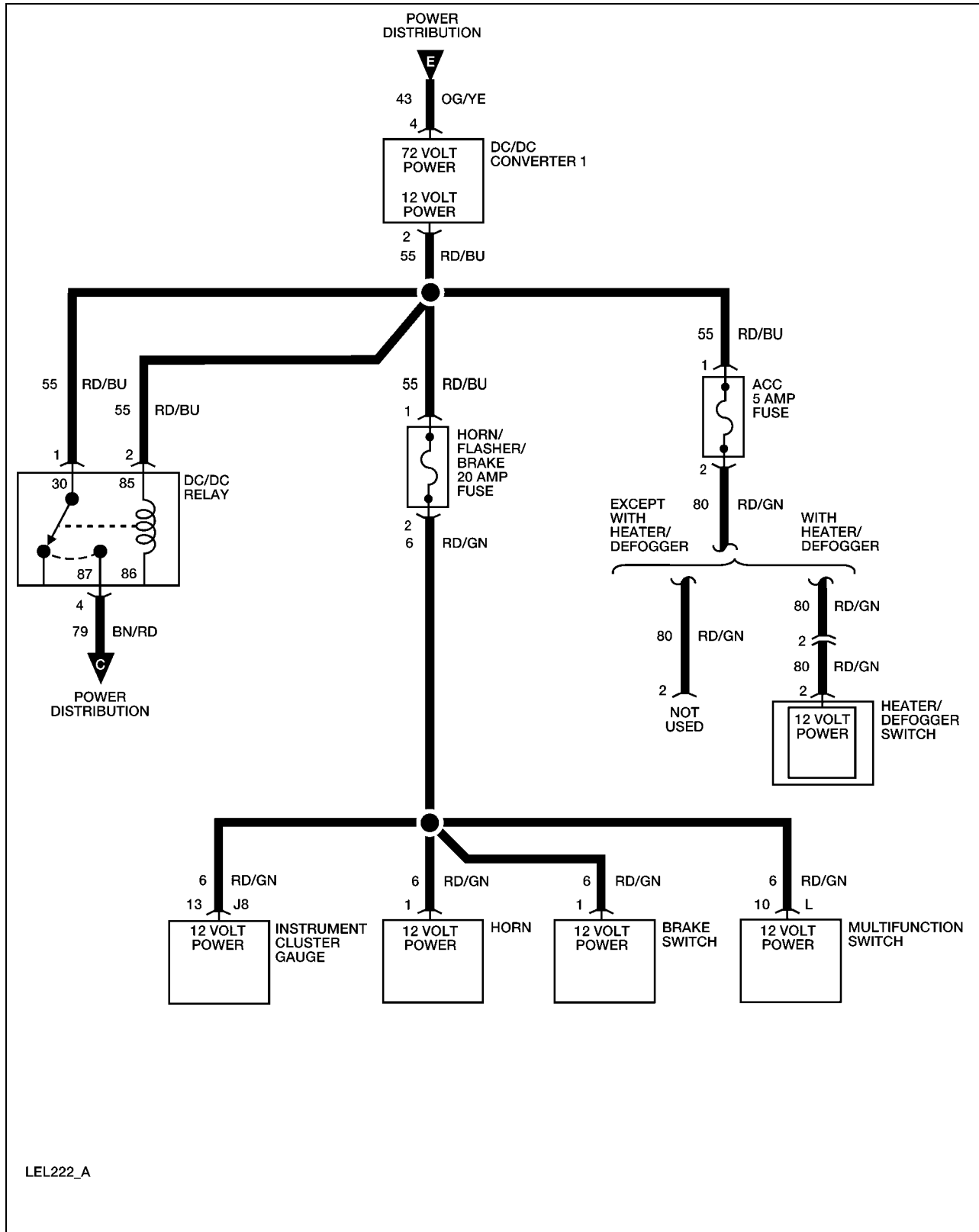

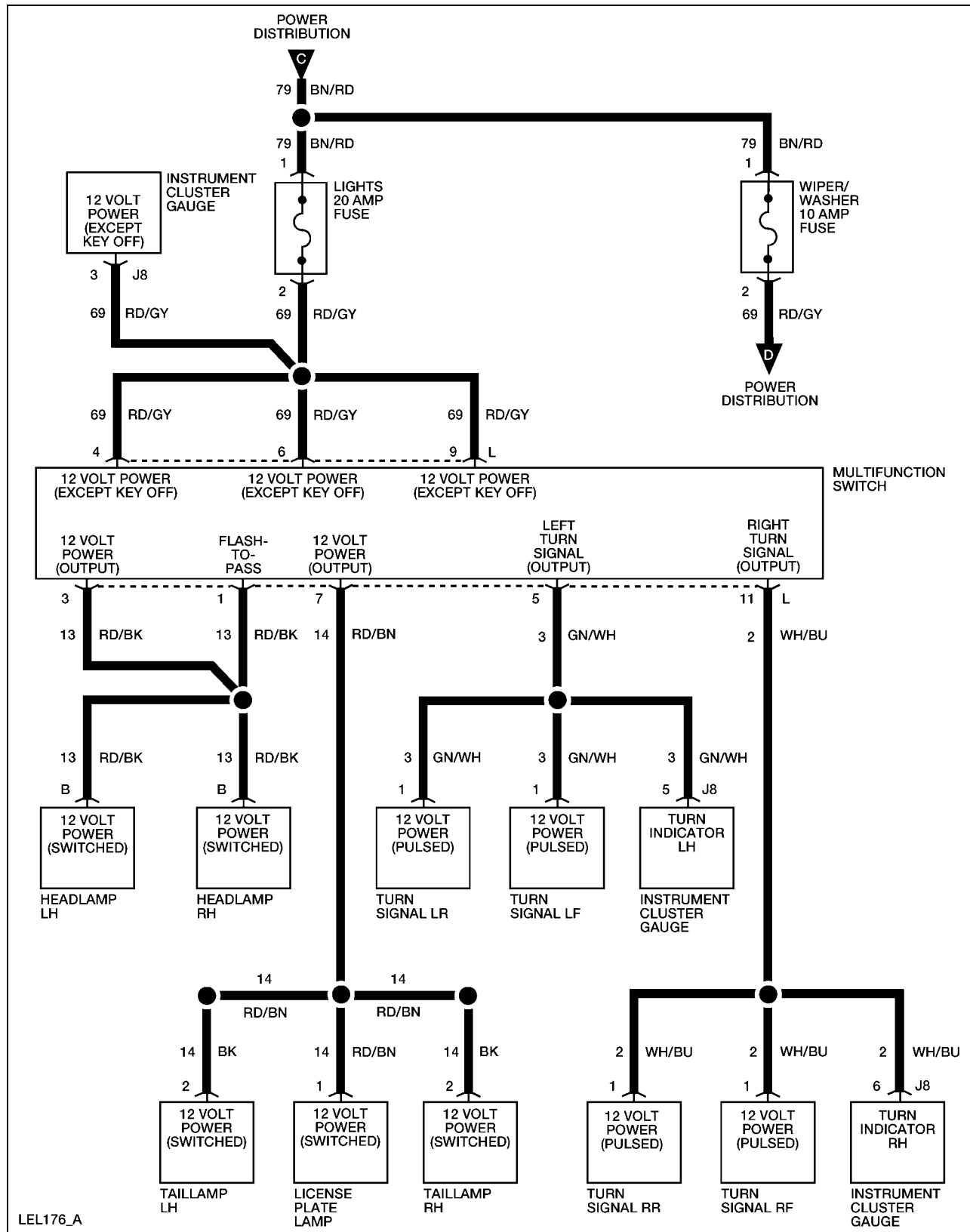

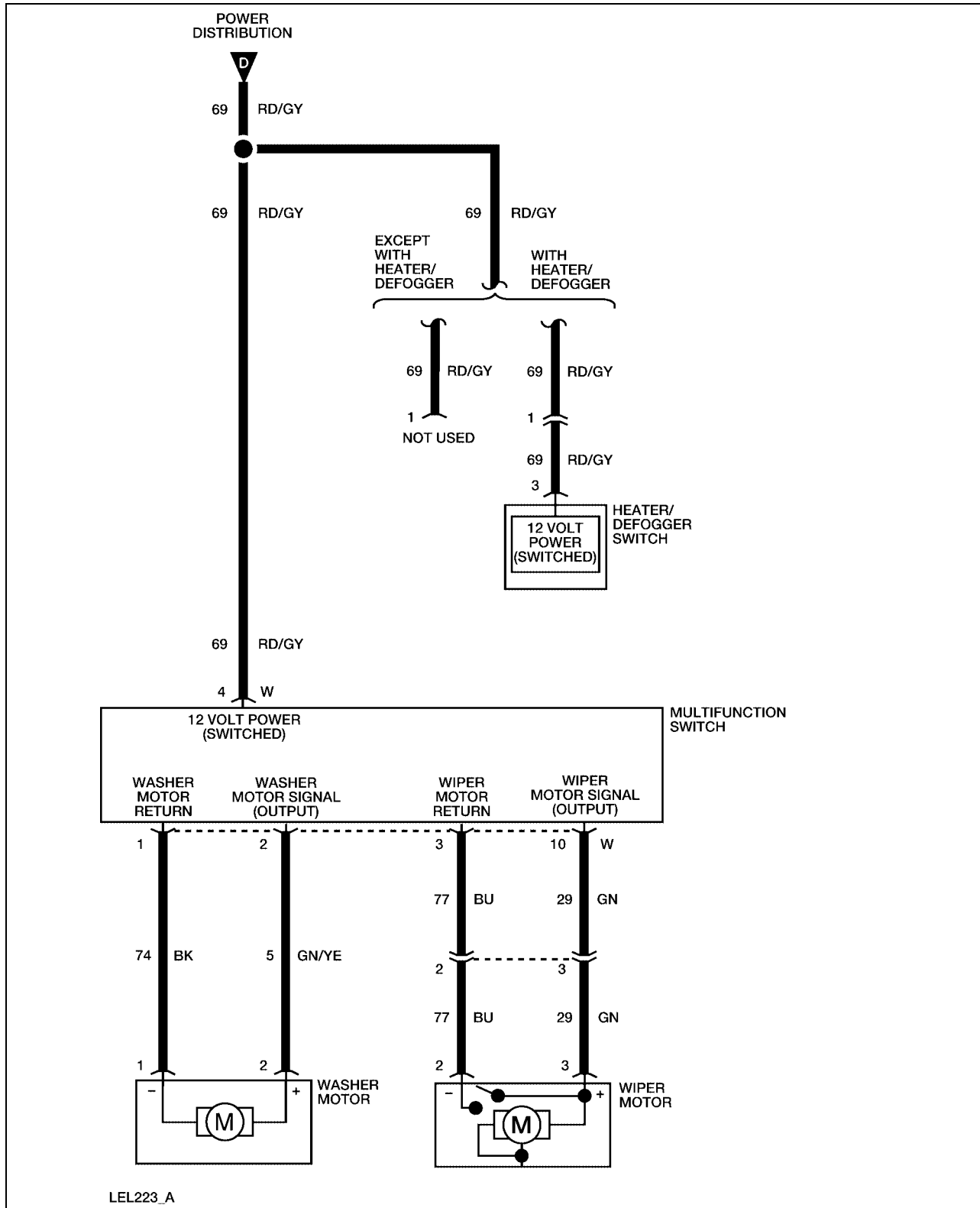

Ground Distribution Circuit Schematic – With Heater/Defogger

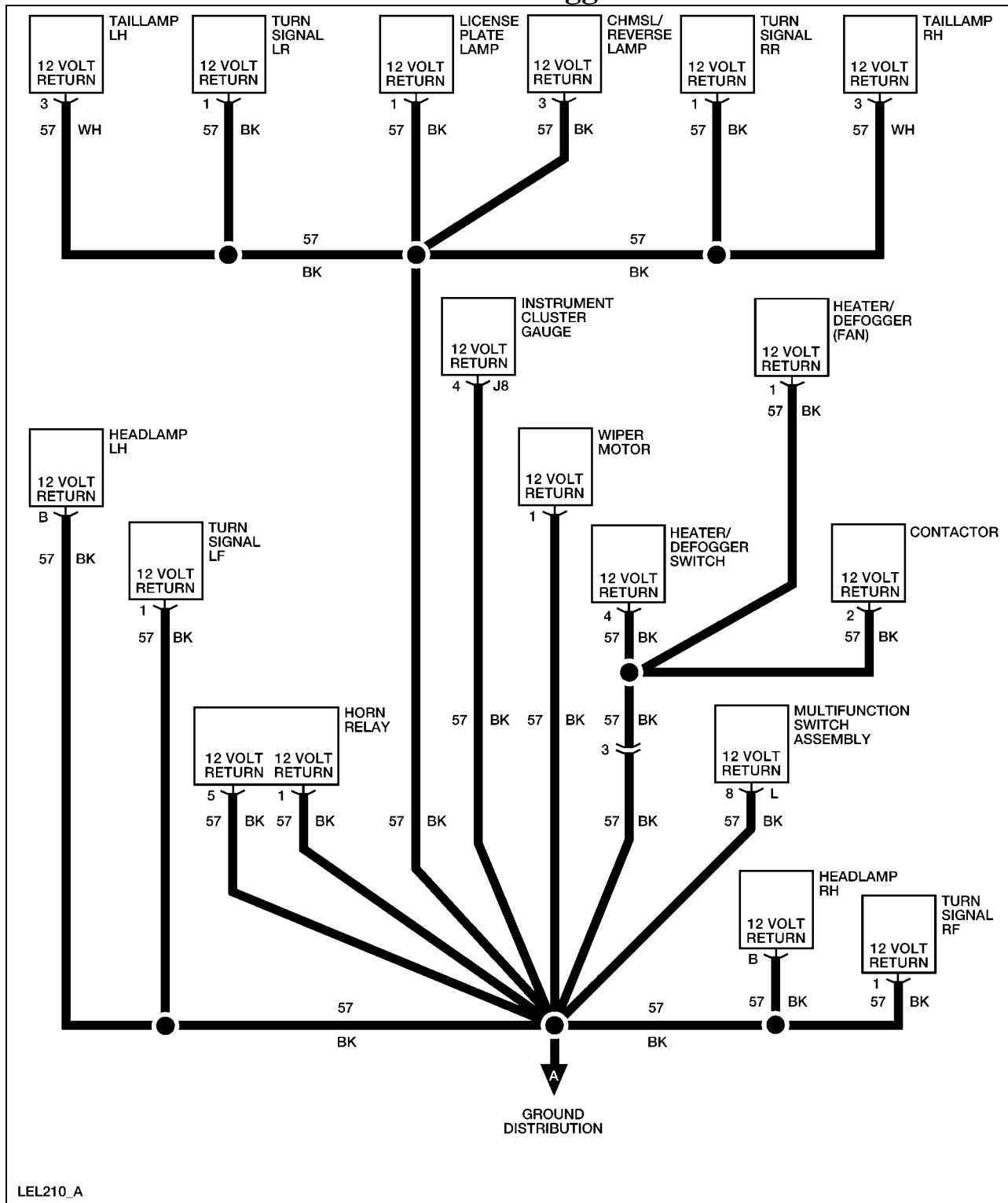

LEL210_A

Without Heater/Defogger

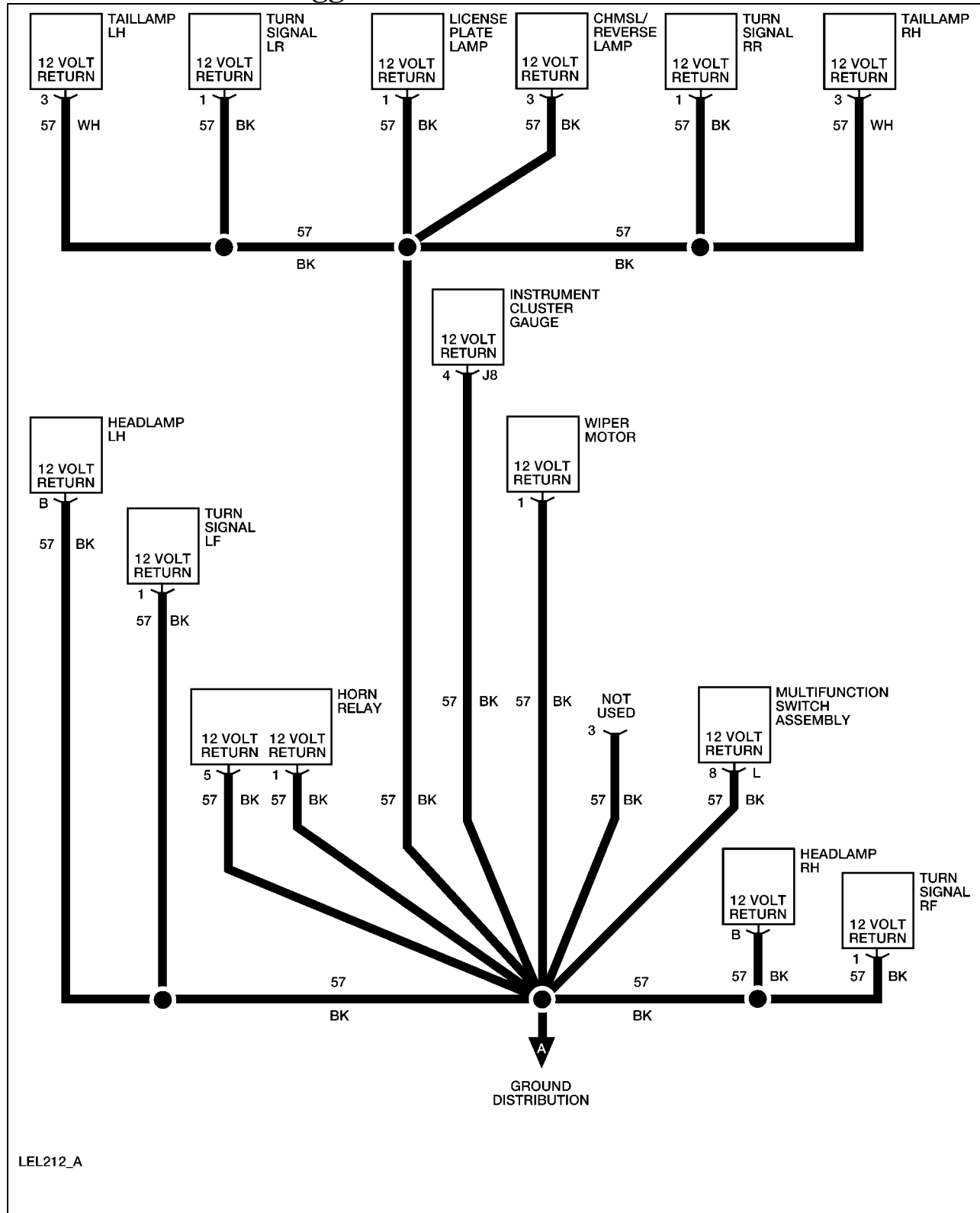

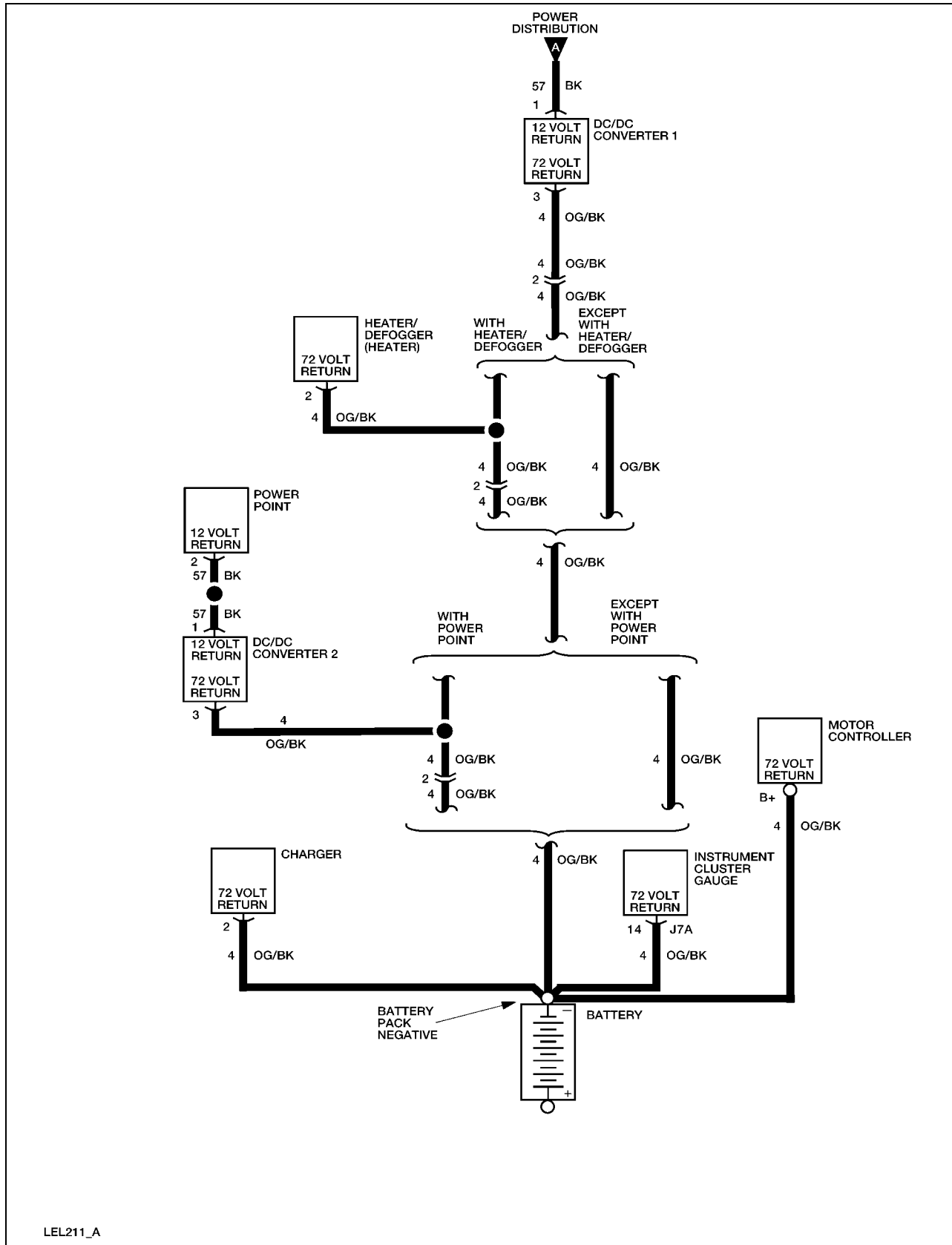

LEL211_A

Electrical Leakage Detection

Circuit Description and Operation

The electrical leakage detection circuit measures current flow from the battery pack to the vehicle frame. The battery pack is electrically isolated from the vehicle frame. There are four system components that ground to the frame: headlamps, chassis connector, wiper motor and the park brake switch. The chassis connector circuit is between the instrument cluster gauge and an eyelet that is connected to the frame on the opposite side of the DC/DC converter 1 (standard). An OP AMP inside the instrument cluster gauge converts voltage to amperage from any place where leakage is detected. Any current above 0.1mA will set the electrical leakage indicator. Any part of the 72 volt harness has the potential for leakage detection. The 12 volt harness has the potential for leakage detection at the accelerator potentiometer and the motor tachometer/speed sensor. Vehicles equipped with the optional power point will have a DC/DC converter 2 (optional). The DC/DC converter 2 (optional) also has the potential for leakage detection.

The following components and harnesses are to be checked for electrical leakage in this procedure:

- Contactor coil
- Instrument cluster gauge
- Motor controller
- DC/DC converter 1 (standard)
- DC/DC converter 2 (optional)
- Motor
- Motor tachometer/speed sensor
- Accelerator potentiometer
- Charger
- 72 volt harness
- Batteries

Circuit Schematic

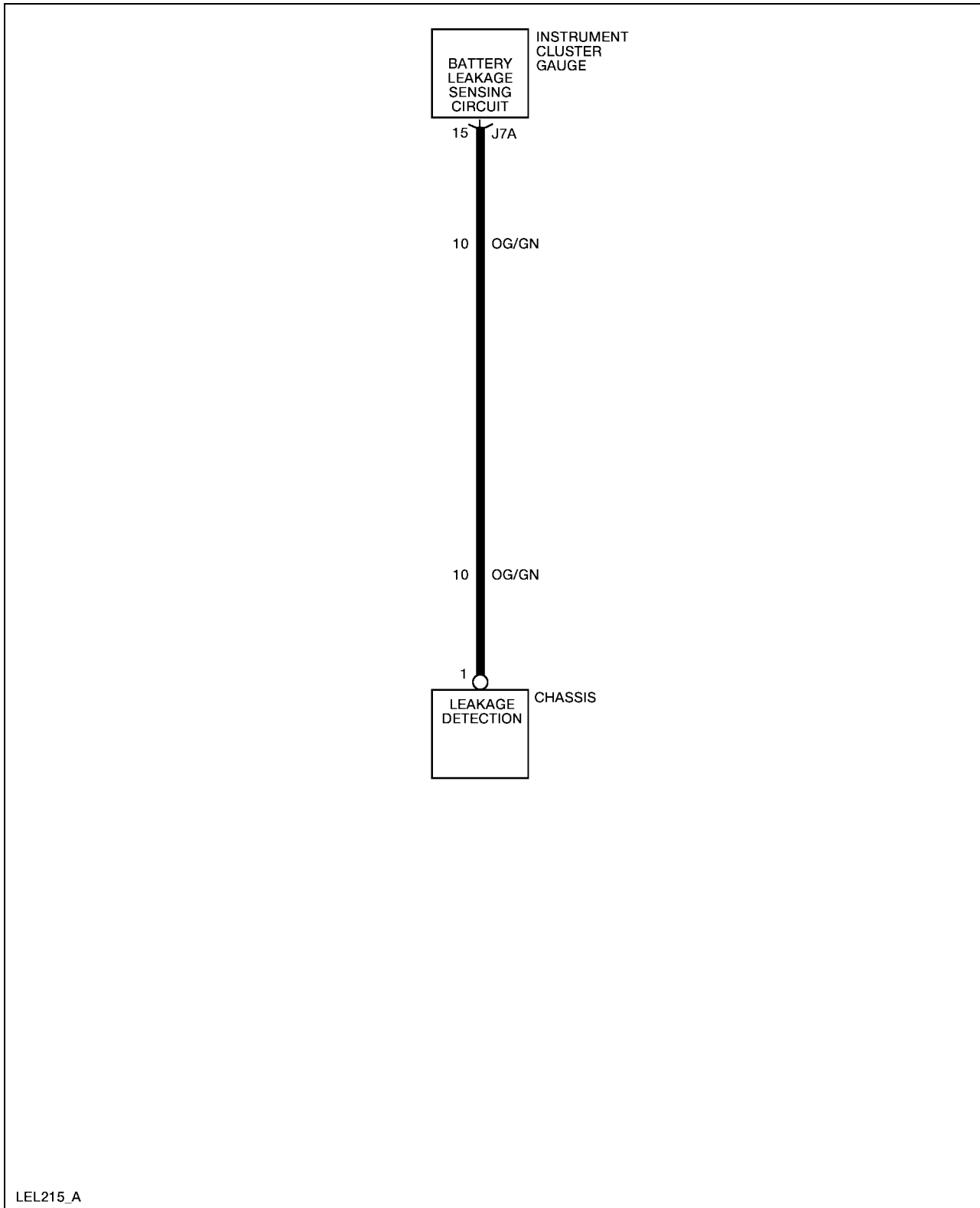

LEL215_A

Required Tools

High Voltage Insulated Gloves	100-F036 or equivalent
Face Shield	100-F035 or equivalent

Guidelines to diagnose electrical leakage:

1. Service disconnect switch must be in the ON position to observe the electrical leakage indicator located on the face of the instrument cluster gauge.
2. Before disconnecting any component, you must first place the service disconnect switch in the OFF position.
3. Check all connectors and related wiring for partially seated terminals, connectors not mating properly and for dirt, moisture or corrosion. For proper contact, terminal(s) must be free of all foreign material. Wait at least 2 minutes after all debris has been cleared so that the instrument cluster gauge has enough time to detect leakage.
4. Make sure the vehicle is thoroughly dry before attempting electrical leakage diagnosis. Electrical leakage may be detected if certain electrical connectors are exposed to moisture due to rain or washing of the vehicle. This will cause the electrical leakage indicator in the instrument cluster gauge to be set.

Electrical Leakage Diagnosis

WARNING:

THE BATTERY PACK ASSEMBLY CAN DELIVER IN EXCESS OF 72 VOLTS OF DC POWER. IMPROPER HANDLING OF THE BATTERY PACK CAN RESULT IN INJURY OR FATALITY. ONLY AUTHORIZED PERSONNEL TRAINED TO WORK WITH BATTERY PACK COMPONENTS ARE PERMITTED TO HANDLE THE BATTERIES.

WARNING:

THE BATTERY PACK CONTAINS HIGH-VOLTAGE COMPONENTS AND WIRING. HIGH-VOLTAGE INSULATED SAFETY GLOVES AND FACE SHIELD MUST BE WORN WHEN PERFORMING THE FOLLOWING STEPS. FAILURE TO FOLLOW THIS WARNING MAY RESULT IN SEVERE PERSONAL INJURY OR DEATH.

Step	Action	Connector End View
1	<p>Did you read the Circuit Description and Operation?</p> <p>Yes - GO to Step 2.</p> <p>No - REFER to Circuit Description and Operation in this section.</p>	
2	<ol style="list-style-type: none"> 1. Place the service disconnect switch in the OFF position. 2. Disconnect the chassis connector. 3. Place the service disconnect switch in the ON position. 4. Set the park brake. 5. Place the drive mode selector switch in the Reverse, Turf or Drive mode and wait 10 seconds. 6. Observe the instrument cluster gauge. <p>Does the electrical leakage indicator display?</p> <p>Yes – INSTALL a new instrument cluster gauge. REFER to Instrument Cluster Gauge in this section. OPERATE the system to verify the repair.</p> <p>No – RECONNECT the chassis connector. GO to Step 3.</p>	
3	<p>Drive the vehicle while observing the instrument cluster gauge.</p> <p>Does the electrical leakage indicator display only after heavy acceleration or high motor load?</p> <p>Yes – INSTALL a new motor. REFER to Motor in the Powertrain section. OPERATE the system to verify the repair.</p> <p>No – GO to Step 4.</p>	
4	<ol style="list-style-type: none"> 1. Place the service disconnect switch in the OFF position. 2. Disconnect the motor harness connectors. 3. Place the service disconnect switch in the ON position. 4. Set the park brake. 	

Step	Action	Connector End View
	<p>5. Place the drive mode selector switch in the Reverse, Turf or Drive mode and wait 10 seconds.</p> <p>6. Observe the instrument cluster gauge.</p> <p>Does the electrical leakage indicator display?</p> <p>Yes – GO to Step 5.</p> <p>No – INSTALL a new motor. REFER to Motor in the Powertrain section. OPERATE the system to verify the repair.</p>	
5	<p>1. Place the service disconnect switch in the OFF position.</p> <p>2. Reconnect the motor harness connectors.</p> <p>3. Disconnect the motor controller harness connector.</p> <p>4. Place the service disconnect switch in the ON position.</p> <p>5. Set the park brake.</p> <p>6. Place the drive mode selector switch in the Reverse, Turf or Drive mode and wait 10 seconds.</p> <p>7. Observe the instrument cluster gauge.</p> <p>Does the electrical leakage indicator display?</p> <p>Yes – GO to Step 6.</p> <p>No – INSTALL a new motor controller. REFER to Motor Controller in the Powertrain section. OPERATE the system to verify the repair.</p>	
6	<p>1. Place the service disconnect switch in the OFF position.</p> <p>2. Reconnect the motor controller harness connector.</p> <p>3. Disconnect the DC/DC converter 1 (standard).</p> <p>4. Place the service disconnect switch in the ON position.</p> <p>5. Place the drive mode selector switch in the Reverse, Turf or Drive position and wait 10 seconds.</p> <p>6. Observe the instrument cluster gauge.</p> <p>Is the electrical leakage indicator displayed?</p>	

Step	Action	Connector End View
	<p>Yes – If vehicle is equipped with DC/DC converter 2 (optional), GO to Step 7.</p> <p>If the vehicle is not equipped with DC/DC converter 2 (optional), GO to Step 8.</p> <p>No – INSTALL a new DC/DC converter 1 (standard). REFER to DC/DC Converter 1 (Standard) in this section. OPERATE the system to verify the repair.</p>	
7	<ol style="list-style-type: none"> 1. Place the service disconnect switch in the OFF position. 2. Reconnect the DC/DC converter 1 (standard) harness connector. 3. Disconnect the DC/DC converter 2 (optional). 4. Place the service disconnect switch in the ON position. 5. Place the drive mode selector switch in the Reverse, Turf or Drive position and wait 10 seconds. 6. Observe the instrument cluster gauge. <p>Is the electrical leakage indicator displayed?</p> <p>Yes - GO to Step 8.</p> <p>No - INSTALL a new DC/DC converter 2 (optional). REFER to DC/DC Converter (Optional) in this section. OPERATE the system to verify the repair.</p>	
8	<ol style="list-style-type: none"> 1. Place the service disconnect switch in the OFF position. 2. Reconnect the DC/DC converter 2 (optional) (if equipped) and the DC/DC converter 1 (standard) harness connectors. 3. Disconnect the charger harness connector. 4. Place the service disconnect switch in the ON position. 5. Place the drive mode selector switch in the Reverse, Turf or Drive position and wait 10 seconds. 	

Step	Action	Connector End View
	<p>6. Observe the instrument cluster gauge. Is the electrical leakage indicator displayed? Yes - GO to Step 9. No - INSTALL a new charger. REFER to Charger in this section. OPERATE the system to verify the repair.</p>	
9	<p>1. Place the service disconnect switch in the OFF position. 2. Reconnect the charger harness connector. 3. Disconnect the accelerator potentiometer harness connector. 4. Place the service disconnect switch in the ON position. 5. Place the drive mode selector switch in the Reverse, Turf or Drive position and wait 10 seconds. 6. Observe the instrument cluster gauge. Is the electrical leakage indicator displayed? Yes – GO to Step 10. No – INSTALL a new accelerator potentiometer. REFER to Accelerator Potentiometer in the Powertrain section. OPERATE the system to verify the repair.</p>	
10	<p>1. Place the service disconnect switch in the OFF position. 2. Reconnect the accelerator potentiometer harness connector. 3. Disconnect the motor tachometer/speed sensor harness connector. 4. Place the service disconnect switch in the ON position. 5. Place the drive mode selector switch in the Reverse, Turf or Drive position and wait 10 seconds. 6. Observe the instrument cluster gauge. Is the electrical leakage indicator displayed? Yes - GO to Step 11.</p>	

Step	Action	Connector End View
	<p>No - INSTALL a new motor tachometer/speed sensor. REFER to Motor Tachometer/Speed Sensor in the Powertrain section. OPERATE the system to verify the repair.</p>	
11	<ol style="list-style-type: none"> 1. Place the service disconnect switch in the OFF position. 2. Reconnect the motor tachometer/speed sensor harness connector. 3. Disconnect the contactor coil harness connectors. 4. Place the service disconnect switch in the ON position. 5. Place the drive mode selector switch in the Reverse, Turf or Drive position and wait 10 seconds. 6. Observe the instrument cluster gauge. <p>Is the electrical leakage indicator displayed?</p> <p>Yes – GO to Step 12.</p> <p>No - INSTALL a new contactor coil. REFER to Contactor in this section. OPERATE the system to verify the repair.</p>	
12	<ol style="list-style-type: none"> 1. Place the service disconnect switch in the OFF position. 2. Reconnect the motor tachometer/speed sensor harness connector. 3. Clean battery cases and battery compartment to make sure there is no dirt, moisture or corrosion buildup that could create an electrical leak path. 4. Place the service disconnect switch in the ON position. 5. Place the drive mode selector switch in the Reverse, Turf or Drive position and wait 10 seconds. 6. Observe the instrument cluster gauge. <p>Is the electrical leakage indicator displayed?</p> <p>Yes – INSTALL a new 72 volt harness. REFER to Wiring Harnesses in this section. OPERATE the system to verify</p>	

Step	Action	Connector End View
	the repair. No – GO to Step 13.	
13	Connect the positive lead of a DVOM to the positive terminal of the first battery (from the negative end of the battery pack). Connect the negative lead of the DVOM to the vehicle chassis. Does the DVOM display negative voltage? Yes – REMOVE and CLEAN the battery with a baking soda solution. REINSTALL the battery and RETEST to verify the repair. No – MOVE the positive lead of the DVOM to the positive terminal of the next battery of the battery pack. CHECK each battery until a negative voltage is displayed on the DVOM. REMOVE and CLEAN the battery that displays a negative voltage. RETEST to verify the repair.	

Accelerator Potentiometer

Circuit Description and Operation

When the contactor is turned on, the accelerator potentiometer receives 12 volts from the instrument cluster gauge. When the accelerator potentiometer pedal is pressed, a 12 volt signal is sent from the accelerator potentiometer to the motor controller. Two additional voltage signals are also sent from the accelerator potentiometer to the motor controller. These additional signals will vary depending on accelerator potentiometer pedal position. The motor controller uses these signals to control motor speed.

Circuit Schematic

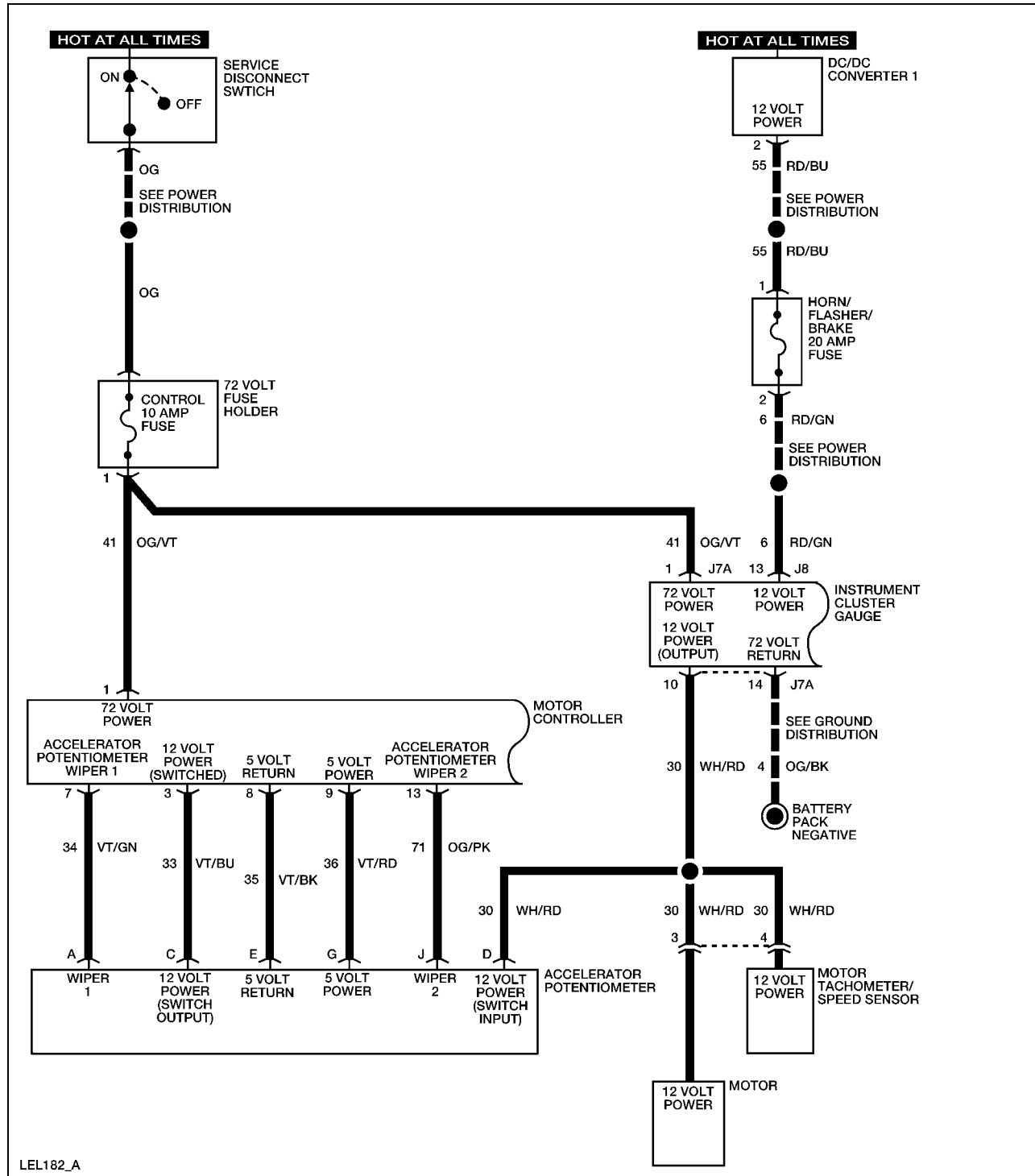

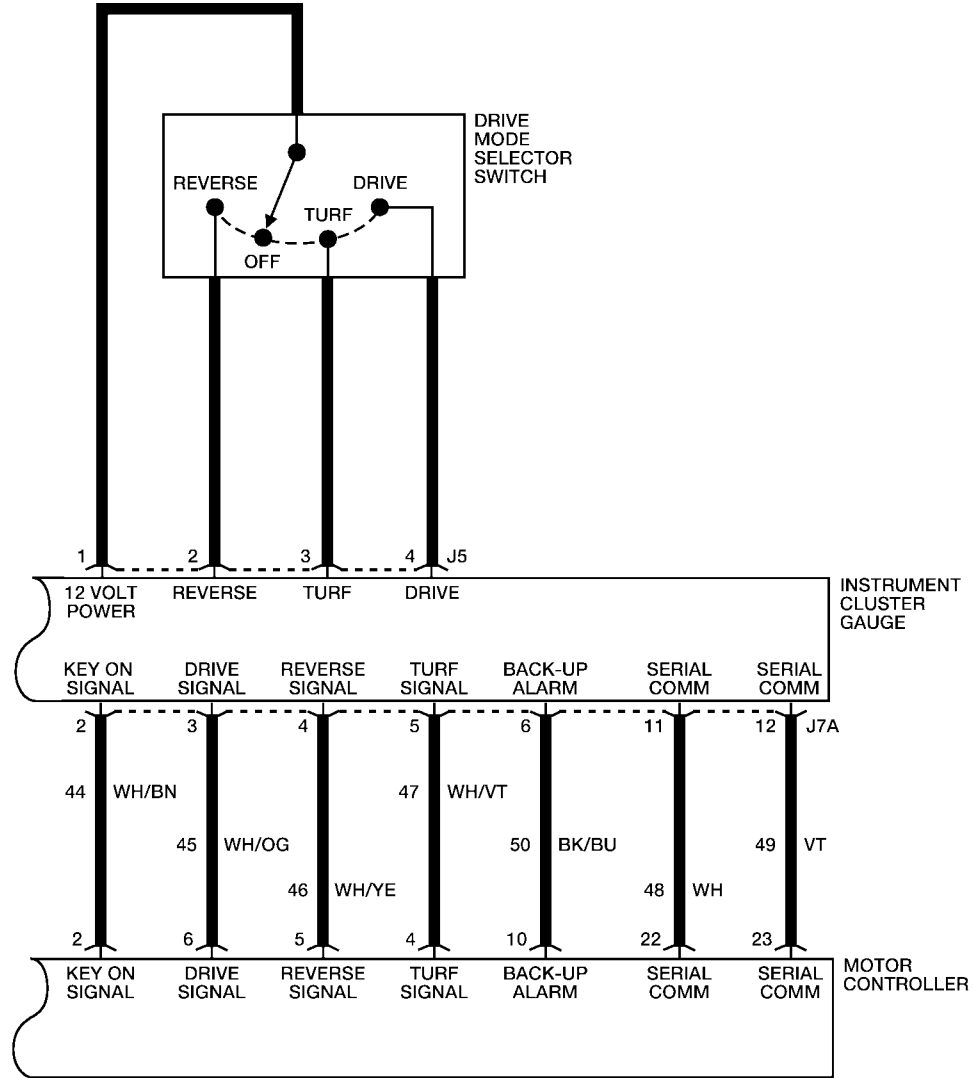

LEL219_A

Required Tools

High Voltage Insulated Gloves	100-F036 or equivalent
Face Shield	100-F035 or equivalent

System Check

Functional components in the accelerator potentiometer system are:

- Service disconnect switch
- Control fuse
- Motor controller
- Instrument cluster gauge
- Accelerator potentiometer
- Motor tachometer/speed sensor

Guidelines to diagnose the accelerator potentiometer system:

1. Verify the concern.
2. Check the fuse(s).
3. Check all connectors and related wiring for partially seated terminals, connectors not mating properly and for dirt, moisture or corrosion. For proper contact, terminal(s) must be free of all foreign material.
4. Verify service disconnect switch is in ON position.
5. Check for any diagnostic trouble codes. Refer to [Retrieving and Clearing DTCs](#).

If the concern still exists, refer to the following table:

Symptom Chart

Symptom	Possible Causes	Action
Vehicle speed does not change when accelerator potentiometer position changes.	<ul style="list-style-type: none"> Accelerator potentiometer Connectors and related wiring 	GO to Accelerator Potentiometer Inoperative.

Accelerator Potentiometer Inoperative

WARNING:

THE BATTERY PACK ASSEMBLY CAN DELIVER IN EXCESS OF 72 VOLTS OF DC POWER. IMPROPER HANDLING OF THE BATTERY PACK CAN RESULT IN INJURY OR FATALITY. ONLY AUTHORIZED PERSONNEL TRAINED TO WORK WITH BATTERY PACK COMPONENTS ARE PERMITTED TO HANDLE THE BATTERIES.

WARNING:

THE BATTERY PACK CONTAINS HIGH-VOLTAGE COMPONENTS AND WIRING. HIGH-VOLTAGE INSULATED SAFETY GLOVES AND FACE SHIELD MUST BE WORN WHEN PERFORMING THE FOLLOWING STEPS. FAILURE TO FOLLOW THIS WARNING MAY RESULT IN SEVERE PERSONAL INJURY OR DEATH.

Step	Action	Connector End View
1.	Did you read the Circuit Description and Operation? Yes - GO to Step 2. No - REFER to Circuit Description and Operation in this section.	
2.	<ol style="list-style-type: none"> Disconnect the motor controller harness connector and the accelerator potentiometer harness connector. Connect a DVOM between the motor controller harness connector terminal 7 and the accelerator potentiometer harness connector terminal A. Connect a DVOM between the motor controller harness connector terminal 8 and the accelerator potentiometer harness connector terminal E. Connect a DVOM between the motor controller harness connector terminal 9 and the accelerator potentiometer harness connector terminal G. Connect a DVOM between the motor controller harness 	Motor Controller Accelerator Potentiometer

Step	Action	Connector End View
	<p>connector terminal 13 and the accelerator potentiometer harness connector terminal J</p> <p>Does continuity exist?</p> <p>Yes – GO to Step 3.</p> <p>No – INSTALL a new 72 volt harness. REFER to Wiring Harnesses in this section. OPERATE the system to verify the repair.</p>	
3.	<ol style="list-style-type: none"> 1. Reconnect the accelerator potentiometer harness connector. 2. Connect a DVOM between the motor controller harness connector terminal 7 and terminal 8. <p>Does the DVOM display between 1.9k and 3.9k ohms with the accelerator potentiometer pedal raised and between 3.7k and 5.7k ohms with the accelerator potentiometer pedal pressed?</p> <p>Yes – GO to Step 4.</p> <p>No – INSTALL a new accelerator potentiometer. REFER to Accelerator Potentiometer in the Powertrain section. OPERATE the system to verify the repair.</p>	Motor Controller Accelerator Potentiometer
4.	<p>Connect a DVOM between the motor controller harness connector terminal 8 and terminal 13.</p> <p>Does the DVOM display between 3.7k and 5.7k ohms with the accelerator potentiometer pedal raised and between 1.9k and 3.9k ohms with the accelerator potentiometer pedal pressed?</p> <p>Yes – GO to Step 5.</p> <p>No – INSTALL a new accelerator potentiometer. REFER to Accelerator Potentiometer in the Powertrain section. OPERATE the system to verify the repair.</p>	Motor Controller
5.	<p>Connect a DVOM between the motor controller harness connector terminal 8 and terminal 9.</p> <p>Does the DVOM display less than 5k ohms?</p> <p>Yes – INSTALL a new motor controller. REFER to Motor Controller in the Powertrain section. OPERATE the system to verify the repair.</p> <p>No – INSTALL a new accelerator potentiometer. REFER to Accelerator Potentiometer in the Powertrain section. OPERATE the system to verify the repair.</p>	Motor Controller

DTC 05

Description:

Accelerator potentiometer switch fails to close.

Symptom:

Motor controller will not operate.

Possible cause(s):

- Accelerator potentiometer
- Connectors and related wiring

WARNING:

THE BATTERY PACK ASSEMBLY CAN DELIVER IN EXCESS OF 72 VOLTS OF DC POWER. IMPROPER HANDLING OF THE BATTERY PACK CAN RESULT IN INJURY OR FATALITY. ONLY AUTHORIZED PERSONNEL TRAINED TO WORK WITH BATTERY PACK COMPONENTS ARE PERMITTED TO HANDLE THE BATTERIES.

WARNING:

THE BATTERY PACK CONTAINS HIGH-VOLTAGE COMPONENTS AND WIRING. HIGH-VOLTAGE INSULATED SAFETY GLOVES AND FACE SHIELD MUST BE WORN WHEN PERFORMING THE FOLLOWING STEPS. FAILURE TO FOLLOW THIS WARNING MAY RESULT IN SEVERE PERSONAL INJURY OR DEATH.

Step	Action	Connector End View
1	<p>Did you read the Circuit Description and Operation? Yes - GO to Step 2. No - REFER to Circuit Description and Operation in this section.</p>	
2	<ol style="list-style-type: none"> 1. Disconnect the motor controller harness connector. 2. Set the park brake. 3. Place the drive mode selector switch in the Reverse, Turf or Drive position. 4. Connect a DVOM between the motor controller harness connector terminal 3 and the vehicle chassis. <p>Does the DVOM display approximately 12 volts with the</p>	Motor Controller

Step	Action	Connector End View
	<p>accelerator potentiometer pedal pressed?</p> <p>Yes – INSTALL a new motor controller. REFER to Motor Controller in the Powertrain section. OPERATE the system to verify the repair.</p> <p>No – GO to Step 3.</p>	
3	<ol style="list-style-type: none"> 1. Disconnect the accelerator potentiometer harness connector. 2. Connect a DVOM between the accelerator potentiometer harness connector terminal C and terminal D. <p>Does the DVOM display approximately 3.3k ohms with the accelerator potentiometer pedal pressed?</p> <p>Yes – GO to Step 4.</p> <p>No – INSTALL a new accelerator potentiometer. REFER to Accelerator Potentiometer in the Powertrain section. OPERATE the system to verify the repair.</p>	Accelerator Potentiometer
4	<p>Connect a DVOM between the accelerator potentiometer harness connector terminal D and the vehicle chassis.</p> <p>Does the DVOM display approximately 12 volts?</p> <p>Yes – INSTALL a new 72 volt harness. REFER to Wiring Harnesses in this section. OPERATE the system to verify the repair.</p> <p>No – GO to Step 5.</p>	Accelerator Potentiometer
5	<p>Connect a DVOM between the instrument cluster gauge harness connector J7A (back probe) terminal 10 and the vehicle chassis.</p> <p>Does the DVOM display approximately 12 volts?</p> <p>Yes – INSTALL a new 72 volt harness. REFER to Wiring Harnesses in this section. OPERATE the system to verify the repair.</p> <p>No – INSTALL a new instrument cluster gauge. REFER to Instrument Cluster Gauge in this section. OPERATE the system to verify the repair.</p>	Instrument Cluster Gauge – J7A

DTC 06**Description:**

Accelerator potentiometer pedal is pressed with no direction signal given to the controller.

Symptom:

Motor controller will not operate.

Possible cause(s):

- Accelerator potentiometer
- Connectors and related wiring
- Instrument cluster gauge

WARNING:

THE BATTERY PACK ASSEMBLY CAN DELIVER IN EXCESS OF 72 VOLTS OF DC POWER. IMPROPER HANDLING OF THE BATTERY PACK CAN RESULT IN INJURY OR FATALITY. ONLY AUTHORIZED PERSONNEL TRAINED TO WORK WITH BATTERY PACK COMPONENTS ARE PERMITTED TO HANDLE THE BATTERIES.

WARNING:

THE BATTERY PACK CONTAINS HIGH-VOLTAGE COMPONENTS AND WIRING. HIGH-VOLTAGE INSULATED SAFETY GLOVES AND FACE SHIELD MUST BE WORN WHEN PERFORMING THE FOLLOWING STEPS. FAILURE TO FOLLOW THIS WARNING MAY RESULT IN SEVERE PERSONAL INJURY OR DEATH.

Step	Action	Connector End View
1	Did you perform the Diagnostic System Check? Yes - GO to Step 2. No - REFER to Diagnostic System Check in this section.	
2	1. Set the park brake. 2. Place the drive mode selector switch in the Reverse position. 3. Disconnect the motor controller harness connector. 4. Connect a DVOM between the motor controller harness connector terminal 5 and the vehicle chassis.	Motor Controller

Step	Action	Connector End View
	<p>Does the DVOM display approximately 12 volts? Yes - GO to Step 3. No - GO to Step 4.</p>	
3	<p>1. Place the drive mode selector switch in the Drive position.</p> <p>2. Connect a DVOM between the motor controller harness connector terminal 6 and the vehicle chassis.</p> <p>Does the DVOM display approximately 12 volts? Yes - INSTALL a new motor controller. REFER to Motor Controller in the Powertrain section. OPERATE system to verify the repair. No - GO to Step 5.</p>	Motor Controller
4	<p>1. Disconnect the instrument cluster gauge harness connector J7A.</p> <p>2. Connect a DVOM between the instrument cluster gauge harness connector J7A terminal 4 and the motor controller harness connector terminal 5.</p> <p>Does continuity exist? Yes - INSTALL a new instrument cluster gauge. REFER to Instrument Cluster Gauge in this section. OPERATE the system to verify the repair. No - INSTALL a new 72 volt harness. REFER to Wiring Harnesses in this section. OPERATE the system to verify the repair.</p>	Instrument Cluster Gauge – J7A Motor Controller
5	<p>Connect a DVOM between the instrument cluster gauge harness connector J7A terminal 3 and the motor controller harness connector terminal 6.</p> <p>Does continuity exist? Yes - INSTALL a new instrument cluster gauge. REFER to Instrument Cluster Gauge in this section. OPERATE the system to verify the repair. No - INSTALL a new 72 volt harness. REFER to Wiring Harnesses in this section. OPERATE the system to verify the repair.</p>	Instrument Cluster Gauge – J7A Motor Controller

DTC 08

Description:

Accelerator potentiometer input voltage to the motor controller is greater than 1.25 volts on power-up after initial drive mode selector switch closure.

Symptom:

Motor controller will not operate.

Possible cause(s):

- Accelerator potentiometer
- Connectors and related wiring
- Motor controller

Step	Action	Connector End View
1	Did you perform the Diagnostic System Check? Yes - GO to Step 3. No - REFER to Diagnostic System Check in this section.	
2	1. Disconnect the motor controller harness connector. 2. Disconnect the accelerator potentiometer harness connector. 3. Connect a DVOM between the motor controller harness connector terminal 7 and each of the other terminals of the motor controller harness connector. Does continuity exist between circuit 34 and any other circuit in the motor controller harness connector? Yes - INSTALL a new 72 volt harness. REFER to Wiring Harnesses in this section. OPERATE the system to verify the repair. No – GO to Step 3.	Motor Controller Accelerator Potentiometer
3	Connect a DVOM between the motor controller terminal 7 and the vehicle chassis. Does the DVOM display greater than approximately 1.25	Motor Controller

Step	Action	Connector End View
	volts? Yes - INSTALL a new motor controller. REFER to Motor Controller in the Powertrain section. OPERATE the system to verify the repair. No – INSTALL a new accelerator potentiometer. REFER to Accelerator Potentiometer in the Powertrain section. OPERATE the system to verify the repair.	

DTC 11

Description:

Accelerator potentiometer switch closed on power-up after initial drive mode selector switch closure.

Symptom:

Motor controller will not operate.

Possible cause(s):

- Accelerator potentiometer
- Connectors and related wiring
- Motor controller

Note: Check all vehicle fuses before performing this diagnostic procedure.

WARNING:

THE BATTERY PACK ASSEMBLY CAN DELIVER IN EXCESS OF 72 VOLTS OF DC POWER. IMPROPER HANDLING OF THE BATTERY PACK CAN RESULT IN INJURY OR FATALITY. ONLY AUTHORIZED PERSONNEL TRAINED TO WORK WITH BATTERY PACK COMPONENTS ARE PERMITTED TO HANDLE THE BATTERIES.

WARNING:

THE BATTERY PACK CONTAINS HIGH-VOLTAGE COMPONENTS AND WIRING. HIGH-VOLTAGE INSULATED SAFETY GLOVES AND FACE SHIELD MUST BE WORN WHEN PERFORMING THE FOLLOWING STEPS. FAILURE TO FOLLOW THIS WARNING MAY RESULT IN SEVERE PERSONAL INJURY OR DEATH.

Step	Action	Connector End View
1	<p>Did you perform the Diagnostic System Check?</p> <p>Yes - GO to Step 2.</p> <p>No - Refer to Diagnostic System Check in this section.</p>	
2	<ol style="list-style-type: none"> 1. Disconnect the motor controller harness connector. 2. Disconnect the accelerator potentiometer harness connector. 3. Connect a DVOM between the motor controller harness connector terminal 7 and each of the other terminals of the motor controller harness connector. <p>Does continuity exist between circuit 33 and any other circuit in the motor controller harness connector?</p> <p>Yes - INSTALL a new 72 volt harness. REFER to Wiring Harnesses in this section. OPERATE the system to verify the repair.</p> <p>No - GO to Step 3.</p>	<p>Motor Controller</p> <p>Accelerator Potentiometer</p>
3	<p>Connect a DVOM between the motor controller harness connector terminal 3 and the vehicle chassis.</p> <p>Does the DVOM display greater than approximately 7.2 volts?</p> <p>Yes - INSTALL a new motor controller. REFER to Motor Controller in the Powertrain section. OPERATE the system to verify the repair.</p> <p>No - INSTALL a new accelerator potentiometer. REFER to Accelerator Potentiometer in the Powertrain section. OPERATE the system to verify the repair.</p>	<p>Motor Controller</p>

Battery

Circuit Description and Operation

72 volt power is supplied a pack by six 12 volt batteries connected in series. The battery pack is divided into two banks of three batteries, which are connected by a 400 amp megafuse.

Circuit Schematic

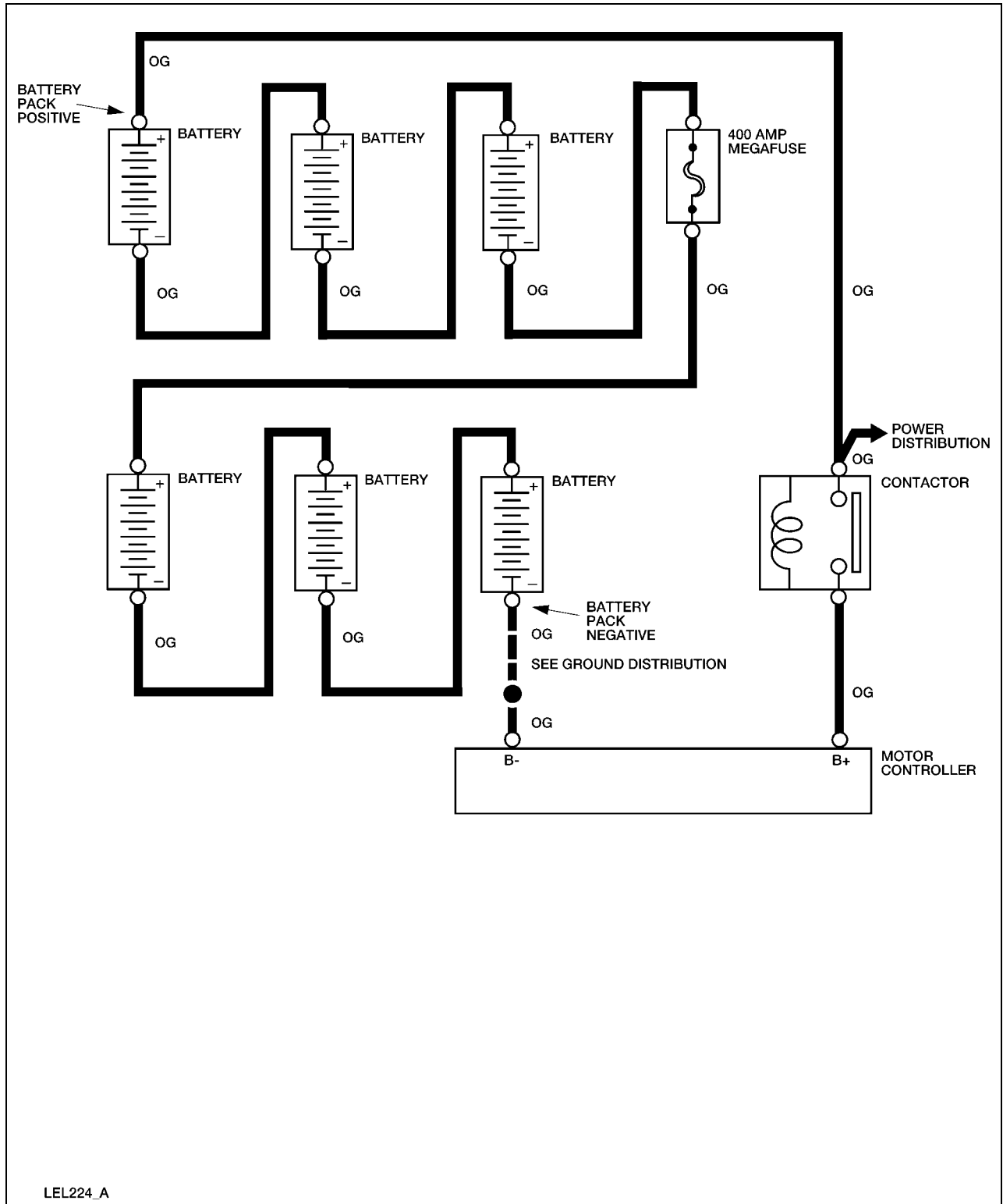

LEL224_A

Required Tools

High Voltage Insulated Gloves	100-F036 or equivalent
Face Shield	100-F035 or equivalent

System Check

Functional components in the battery system are:

- Batteries
- 400 amp megafuse
- Contactor coil

Guidelines to diagnose the battery system:

1. Verify the concern.
2. Check the fuse(s).
3. Check all connectors and related wiring for partially seated terminals, connectors not mating properly and for dirt, moisture or corrosion. For proper contact, terminal(s) must be free of all foreign material.
4. Check for any diagnostic trouble codes. Refer to [Retrieving and Clearing DTCs](#) in this section.

If the concern still exists, refer to the following table.

Symptom Chart

Symptom	Possible Causes	Action
The vehicle does not operate — no power	<ul style="list-style-type: none"> • Battery • 400 amp megafuse 	GO to Battery Test .

Selecting Battery Type

When the maintenance-free battery mode is selected, the battery water reminder indicator will not be displayed on the instrument cluster gauge. If the flooded battery mode is selected, the battery water reminder will be displayed under either of the following conditions:

- When the drive mode selector switch is turned to the Reverse, Turf or Drive position and the instrument cluster gauge performs an indicator test.

- When the vehicle has been driven at least 300 miles (483 km) since the last reset or activation of the battery water reminder.

To toggle the battery type between flooded battery mode and maintenance-free battery mode, perform the following:

1. While pressing the Select/Reset button, place the drive mode selector switch in the Drive position.
2. Release the Select/Reset button within 5 seconds.
3. Place the drive mode selector switch in the Reverse position.
4. Press and release the Select/Reset button to toggle between the flooded battery mode and the maintenance-free battery mode.
5. To exit Selecting Battery Type, place the drive mode selector switch in the OFF position and either press the Select/Reset button or wait 10 seconds.

The battery water reminder indicator is the only indicator displayed when the instrument cluster gauge is in Selecting Battery Type mode.

Battery Test

WARNING:

THE BATTERY PACK ASSEMBLY CAN DELIVER IN EXCESS OF 72 VOLTS OF DC POWER. IMPROPER HANDLING OF THE BATTERY PACK CAN RESULT IN INJURY OR FATALITY. ONLY AUTHORIZED PERSONNEL TRAINED TO WORK WITH BATTERY PACK COMPONENTS ARE PERMITTED TO HANDLE THE BATTERIES.

WARNING:

THE BATTERY PACK CONTAINS HIGH-VOLTAGE COMPONENTS AND WIRING. HIGH-VOLTAGE INSULATED SAFETY GLOVES AND FACE SHIELD MUST BE WORN WHEN PERFORMING THE FOLLOWING STEPS. FAILURE TO FOLLOW THIS WARNING MAY RESULT IN SEVERE PERSONAL INJURY OR DEATH.

The battery test is done by measuring individual battery voltages with a calibrated voltmeter. This test determines the general state of charge and battery condition quickly. Use the Rotunda Alternator, Regulator Battery and Starter Tester (ARBST) 010-00725 or equivalent. Apply a 50 amp load to each of the batteries for no more than 10 seconds. Read the voltage before removing the load. A well-charged battery should maintain at least 12 volts. If the meter reads less than approximately 11.5 volts, the battery is not charged adequately, or it may be defective. Charge the battery using a battery charger and perform the test again. When charging the individual batteries, make sure the battery charger leads are clamped to the bases of the battery posts and

not the threaded studs. If battery voltage is not within specification, replace the battery. Refer to [Batteries](#) in this section. Charge the new battery using a 12 volt battery charger and perform the test again.

DTC 15

Description:

Battery voltage is less than 68.3 volts at initial drive mode selector switch closure.

Symptom:

Motor controller will not operate.

Possible cause(s):

Discharged or inoperative battery or batteries.

Note:

Check all vehicle fuses before performing this diagnostic procedure.

WARNING:

THE BATTERY PACK ASSEMBLY CAN DELIVER IN EXCESS OF 72 VOLTS OF DC POWER. IMPROPER HANDLING OF THE BATTERY PACK CAN RESULT IN INJURY OR FATALITY. ONLY AUTHORIZED PERSONNEL TRAINED TO WORK WITH BATTERY PACK COMPONENTS ARE PERMITTED TO HANDLE THE BATTERIES.

WARNING:

THE BATTERY PACK CONTAINS HIGH-VOLTAGE COMPONENTS AND WIRING. HIGH-VOLTAGE INSULATED SAFETY GLOVES AND FACE SHIELD MUST BE WORN WHEN PERFORMING THE FOLLOWING STEPS. FAILURE TO FOLLOW THIS WARNING MAY RESULT IN SEVERE PERSONAL INJURY OR DEATH.

Step	Action	Connector End View
1	Did you perform the Diagnostic System Check? Yes – GO to Step 2. No - REFER to Diagnostic System Check in this section.	
2	Connect a DVOM between the battery pack positive and the battery pack negative. Is the voltage less than 68.3 volts?	

Step	Action	Connector End View
	<p>Yes – If the vehicle is equipped with flooded batteries, GO to Step 3. If the vehicle is equipped with maintenance-free batteries, GO to Step 4.</p> <p>No – The system is OK.</p>	
3	<p>Inspect the batteries for the proper water level. Refer to Battery Fill Procedure in the General Information section.</p> <p>Is the water level OK?</p> <p>Yes - GO to Step 4.</p> <p>No - Fill the batteries to the correct level with de-ionized or distilled water. GO to Step 4.</p>	
4	<ol style="list-style-type: none"> 1. Fully charge each individual battery using a battery charger. 2. Connect a DVOM between the battery pack positive and the battery pack negative. <p>Is the voltage less than 68.3 volts?</p> <p>Yes – REFER to Battery Test in this section.</p> <p>No – The system is OK.</p>	

DTC 16

Description:

Battery voltage is greater than 86 volts at initial drive mode selector switch closure.

Symptom:

Motor controller will not operate.

Possible cause(s):

- GFCI charger cord is connected to the charger.
- Battery voltage too high.

WARNING:

THE BATTERY PACK ASSEMBLY CAN DELIVER IN EXCESS OF 72 VOLTS OF DC POWER. IMPROPER HANDLING OF THE BATTERY PACK CAN RESULT IN INJURY OR FATALITY. ONLY AUTHORIZED PERSONNEL TRAINED TO WORK WITH BATTERY PACK COMPONENTS ARE PERMITTED TO HANDLE THE BATTERIES.

WARNING:

THE BATTERY PACK CONTAINS HIGH-VOLTAGE COMPONENTS AND WIRING. HIGH-VOLTAGE INSULATED SAFETY GLOVES AND FACE SHIELD MUST BE WORN WHEN PERFORMING THE FOLLOWING STEPS. FAILURE TO FOLLOW THIS WARNING MAY RESULT IN SEVERE PERSONAL INJURY OR DEATH.

Step	Action	Connector End View
1	Did you perform the Diagnostic System Check? Yes - GO to Step 2. No - REFER to Diagnostic System Check in this section.	
2	Connect a DVOM between the battery pack positive and the battery pack negative. Is the voltage greater than 86 volts? Yes – REFER to Battery Test , in this section, to check the individual batteries for overcharge. No – The system is OK.	

Charging

Circuit Description and Operation

The battery charger receives 120-volt AC power from an external standard grounded 3-prong outlet and converts it to DC power as required to charge the vehicle battery pack. After properly connecting the vehicle to the receptacle, the charger will initiate a four stage charging process. In the first stage, the battery pack is tested. If the battery pack passes, the charger determines the appropriate charging rate, depending upon the voltage of the battery pack, and charges the battery pack. In the second and third stages, the voltage is regulated, and charging is completed. The battery pack is maintained at the full state of charge in the fourth stage. If the vehicle is left connected to the charger, the charger will automatically reinitiate a new charge cycle every 28 days. The rate at which the battery pack charges will vary, depending on the type of batteries installed. To ensure a fully charged battery pack, the vehicle should be charged continuously and uninterrupted for 14 hours. The instrument cluster gauge must be set for the type of batteries that are installed in the vehicle to prevent excessive charge time or damage to the batteries. Refer to [Battery Type Reprogramming](#) in this section. The battery charger should only be operated with the supplied GFCI charger cord. If the battery charger detects current from the GFCI charger cord, it will send a signal to the instrument cluster gauge. The instrument cluster gauge will then display the charging indicator and prevent the vehicle from being driven.

Circuit Schematic

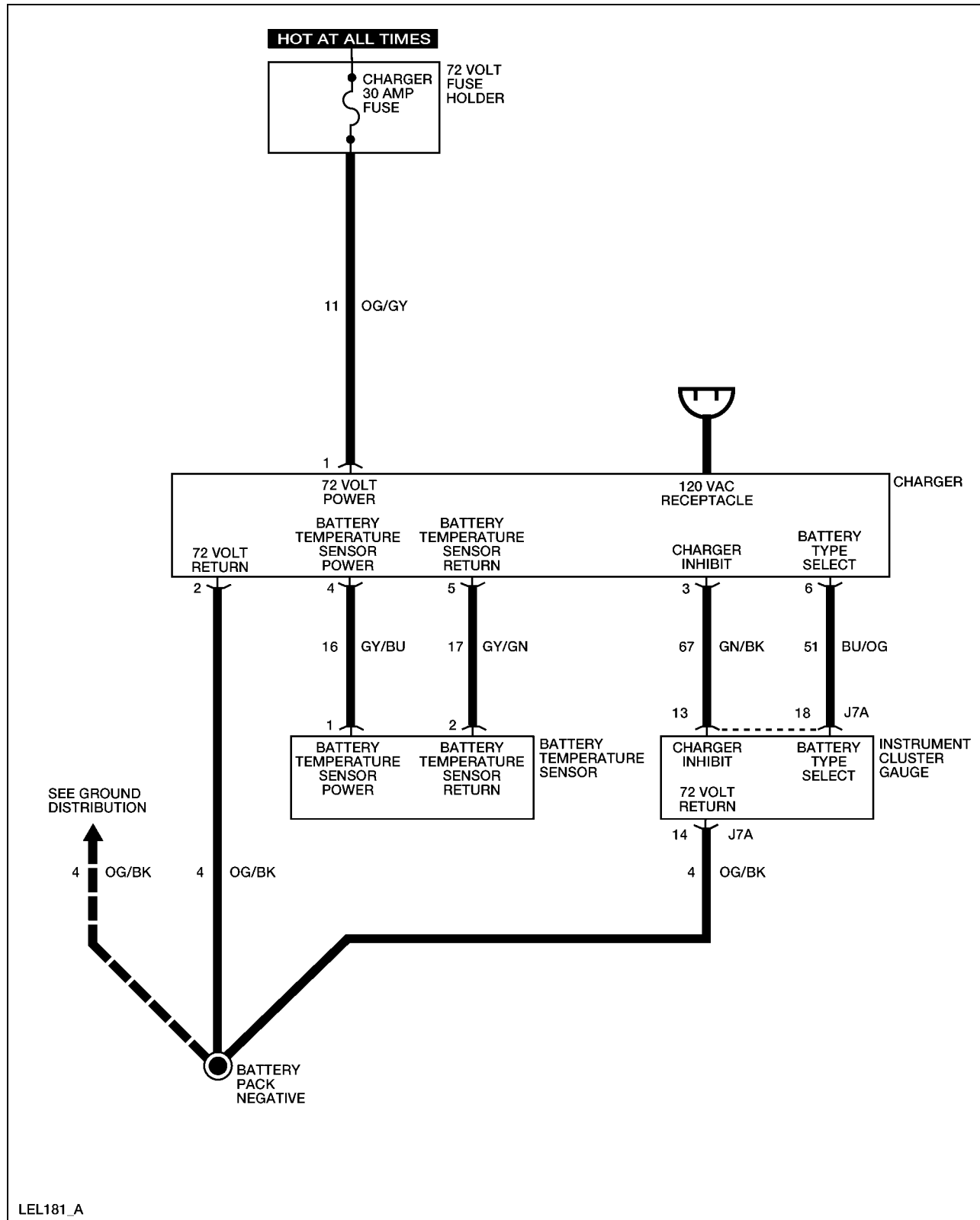

Required Tools

High Voltage Insulated Gloves	100-F036 or equivalent
Face Shield	100-F035 or equivalent

System Check

Functional components in the charging system are:

- GFCI cord
- Charger
- Service disconnect switch
- Battery temperature sensor
- Charger fuse
- Fuse cap
- Related wiring

Guidelines to diagnose the charging system:

1. Verify the concern.
2. Check the fuse(s).
3. Check all connectors and related wiring for partially seated terminals, connectors not mating properly and for dirt, moisture or corrosion. For proper contact, terminal(s) must be free of all foreign material.
4. Service disconnect switch must be in the ON position to charge batteries.
5. Make sure the instrument cluster gauge is set for the type of batteries that are installed in the vehicle. Refer to [Battery Type Reprogramming](#) in this section.

If the concern still exists, refer to the following table:

Symptom Chart

Symptom	Possible Causes	Action
The batteries do not charge	<ul style="list-style-type: none"> • GFCI power cord • Charger fuse • Fuse cap • Charger • Battery (or batteries) • Connectors or related wiring 	GO to Charger Inoperative.
The batteries charge slowly (take too long to fully charge)	<ul style="list-style-type: none"> • Charger • Battery temperature sensor • Connectors or related wiring 	GO to Batteries Charge Slowly.
The 120VAC indicator will not display	<ul style="list-style-type: none"> • Instrument cluster gauge • Connectors or related wiring 	GO to 120VAC Energized Indicator Inoperative.

Charger Inoperative

WARNING:

THE BATTERY PACK ASSEMBLY CAN DELIVER IN EXCESS OF 72 VOLTS OF DC POWER. IMPROPER HANDLING OF THE BATTERY PACK CAN RESULT IN INJURY OR FATALITY. ONLY AUTHORIZED PERSONNEL TRAINED TO WORK WITH BATTERY PACK COMPONENTS ARE PERMITTED TO HANDLE THE BATTERIES.

WARNING:

THE BATTERY PACK CONTAINS HIGH-VOLTAGE COMPONENTS AND WIRING. HIGH-VOLTAGE INSULATED SAFETY GLOVES AND FACE SHIELD MUST BE WORN WHEN PERFORMING THE FOLLOWING STEPS. FAILURE TO FOLLOW THIS WARNING MAY RESULT IN SEVERE PERSONAL INJURY OR DEATH.

Step	Action	Connector End View
1.	Did you read the Circuit Description and Operation? Yes - GO to Step 2. No – REFER to Circuit Description and Operation in this section.	

Step	Action	Connector End View
2.	1. Disconnect the charger harness connector. 2. Connect a DVOM between the charger harness connector terminal 1 and terminal 2. Does the DVOM display approximately 72 volts? Yes – GO to Step 3. No – GO to Step 5.	Charger
3.	1. Reconnect the charger connector. 2. Connect the GFCI charger cord to the charger. 3. Verify charger operation by listening for a buzz noise and feeling for a slight vibration from the charger. Does the charger operate? Yes – GO to Step 4. No – GO to Step 8.	
4.	With the GFCI cord connected to the charger, connect a DVOM between the battery pack positive and battery pack negative. Does the voltage increase after two minutes? Yes – The system is OK. No – TEST the batteries. REFER to Battery Test in this section. If all batteries are OK, INSTALL a new charger. REFER to Charger in this section. OPERATE the system to verify the repair.	
5.	Connect a DVOM between the battery pack positive and battery pack negative. Does the DVOM display approximately 72 volts? Yes – GO to Step 6. No – TEST the batteries. REFER to Battery Test in this section.	
6.	Connect a DVOM between the charger harness connector terminal 2 and the battery pack negative. Does continuity exist? Yes – GO to Step 7.	Charger

Step	Action	Connector End View
	<p>No – INSTALL a new 72 volt harness. REFER to Wiring Harnesses in this section. OPERATE the system to verify the repair.</p>	
7.	<p>1. Perform the Power Shutdown Procedure. Refer to Power Shutdown Procedure in this section.</p> <p>2. Connect a DVOM between the charger harness connector terminal 1 and the battery pack positive.</p> <p>Does continuity exist?</p> <p>Yes – The system is OK.</p> <p>No – INSPECT the fuse cap and INSTALL a new fuse cap if necessary. If the fuse cap is OK, INSTALL a new 72 volt harness. REFER to Wiring Harnesses in this section. OPERATE the system to verify the repair.</p>	Charger
8.	<p>1. Connect a known good GFCI cord to the charger.</p> <p>2. Verify charger operation by listening for a buzz noise and feeling for a slight vibration from the charger.</p> <p>Does the charger operate?</p> <p>Yes – INSTALL a new GFCI cord. OPERATE the system to verify the repair.</p> <p>No – INSTALL a new charger. REFER to Charger in this section. OPERATE the system to verify the repair.</p>	

Batteries Charge Slowly

WARNING:

THE BATTERY PACK ASSEMBLY CAN DELIVER IN EXCESS OF 72 VOLTS OF DC POWER. IMPROPER HANDLING OF THE BATTERY PACK CAN RESULT IN INJURY OR FATALITY. ONLY AUTHORIZED PERSONNEL TRAINED TO WORK WITH BATTERY PACK COMPONENTS ARE PERMITTED TO HANDLE THE BATTERIES.

WARNING:

THE BATTERY PACK CONTAINS HIGH-VOLTAGE COMPONENTS AND WIRING. HIGH-VOLTAGE INSULATED SAFETY GLOVES AND FACE SHIELD MUST BE WORN WHEN PERFORMING THE FOLLOWING STEPS. FAILURE TO FOLLOW THIS WARNING MAY RESULT IN SEVERE PERSONAL INJURY OR DEATH.

Step	Action	Connector End View
1	<p>Did you read the Circuit Description and Operation?</p> <p>Yes - GO to Step 2.</p> <p>No – REFER to Circuit Description and Operation in this section.</p>	
2	<ol style="list-style-type: none"> 1. Perform the Power Shutdown Procedure. Refer to Power Shutdown Procedure in this section. 2. Disconnect the charger harness connector. 3. Connect a DVOM between the charger harness connector terminal 4 and terminal 5. <p>Does the DVOM display between 8k and 12k ohms at approximately 25 degrees C?</p> <p>Yes – GO to Step 3.</p> <p>No – GO to Step 4.</p>	Charger
3	<p>Measure the time required to bring batteries to a full state of charge.</p> <p>Do the batteries charge fully in 8-10 hours?</p> <p>Yes – The system is OK.</p> <p>No – TEST the batteries. REFER to Battery Test in this section. If all batteries are OK, INSTALL a new charger. REFER to Charger in this section. OPERATE the system to verify the repair.</p>	
4	<ol style="list-style-type: none"> 1. Disconnect the battery temperature sensor harness connector. 2. Connect a DVOM between the battery temperature sensor harness connector terminal 1 and terminal 2. <p>Does the DVOM display between 8k and 12k ohms at approximately 25 degrees C?</p> <p>Yes – GO to Step 5.</p> <p>No – INSTALL a new battery temperature sensor. OPERATE the system to verify the repair.</p>	Battery Temperature Sensor
5	<p>Connect a DVOM between the battery temperature sensor harness connector terminal 1 and the charger harness connector terminal 4.</p>	Battery Temperature Sensor Charger

Step	Action	Connector End View
	<p>Does continuity exist?</p> <p>Yes – GO to Step 6.</p> <p>No – REPAIR circuit 16. OPERATE the system to verify the repair.</p>	
6	<p>Connect a DVOM between the battery temperature sensor harness connector terminal 2 and the charger harness connector terminal 5.</p> <p>Does continuity exist?</p> <p>Yes – INSTALL a new charger. REFER to Charger in this section. OPERATE the system to verify the repair.</p> <p>No – REPAIR circuit 17. OPERATE the system to verify the repair.</p>	<p>Battery Temperature Sensor</p> <p>Charger</p>

Voltage Step Down

Circuit Description and Operation

The DC/DC converter 1 (standard) and DC/DC converter 2 (optional) receive 72 volt power through the DC/DC fuse when the service disconnect switch is in the ON position. The DC/DC converter 1 (standard) and the DC/DC converter 2 (optional) step down the voltage from 72 volts to 12 volts for vehicle systems that require 12 volt power, such as exterior lamps, wiper/washer, horn, etc. For diagnosis of the DC/DC converter 2 (optional) or the power point system, refer to [Power Point](#) in this section.

Circuit Schematic

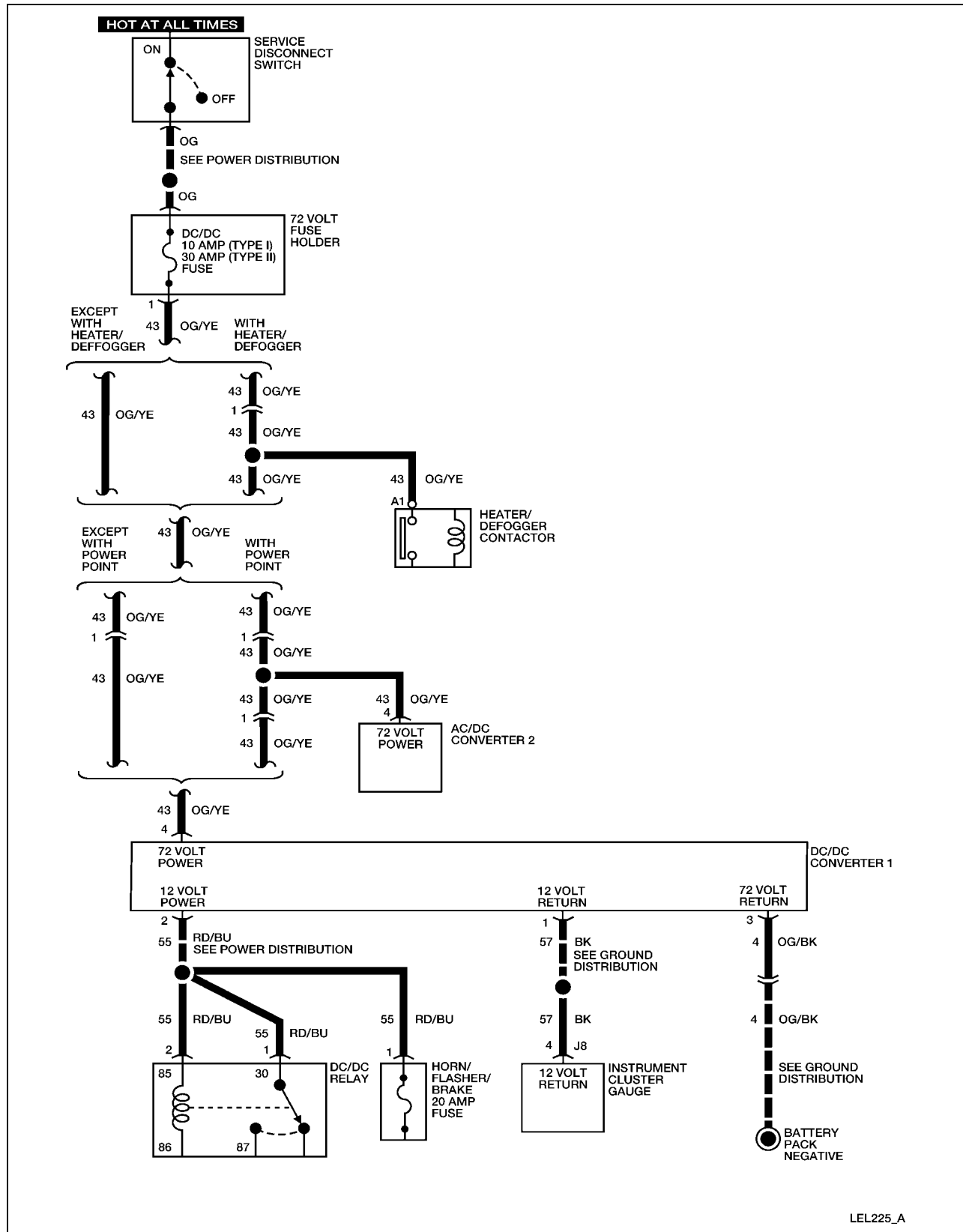

LEL225_A

Required Tools

High Voltage Insulated Gloves	100-F036 or equivalent
Face Shield	100-F035 or equivalent

System Check

Functional components in the voltage step down system are:

- DC/DC converter 1 (standard)
- DC/DC fuse
- Service disconnect switch
- Related wiring

Guidelines to diagnose the voltage step down system:

1. Verify the concern.
2. Check the fuse(s).
3. Check all connectors and related wiring for partially seated terminals, connectors not mating properly and for dirt, moisture or corrosion. For proper contact, terminal(s) must be free of all foreign material.
4. Verify that the battery pack is fully charged. REFER to [Battery](#) in this section.

If the concern still exists, refer to the following table:

Symptom Chart

Symptom	Possible Causes	Action
All 12 volt systems except power point are inoperative	<ul style="list-style-type: none"> • DC/DC fuse • DC/DC converter 1 (standard) • Connectors or related wiring 	GO to DC/DC Converter 1 (Standard) Inoperative.

DC/DC Converter 1 (Standard) Inoperative

WARNING:

THE BATTERY PACK ASSEMBLY CAN DELIVER IN EXCESS OF 72 VOLTS OF DC POWER. IMPROPER HANDLING OF THE BATTERY PACK CAN RESULT IN INJURY OR FATALITY. ONLY AUTHORIZED PERSONNEL TRAINED TO WORK WITH BATTERY PACK COMPONENTS ARE PERMITTED TO HANDLE THE BATTERIES.

WARNING:

THE BATTERY PACK CONTAINS HIGH-VOLTAGE COMPONENTS AND WIRING. HIGH-VOLTAGE INSULATED SAFETY GLOVES AND FACE SHIELD MUST BE WORN WHEN PERFORMING THE FOLLOWING STEPS. FAILURE TO FOLLOW THIS WARNING MAY RESULT IN SEVERE PERSONAL INJURY OR DEATH.

Step	Action	Connector End View
1.	Did you read the Circuit Description and Operation? Yes - GO to Step 2. No - REFER to Circuit Description and Operation in this section.	
2.	Connect a DVOM between the DC/DC converter 1 (standard) harness connector terminal 1 and terminal 2. Does the DVOM display approximately 12 volts? Yes – The DC/DC converter (standard) is operating correctly. CHECK operation of each 12 volt system to determine symptom. No - GO to Step 3.	DC/DC Converter 1 (Standard)
3.	1. Disconnect the DC/DC relay. 2. Remove the Horn/flasher/brake fuse. 3. Connect a DVOM between the DC/DC converter 1 (standard) harness connector terminal 1 and terminal 2. Does the DVOM display approximately 12 volts? Yes – INSTALL a new DC/DC relay. OPERATE the system to verify the repair.	DC/DC Converter 1 (Standard)

Step	Action	Connector End View
	No - GO to Step 4.	
4.	<ol style="list-style-type: none"> 1. Place the service disconnect switch in the OFF position. 2. Disconnect DC/DC converter 1 (standard) harness connector. 3. Connect a DVOM between the DC/DC converter 1 (standard) harness connector terminal 2 and the vehicle chassis. <p>Does continuity exist?</p> <p>Yes – REPAIR circuit 55 (RD/BU). OPERATE the system to verify the repair.</p> <p>No – GO to Step 5.</p>	DC/DC Converter 1 (Standard)
5.	<ol style="list-style-type: none"> 1. Connect a DVOM between the DC/DC converter 1 (standard) harness connector terminal 3 and terminal 4. 2. Place the service disconnect switch in the ON position. <p>Does the DVOM display approximately 72 volts?</p> <p>Yes – INSTALL a new DC/DC converter 1 (standard). REFER to DC/DC Converter 1 (Standard) in this section. OPERATE the system to verify the repair.</p> <p>No – GO to Step 6.</p>	DC/DC Converter 1 (Standard)
6.	<p>Check continuity between the DC/DC converter 1 (standard) harness connector terminal 3 and battery pack negative.</p> <p>Does continuity exist?</p> <p>Yes - REPAIR circuit 43. OPERATE the system to verify the repair.</p> <p>No – REPAIR circuit 4. OPERATE the system to verify the repair.</p>	DC/DC Converter 1 (Standard)

Exterior Lamps

Circuit Description and Operation

The headlamps operate only when the drive mode selector switch is in the Reverse, Turf or Drive position. There are no high beam headlamps on this vehicle. The DC/DC converter 1 (standard) supplies 12 volt power through the DC/DC relay and the lights fuse to the multifunction switch connector-L. When the headlamp switch is turned to the ON (2nd) position, 12 volt power is supplied to the headlamps. The DC/DC converter 1 (standard) supplies 12 volt return for the headlamps to complete the circuit. The flash-to-pass function only operates when the headlamp switch is in the OFF or TAIL (1st) position.

The turn signals operate only when the drive mode selector switch is in the Reverse, Turf or Drive position. When the multifunction switch is in the LH or RH turn signal position, 12 volt power is supplied to the turn signal lamps and to the instrument cluster gauge turn signal indicators. The lamps flash ON and OFF as the electronic flasher internal relay toggles. The DC/DC converter 1 (standard) supplies 12 volt return for the lamps and the instrument cluster gauge to complete the circuit.

The hazard lamps operate with the drive mode selector switch in any position. The DC/DC converter 1 (standard) supplies 12 volt power through the horn/flasher/brake fuse to the multifunction switch connector-L. When the hazard switch (part of multifunction switch) is in the ON position, 12 volt power is supplied to the turn signal lamps and to the instrument cluster gauge turn signal indicators. The lamps and hazard switch will flash ON and OFF continuously until the hazard switch is placed in the OFF position. The DC/DC converter 1 (standard) supplies the 12 volt return for the lamps and the instrument cluster gauge to complete the circuit.

The brake lamps operate with the drive mode selector switch in any position. The center high-mounted stop lamp (CHMSL) is mounted on the rear of the vehicle roof. The CHMSL and the brake lamps illuminate when the brake pedal is depressed. 12 volt power is supplied at all times by the DC/DC converter 1 (standard) to the brake switch through the horn/flasher/brake fuse. The DC/DC converter 1 (standard) supplies 12 volt return for the CHMSL and the brake lamps. When the brake pedal is pressed, the brake switch closes and the brake lamps and CHMSL illuminate.

The reverse lamp illuminates when the drive mode selector switch is turned to the Reverse position. The DC/DC converter 1 (standard) supplies 12 volt return for the reverse lamp. When the drive mode selector switch is turned to the Reverse position, 12 volt power is supplied to the reverse lamp by the instrument cluster gauge and the reverse lamp illuminates.

The taillamps and the license plate lamp illuminate when the drive mode selector switch is turned to the Reverse, Turf or Drive position and the headlamp switch is turned to the TAIL (1st) or ON (2nd) position. When the headlamp switch is turned to the TAIL (1st) or ON (2nd) position, 12 volt power is supplied to the taillamps and the license plate lamp. The DC/DC converter 1 (standard) supplies 12 volt return for the taillamps and the license plate lamp.

Circuit Schematic

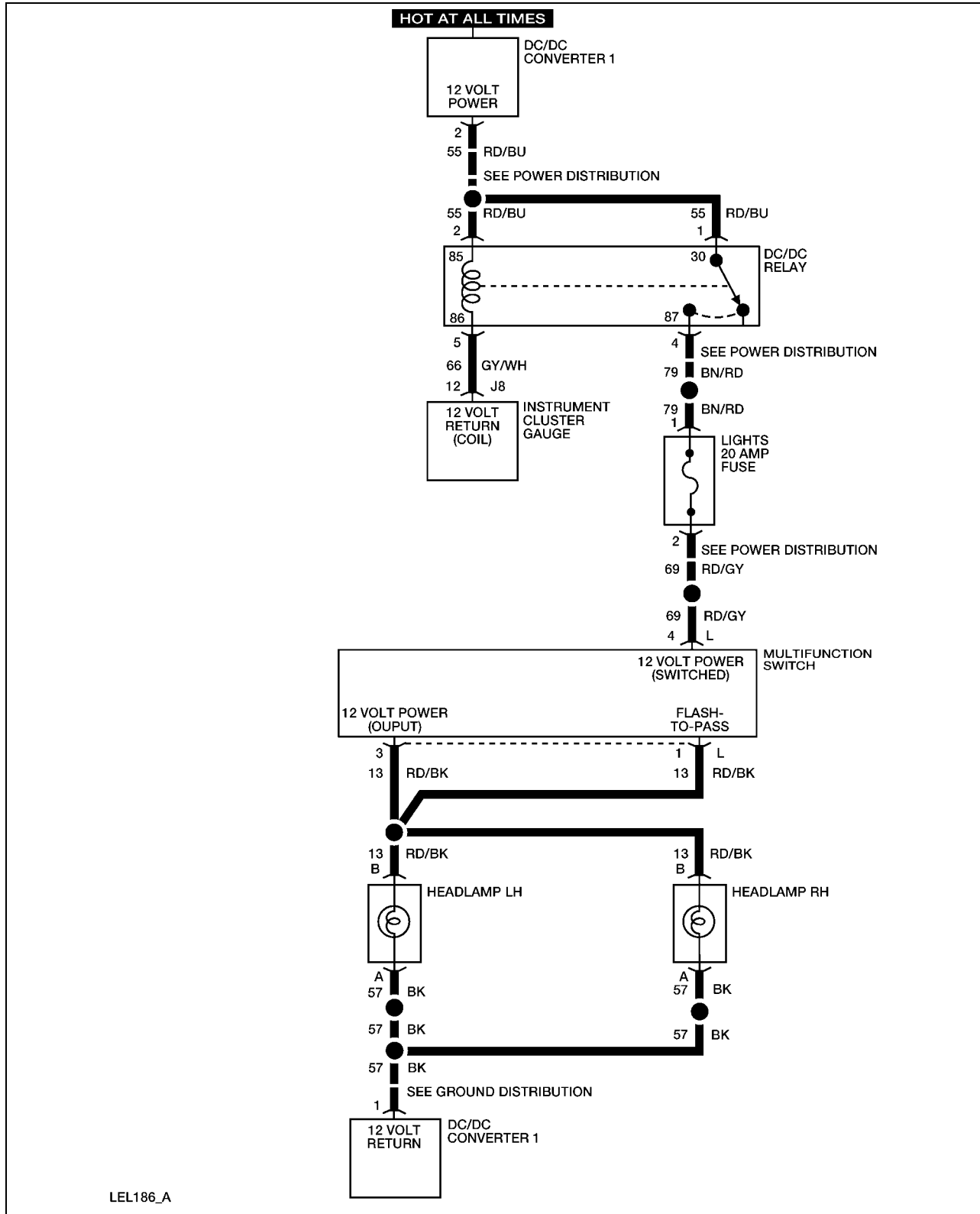

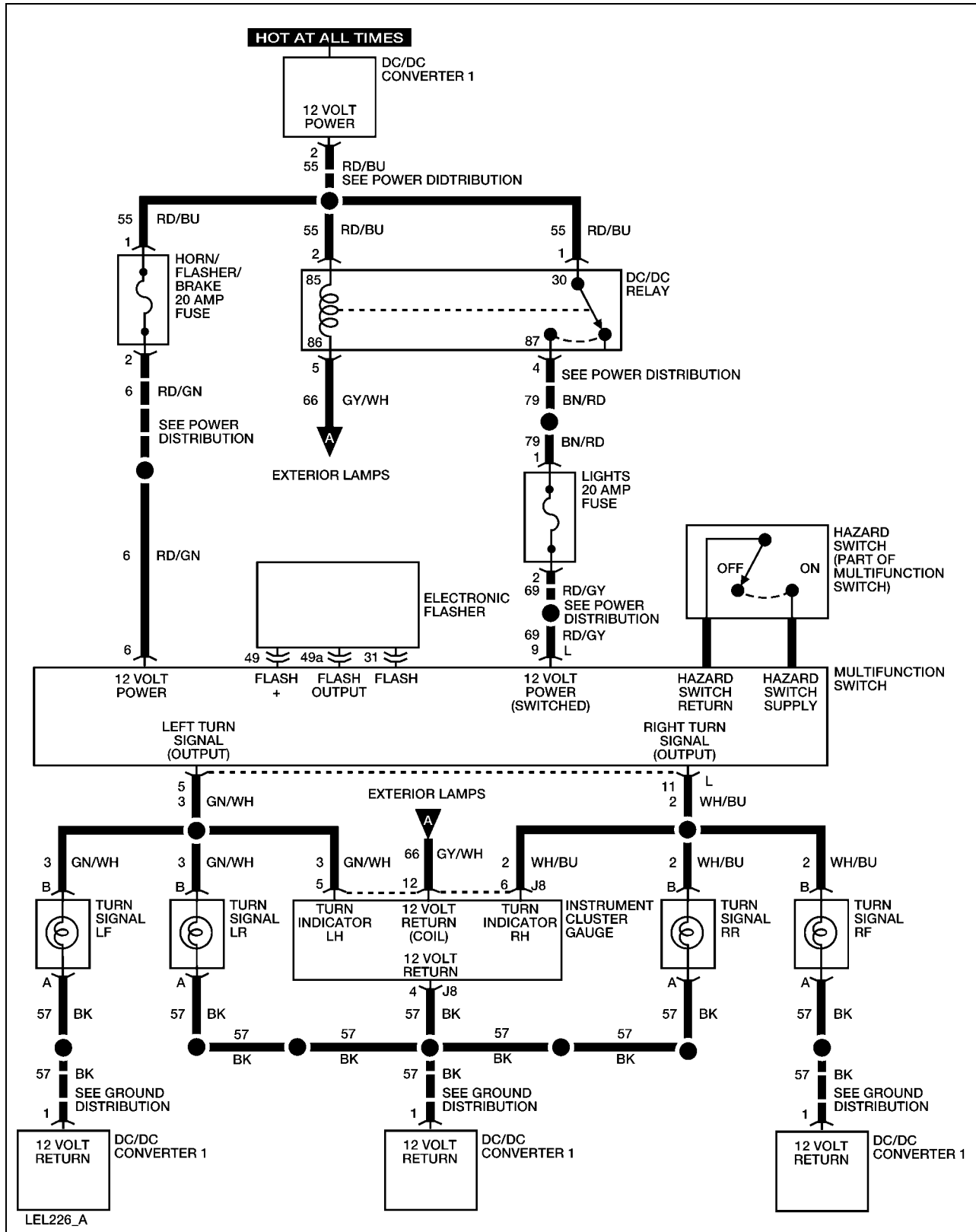

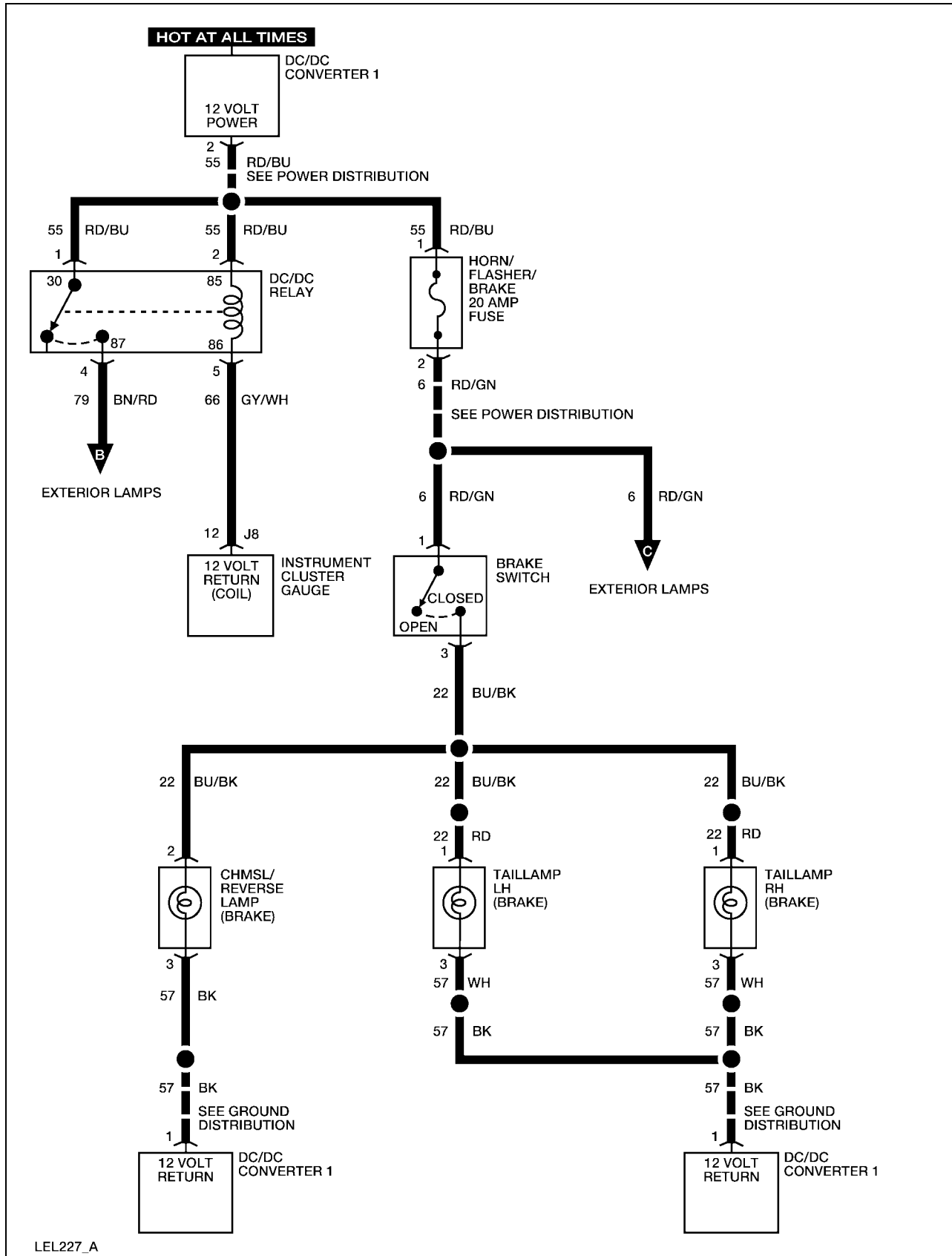

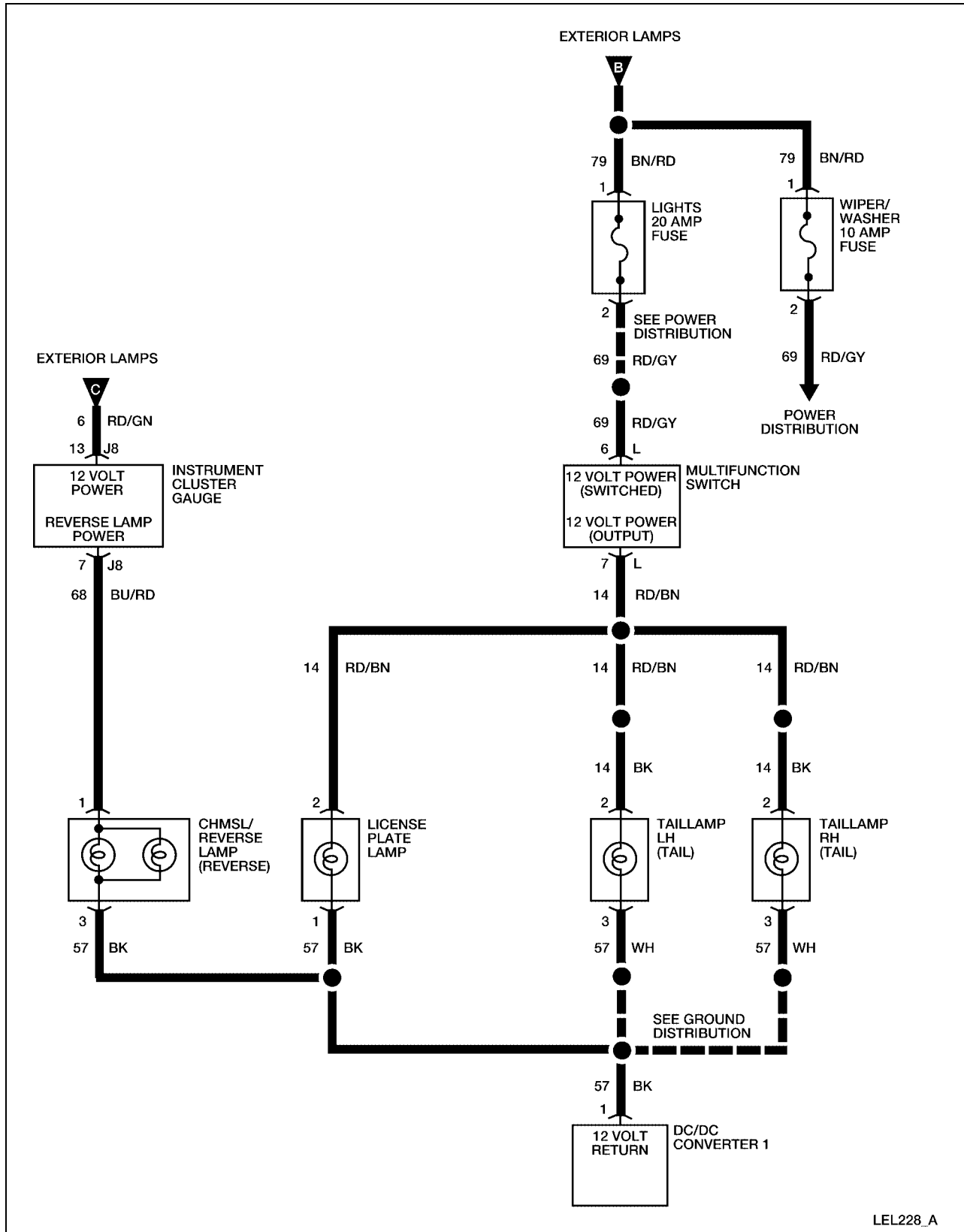

LEL228_A

System Check

Functional components in the exterior lamps system are:

- Lights fuse
- Horn/flasher/brake fuse
- Multifunction switch
- Headlamps
- CHMSL/reverse lamp
- Taillamps
- License plate lamp
- Electronic flasher
- Hazard switch (part of multifunction switch)
- Brake switch
- Turn signal lamps
- Instrument cluster gauge
- Related wiring

Guidelines to diagnose the exterior lamps system:

1. Verify the concern.
2. Check fuse(s).
3. Check all connectors and related wiring for partially seated terminals, connectors not mating properly and for dirt, moisture or corrosion. For proper contact, terminal(s) must be free of all foreign material.
4. If a single lamp is inoperative, check and replace the bulb (if necessary) before performing further diagnosis.

If the concern still exists, refer to the following table:

Symptom Chart

Symptom	Possible Causes	Action
The headlamps are inoperative	<ul style="list-style-type: none"> • Lights fuse • Bulbs • Multifunction switch • Connectors or related wiring 	GO to Headlamps Inoperative.
One headlamp is inoperative	<ul style="list-style-type: none"> • Bulb • Connectors or related wiring 	GO to Headlamps Inoperative — One Lamp.
The headlamps are always on	<ul style="list-style-type: none"> • Multifunction switch • Connectors or related wiring 	GO to Headlamp(s) Always ON.
The turn signal lamps are inoperative	<ul style="list-style-type: none"> • Lights fuse • Horn/flasher/brake fuse • Bulbs • Multifunction switch • Connectors or related wiring 	GO to Turn Signal Lamps Inoperative.
One turn signal lamp is inoperative	<ul style="list-style-type: none"> • Bulb • Connectors or related wiring 	GO to Turn Signal Lamps Inoperative — Left or Right Side.
The turn signal lamps are inoperative — left or right side	<ul style="list-style-type: none"> • Bulbs • Connectors or related wiring 	GO to Turn Signal Lamps Inoperative — Left or Right Side.
The turn signal indicator is inoperative — left or right side	<ul style="list-style-type: none"> • Instrument cluster gauge • Connectors or related wiring 	GO to Turn Signal Indicator Inoperative — Left or Right Side

Symptom	Possible Causes	Action
The hazard flasher is inoperative (turn signals operate correctly)	<ul style="list-style-type: none"> • Multifunction switch 	INSTALL a new multifunction switch. REFER to Multifunction Switch in this section. OPERATE the system to verify the repair.
The hazard flasher switch illumination is inoperative	<ul style="list-style-type: none"> • Bulb 	INSTALL a new hazard flasher switch bulb. OPERATE the system to verify the repair.
The hazard flasher is always on	<ul style="list-style-type: none"> • Multifunction switch 	INSTALL a new multifunction switch. REFER to Multifunction Switch in this section. OPERATE the system to verify the repair.
The brake lamps are inoperative	<ul style="list-style-type: none"> • Horn/flasher/brake fuse • Brake switch • Connectors or related wiring 	GO to Brake Lamps Inoperative.
One brake lamp is inoperative — left or right side	<ul style="list-style-type: none"> • Bulb • Connectors or related wiring 	GO to One Brake Lamp Inoperative — Left or Right Side.
The CHMSL is inoperative	<ul style="list-style-type: none"> • Bulb • Connectors or related wiring 	GO to CHMSL Inoperative.
The brake lamps/CHMSL is always on	<ul style="list-style-type: none"> • Brake switch • Connectors or related wiring 	GO to Brake Lamps/CHMSL Always ON.
The reverse lamps are inoperative	<ul style="list-style-type: none"> • Instrument cluster gauge • Connectors or related wiring 	GO to Reverse Lamps Inoperative.
The reverse lamps are always on	<ul style="list-style-type: none"> • Instrument cluster gauge • Connectors or related wiring 	GO to Reverse Lamps Always ON.

Symptom	Possible Causes	Action
The taillamps/license plate lamps are inoperative	<ul style="list-style-type: none"> Lights fuse Multifunction switch Connectors or related wiring 	GO to Tail/License Plate Lamps Inoperative.
One taillamp is inoperative	<ul style="list-style-type: none"> Bulb Connectors or related wiring 	GO to One Tail/License Lamp Inoperative.
The license plate lamp is inoperative	<ul style="list-style-type: none"> Bulb Connectors or related wiring 	GO to One Tail/License Lamp Inoperative.
The taillamps/license plate lamps are always on	<ul style="list-style-type: none"> Multifunction switch Connectors or related wiring 	GO to Tail/License Plate Lamps Always On.

Headlamps Inoperative

Step	Action	Connector End View
1	<p>Did you read the Circuit Description and Operation?</p> <p>Yes – GO to Step 2.</p> <p>No – REFER to Circuit Description and Operation.</p>	
2	<ol style="list-style-type: none"> Set the park brake. Place the drive mode selector switch in the Reverse, Turf or Drive position. Operate the flash-to-pass switch. <p>Do the headlamps illuminate?</p> <p>Yes – GO to Step 3.</p> <p>No – INSTALL a new multifunction switch. REFER to Multifunction Switch in this section. OPERATE the system to verify the repair.</p>	
3	<ol style="list-style-type: none"> Connect a DVOM between multifunction switch connector-L terminal 3 and the vehicle chassis. Place the headlamp switch in the ON (2nd) position. 	Multifunction Switch-L

Step	Action	Connector End View
	<p>Does the DVOM display approximately 12 volts?</p> <p>Yes – REPAIR circuit 13. OPERATE the system to verify the repair.</p> <p>No – INSTALL a new multifunction switch. REFER to Multifunction Switch in this section. OPERATE the system to verify the repair.</p>	

Headlamps Inoperative — One Lamp

Step	Action	Connector End View
1	<p>Did you read the Circuit Description and Operation?</p> <p>Yes – GO to Step 2.</p> <p>No – REFER to Circuit Description and Operation.</p>	
2	<ol style="list-style-type: none"> 1. Disconnect the inoperative headlamp. 2. Set the park brake. 3. Place the drive mode selector switch in the Reverse, Turf or Drive position. 4. Place the headlamp switch in the ON (2nd) position. 5. Connect a DVOM between the inoperative headlamp connector terminal A and terminal B. <p>Does the DVOM display approximately 12 volts?</p> <p>Yes – INSTALL a new headlamp bulb. REFER to Headlamp Bulb. OPERATE the system to verify the repair.</p> <p>No – REPAIR circuit 13. OPERATE the system to verify the repair.</p>	<p>Headlamp LH</p> <p>Headlamp RH</p>

Headlamp(s) Always ON

Step	Action	Connector End View
1	Did you read the Circuit Description and Operation? Yes – GO to Step 2. No – REFER to Circuit Description and Operation .	
2	Disconnect the multifunction switch connector-L. Do the headlamps illuminate? Yes – REPAIR circuit 13 between the multifunction switch harness connector-L terminal 1 or terminal 3 and the headlamps. OPERATE the system to verify the repair. No – INSTALL a new multifunction switch. REFER to Multifunction Switch in this section. OPERATE the system to verify the repair.	Multifunction Switch-L

Turn Signal Lamps Inoperative

Step	Action	Connector End View
1	Did you read the Circuit Description and Operation? Yes - GO to Step 2. No – REFER to Circuit Description and Operation .	
2	Place the hazard switch in the ON position. Do the hazard lamps operate correctly? Yes - INSTALL a new multifunction switch. REFER to Multifunction Switch in this section. OPERATE the system to verify the repair. No - GO to Step 3.	
3	1. Disconnect the electronic flasher. 2. Connect a fused jumper wire between the electronic flasher connector terminal 49a and terminal 49. 3. Turn on the left turn signals. Do all left turn signals illuminate? Yes – INSTALL a new electronic flasher. REFER to Electronic	

Step	Action	Connector End View
	<p>Flasher in this section. OPERATE the system to verify the repair.</p> <p>No – INSTALL a new multifunction switch. REFER to Multifunction Switch in this section. OPERATE the system to verify the repair.</p>	

Turn Signal Lamps Inoperative — Left or Right Side

Step	Action	Connector End View
1	<p>Did you read the Circuit Description and Operation?</p> <p>Yes - GO to Step 2.</p> <p>No - REFER to Circuit Description and Operation.</p>	
2	<ol style="list-style-type: none"> 1. Disconnect an inoperative turn signal lamp. 2. Set the park brake. 3. Place the drive mode selector switch in the Reverse, Turf or Drive position. 4. Place the turn signal switch in the ON position (inoperative side). 5. Connect a DVOM between the inoperative turn signal lamp connector terminal A and terminal B. <p>Does the DVOM display approximately 12 volts?</p> <p>Yes – INSTALL a new bulb. OPERATE the system to verify the repair.</p> <p>No – GO to Step 3.</p>	<p>Turn Signal LF</p> <p>Turn Signal RF</p> <p>Turn Signal LR</p> <p>Turn Signal RR</p>
3	<p>Connect a DVOM between multifunction switch terminal 5 (LH side) or terminal 11 (RH side) and inoperative turn signal lamps.</p> <p>Does continuity exist?</p> <p>Yes – INSTALL a new multifunction switch. REFER to Multifunction Switch in this section. OPERATE the system to verify the repair.</p> <p>No - REPAIR circuit 2 (RH side) or circuit 3 (LH side). OPERATE the system to verify the repair.</p>	<p>Multifunction Switch-L</p>

Turn Signal Indicator Inoperative — Left or Right Side

Step	Action	Connector End View
1	<p>Did you read the Circuit Description and Operation?</p> <p>Yes - GO to Step 2.</p> <p>No - REFER to Circuit Description and Operation.</p>	
2	<ol style="list-style-type: none"> 1. Disconnect instrument cluster gauge connector J8. 2. Set the park brake. 3. Place the drive mode selector switch in the Reverse, Turf or Drive position. 4. Place the turn signal switch in the ON position (inoperative side). 5. Connect a DVOM between instrument cluster connector J8 terminal 5 (LH side) or terminal 6 (RH side) and terminal 4. <p>Does the DVOM display approximately 12 volts?</p> <p>Yes – INSTALL a new instrument cluster gauge. REFER to Instrument Cluster Gauge in this section. OPERATE the system to verify the repair.</p> <p>No - REPAIR circuit 5 (LH side) or circuit 6 (RH side). OPERATE the system to verify the repair.</p>	Instrument Cluster Gauge – J8

Brake Lamps Inoperative

Step	Action	Connector End View
1	<p>Did you read the Circuit Description and Operation?</p> <p>Yes - GO to Step 2.</p> <p>No - REFER to Circuit Description and Operation.</p>	
2	<ol style="list-style-type: none"> 1. Disconnect the brake switch harness connector. 2. Connect a fused jumper wire between the brake switch connector terminal 1 and terminal 3. <p>Do the brake lamps illuminate?</p> <p>Yes - INSTALL a new brake switch. OPERATE the system to verify the repair.</p> <p>No - REPAIR circuit 22. OPERATE the system to verify the repair.</p>	Brake Switch

One Brake Lamp Inoperative — Left or Right Side

Step	Action	Connector End View
1	<p>Did you read the Circuit Description and Operation?</p> <p>Yes - GO to Step 2.</p> <p>No - REFER to Circuit Description and Operation.</p>	
2	<ol style="list-style-type: none"> 1. Disconnect the harness connector of the inoperative brake lamp. 2. Connect a DVOM between terminal 1 (taillamp LH or RH harness connector) or terminal 2 (CHMSL/reverse lamp harness connector) and terminal 3 of the inoperative brake lamp. 3. Press the brake pedal. <p>Does the DVOM display approximately 12 volts?</p> <p>Yes – INSTALL a new bulb. OPERATE the system to verify the repair.</p> <p>No - REPAIR circuit 22. OPERATE the system to verify the repair.</p>	<p>Taillamp LH</p> <p>Taillamp RH</p> <p>CHMSL/Reverse Lamp</p>

CHMSL Inoperative

Step	Action	Connector End View
1	<p>Did you read the Circuit Description and Operation?</p> <p>Yes - GO to Step 2.</p> <p>No - REFER to Circuit Description and Operation.</p>	
2	<ol style="list-style-type: none"> 1. Disconnect the CHMSL/reverse lamp harness connector. 2. Connect a DVOM between CHMSL/reverse lamp harness connector terminal 2 and terminal 3. 3. Press the brake pedal. <p>Does the DVOM display approximately 12 volts?</p> <p>Yes – INSTALL a new bulb. OPERATE the system to verify the repair.</p> <p>No - REPAIR circuit 22. OPERATE the system to verify the repair.</p>	<p>CHMSL/Reverse Lamp</p>

Brake Lamps/CHMSL Always ON

Step	Action	Connector End View
1	Did you read the Circuit Description and Operation? Yes - GO to Step 2. No - REFER to Circuit Description and Operation .	
2	Disconnect the brake switch harness connector. Do the brake lamps and CHMSL remain illuminated? Yes - REPAIR circuit 22. OPERATE the system to verify the repair. No - INSTALL a new brake switch. OPERATE the system to verify the repair.	Brake Switch

Reverse Lamps Inoperative

Step	Action	Connector End View
1	Did you read the Circuit Description and Operation? Yes - GO to Step 2. No - REFER to Circuit Description and Operation .	
2	1. Disconnect the CHMSL/reverse lamp harness connector. 2. Connect a DVOM between CHMSL/reverse lamp harness connector terminal 1 and terminal 3. 3. Set the park brake. 4. Place the drive mode selector switch in the Reverse position. Does the DVOM display approximately 12 volts? Yes - INSTALL new bulbs. OPERATE the system to verify the repair. No - GO to Step 3.	CHMSL/Reverse Lamp
3	Connect a DVOM between instrument cluster gauge connector J8 terminal 7 and the CHMSL/reverse lamp connector terminal 1. Does continuity exist? Yes - INSTALL a new instrument cluster gauge. REFER to Instrument Cluster Gauge in this section. OPERATE the	

Step	Action	Connector End View
	<p>system to verify the repair.</p> <p>No – REPAIR circuit 68. OPERATE the system to verify the repair.</p>	

Reverse Lamps Always ON

Step	Action	Connector End View
1	<p>Did you read the Circuit Description and Operation?</p> <p>Yes - GO to Step 2.</p> <p>No - REFER to Circuit Description and Operation.</p>	
2	<p>1. Disconnect instrument cluster gauge harness connector J8.</p> <p>2. Set the park brake.</p> <p>3. Place the drive mode selector switch in the Drive position.</p> <p>Do the reverse lamps remain illuminated?</p> <p>Yes - REPAIR circuit 68. OPERATE the system to verify the REPAIR.</p> <p>No – INSTALL a new instrument cluster gauge. REFER to Instrument Cluster Gauge in this section. OPERATE the system to verify the repair.</p>	

Tail/License Plate Lamps Inoperative

Step	Action	Connector End View
1	<p>Did you read the Circuit Description and Operation?</p> <p>Yes - GO to Step 2.</p> <p>No - REFER to Circuit Description and Operation.</p>	
2	<p>Press the brake pedal.</p> <p>Do the brake lamps illuminate?</p> <p>Yes – GO to Step 3.</p> <p>No – REFER to Brake Lamps Inoperative.</p>	
3	<p>1. Connect a DVOM between multifunction switch harness connector-L terminal 6 and terminal 7.</p>	Multifunction Switch-L

Step	Action	Connector End View
	<p>2. Set the park brake.</p> <p>3. Place the drive mode selector switch in the Reverse, Turf or Drive position.</p> <p>4. Place the headlamp switch in the TAIL (1st) position.</p> <p>Does the DVOM display approximately 12 volts?</p> <p>Yes – REPAIR circuit 14. OPERATE the system to verify the repair.</p> <p>No – INSTALL a new multifunction switch. REFER to Multifunction Switch in this section. OPERATE the system to verify the repair.</p>	

One Tail/License Lamp Inoperative

Step	Action	Connector End View
1	<p>Did you read the Circuit Description and Operation?</p> <p>Yes - GO to Step 2.</p> <p>No - REFER to Circuit Description and Operation.</p>	
2	<p>1. Disconnect the inoperative taillamp harness connector.</p> <p>2. Set the park brake.</p> <p>3. Place the drive mode selector switch in the Reverse, Turf or Drive position.</p> <p>4. Place the headlamp switch in the TAIL (1st) position.</p> <p>5. Connect a DVOM between the inoperative taillamp harness connector terminal 2 and terminal 3 (LH or RH taillamp) or terminal 1 (license plate lamp).</p> <p>Does the DVOM display approximately 12 volts?</p> <p>Yes – INSTALL a new bulb. OPERATE the system to verify the repair.</p> <p>No – REPAIR circuit 14. OPERATE the system to verify the repair.</p>	<p>Taillamp LH</p> <p>Taillamp RH</p> <p>License Plate Lamp</p>

Tail/License Plate Lamps Always On

Step	Action	Connector End View
1	Did you read the Circuit Description and Operation? Yes - GO to Step 2. No - REFER to Circuit Description and Operation .	
2	Disconnect the multifunction switch harness connector-L. Are the taillamps and license plate lamp illuminated? Yes - REPAIR circuit 14. OPERATE the system to verify the repair. No - INSTALL a new multifunction switch. REFER to Multifunction Switch in this section. OPERATE the system to verify the repair.	Multifunction Switch – L

Heater/Defogger

Circuit Description and Operation

The heater/defogger system consists of an electromechanical switch mounted on the cowl, heater element, fan, and contactor that are mounted on a bracket under the cowl, and two jumper harnesses which connect to the main harness and deliver power to the system. Two air vent hoses route warm air from the heater box to air ducts mounted on the right and left sides of the cowl.

The system cannot be operated unless the vehicle is powered on (charging cord is disconnected, service disconnect switch is ON, and drive mode selector switch is in reverse, turf, or drive). When the heater switch is turned on, a microprocessor in the switch closes a relay in the contactor to turn the system on. The switch has a built-in timer that will turn the system off after 10 minutes. The switch may also be turned off any time during the 10-minute run cycle.

There are two jumper harnesses used on the heater/defogger. The 18A654 jumper harness delivers 72V from the main harness through the contactor mounted on the heater box to the heater element, then continuing through the DC/DC converter. The 18A586 jumper harness delivers 12V, when the vehicle is powered on and the drive mode selector switch is on, to close the contactor and power the heater fan. The connector that connects the DC/DC converter to this jumper harness is included on every vehicle. On vehicles without heater/defogger, this connector may be used to provide power to aftermarket accessories such as lights, radio, etc. at the discretion of the customer.

Using the heater/defogger for the full 10-minute cycle will consume approximately 25% of the capacity of a completely charged battery pack.

Circuit Schematic

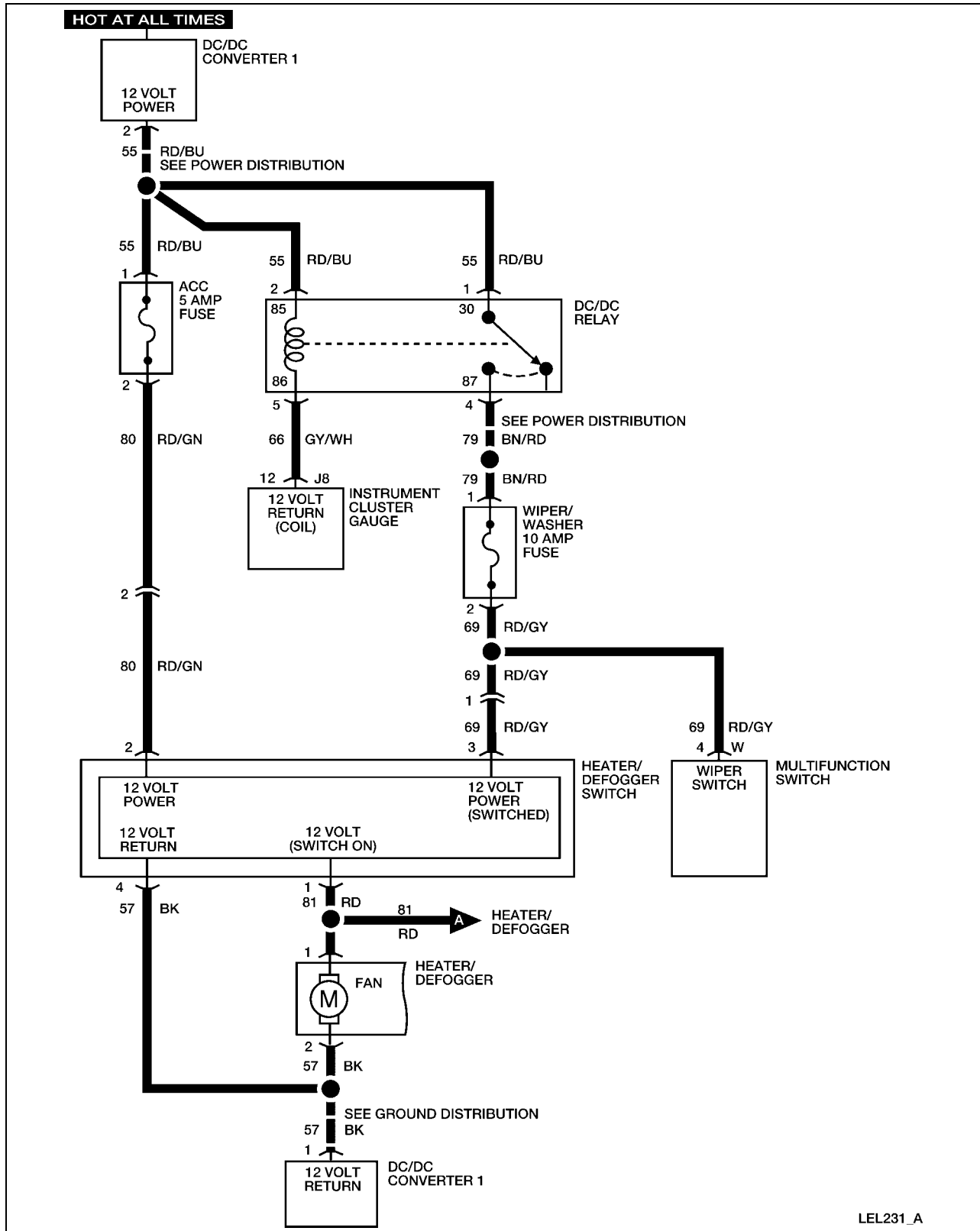

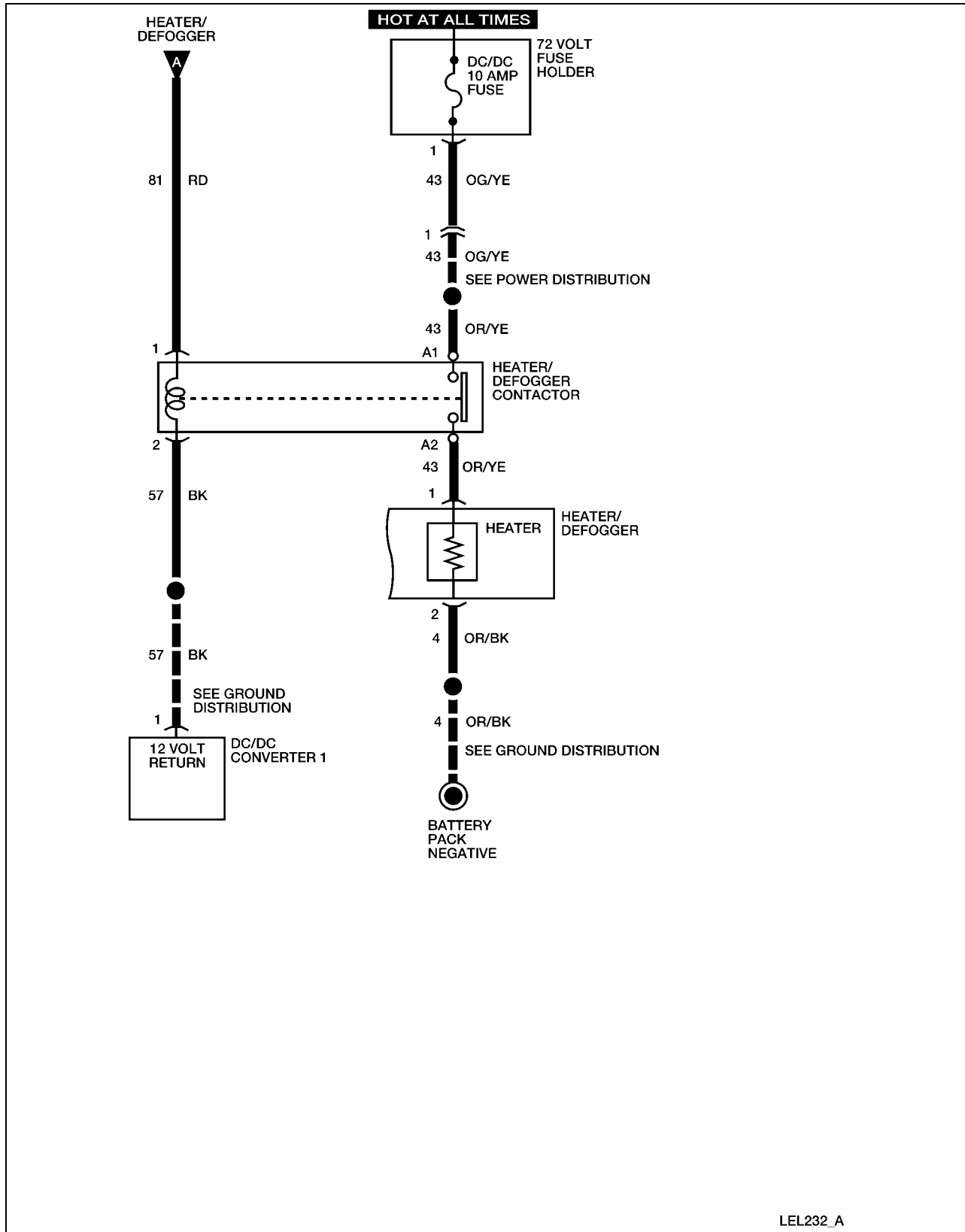

LEL232_A

System Check

Functional components in the heater/defogger system are:

- Lamps fuse
- ACC fuse
- Heater/defogger switch
- DC/DC relay
- Heater blower control relay
- Heater
- Fan
- Vent hose
- Nylon clamps
- Related wiring

Guidelines to diagnose the heater/defogger system:

1. Verify the concern.
2. Check fuse(s).
3. Check all connectors and related wiring for partially seated terminals, connectors not mating properly and for dirt, moisture or corrosion. For proper contact, terminal(s) must be free of all foreign material.

If the concern still exists, refer to the following table:

Symptom Chart

Symptom	Possible Causes	Action
The fan is inoperative	<ul style="list-style-type: none"> • Lamps fuse • DC/DC relay • Heater/defogger switch • Fan • Connectors or related wiring 	GO to Fan Inoperative .
The fan is always on	<ul style="list-style-type: none"> • Heater/defogger switch • Connectors or related wiring 	GO to Fan Always ON .
The fan runs but blows cool air	<ul style="list-style-type: none"> • Heater blower control relay • Heater • Heater/defogger contactor • Connectors or related wiring 	GO to Heater Inoperative .
The fan runs but no air is directed to the windshield	<ul style="list-style-type: none"> • Heater/defogger ducts • Nylon clamps • Vent hose 	INSPECT vent hoses for damage, incorrect routing or for loose connection to ducts. INSPECT nylon clamps for incorrect installation. REPAIR as necessary.
The fan runs but air is directed to only one side of the windshield	<ul style="list-style-type: none"> • Heater/defogger ducts • Nylon clamps • Vent hose 	INSPECT vent hoses for damage, incorrect routing or for loose connection to ducts. INSPECT nylon clamps for incorrect installation. REPAIR as necessary.
The fan runs but air volume is low	<ul style="list-style-type: none"> • Heater/defogger ducts • Nylon clamps • Vent hose 	INSPECT vent hoses for damage, incorrect routing or for loose connection to ducts. INSPECT nylon clamps for incorrect installation. REPAIR as necessary.

Fan Inoperative

Step	Action	Connector End View
1.	<p>Did you read the Circuit Description and Operation?</p> <p>Yes – GO to Step 2.</p> <p>No – REFER to Circuit Description and Operation.</p>	
2.	<p>1. Place the drive mode selector switch in the Reverse, Turf or Drive position.</p> <p>2. Press the heater/defogger switch to turn the system on.</p> <p>Does the heater/defogger switch illuminate?</p> <p>Yes – GO to Step 3.</p> <p>No – GO to Step 6.</p>	
3.	<p>1. Disconnect the fan connector.</p> <p>2. Connect a DVOM between fan connector terminal 1 and the vehicle chassis.</p> <p>Press the heater/defogger switch to turn the system on.</p> <p>Does the DVOM display approximately 12 volts?</p> <p>Yes – GO to Step 4.</p> <p>No – GO to Step 5.</p>	Heater/defogger Fan
4.	<p>Connect a DVOM between fan connector terminal 2 and the vehicle chassis.</p> <p>Does continuity exist?</p> <p>Yes – INSTALL a new fan. OPERATE the system to verify the repair.</p> <p>No – REPAIR circuit 57 (BK). OPERATE the system to verify the repair.</p>	Heater/defogger Fan

5.	<p>1. Disconnect heater/defogger switch connector.</p> <p>2. Connect a DVOM between fan connector terminal 1 and heater/defogger switch connector terminal 1.</p> <p>Does continuity exist?</p> <p>Yes – INSTALL a new heater/defogger switch. OPERATE the system to verify the repair.</p> <p>No – REPAIR circuit 81 (RD). OPERATE the system to verify the repair.</p>	<p>Heater/defogger Fan</p> <p>Heater/defogger Switch</p>
6.	<p>1. Disconnect the heater/defogger switch connector.</p> <p>2. Connect a DVOM between heater/defogger switch terminal 2 and the vehicle chassis, and between heater/defogger switch terminal 3 and the vehicle chassis.</p> <p>Does the DVOM display approximately 12 volts?</p> <p>Yes – REPAIR circuit 57 (BK). OPERATE the system to verify the repair.</p> <p>No – REPAIR circuit 80 (RD/GN) or circuit 69 (RD/GY). OPERATE the system to verify the repair.</p>	<p>Heater/defogger Switch</p>

Fan Always ON

Step	Action	Connector End View
1	<p>Did you read the Circuit Description and Operation?</p> <p>Yes – GO to Step 2.</p> <p>No – REFER to Circuit Description and Operation.</p>	

Step	Action	Connector End View
2	1. Disconnect the heater/defogger switch. 2. Place the drive mode selector switch in the reverse, turf or drive position. 3. Check operation of the fan. Does the fan still run? Yes – REPAIR circuit 81 (RD). OPERATE the system to verify the repair. No – INSTALL a new heater/defogger switch. OPERATE the system to verify the repair.	

Heater Inoperative

Step	Action	Connector End View
1	Did you read the Circuit Description and Operation? Yes – GO to Step 2. No – REFER to Circuit Description and Operation .	
2	1. Place the drive mode selector switch in the Reverse, Turf or Drive position. 2. Press the heater/defogger switch to turn the system on while listening for noise from the heater/defogger contactor. Does the heater/defogger contactor click when the system is turned on? Yes – GO to Step 3. No – GO to Step 7.	
3	1. Disconnect the heater/defogger contactor. 2. Connect a DVOM between heater/defogger contactor terminal A1 and the vehicle chassis. Does the DVOM display approximately 72 volts?	Heater/defogger Contactor

Step	Action	Connector End View
	<p>Yes – GO to Step 4.</p> <p>No – REPAIR circuit 43 (OR/YE) between the 72 volt fuse holder and the heater/defogger contactor. OPERATE the system to verify the repair.</p>	
4	<p>Connect a DVOM between heater/defogger contactor terminal A2 and the vehicle chassis.</p> <p>Does continuity exist?</p> <p>Yes – INSTALL a new heater/defogger contactor. REFER to Heater/Defogger System in this section. OPERATE the system to verify the repair.</p> <p>No – GO to Step 5.</p>	<p>Heater/defogger Contactor</p>
5	<ol style="list-style-type: none"> 1. Disconnect the heater/defogger. 2. Connect a DVOM between heater/defogger contactor terminal A2 and heater/defogger terminal 1. <p>Does continuity exist?</p> <p>Yes – GO to Step 6.</p> <p>No – REPAIR circuit 43 (OR/YE) between the heater/defogger contactor and the heater/defogger. OPERATE the system to verify the repair.</p>	<p>Heater/defogger Contactor</p> <p>Heater/defogger</p>
6	<p>Connect a DVOM between heater/defogger terminal 2 and the vehicle chassis.</p> <p>Does continuity exist?</p> <p>Yes – INSTALL a new heater/defogger. REFER to Heater/Defogger Assembly in this section. OPERATE the system to verify the repair.</p> <p>No – REPAIR circuit 4 (OR/BK). OPERATE the system to verify the repair.</p>	<p>Heater/defogger</p>
7	<ol style="list-style-type: none"> 1. Disconnect the heater/defogger contactor. 2. Connect a DVOM between heater/defogger contactor terminal 1 and the vehicle chassis. 	<p>Heater/defogger Contactor</p>

Step	Action	Connector End View
	<p>Does the DVOM display approximately 12 volts?</p> <p>Yes – GO to Step 8.</p> <p>No – REPAIR circuit 81 (RD). OPERATE the system to verify the repair.</p>	
8	<p>Connect a DVOM between heater/defogger terminal 2 and the vehicle chassis.</p> <p>Does continuity exist?</p> <p>Yes – INSTALL a new heater/defogger contactor. REFER to Heater/Defogger System in this section. OPERATE the system to verify the repair.</p> <p>No – REPAIR circuit 57 (RD). OPERATE the system to verify the repair.</p>	Heater/defogger

Horn

Circuit Description and Operation

The horn will sound any time the horn switch is pressed. The DC/DC converter 1 (standard) supplies 12 volt power through the horn/flasher/brake fuse to the multifunction switch and the horn. When the horn switch is pressed, 12 volt power is supplied to the horn relay coil, which closes the horn relay switch, providing a 12 volt return for the horn. This completes the circuit and the horn will sound.

Circuit Schematic

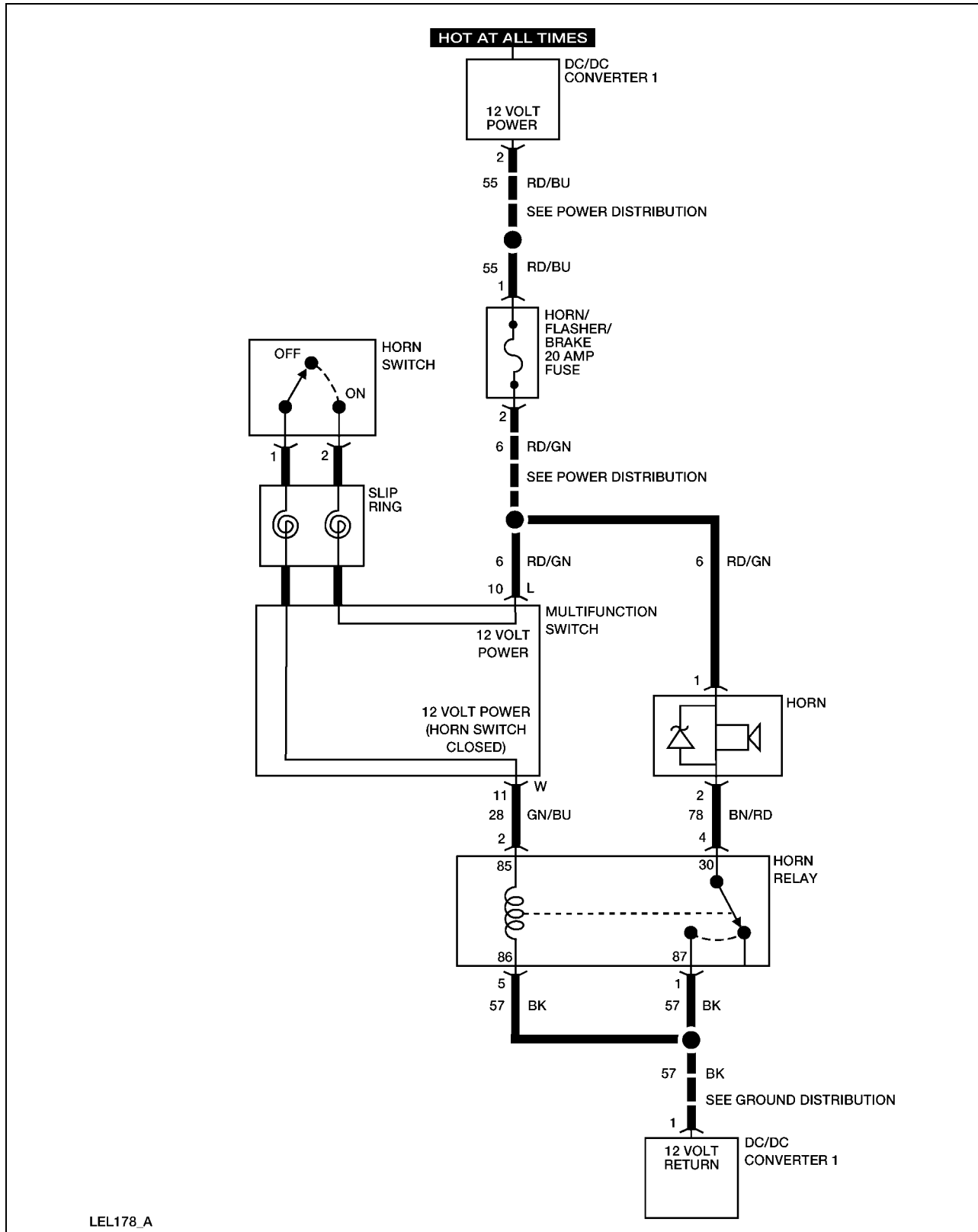

LEL178_A

System Check

Functional components in the horn system are:

- Horn/flasher/brake fuse
- Horn switch
- Multifunction switch
- Horn
- Horn relay
- Related wiring

Guidelines to diagnose the horn system:

1. Verify the concern.
2. Check the fuse(s).
3. Check all connectors and related wiring for partially seated terminals, connectors not mating properly and for dirt, moisture or corrosion. For proper contact, terminal(s) must be free of all foreign material.

If the concern still exists, refer to the following table:

Symptom Chart

Symptom	Possible Causes	Action
The horn is inoperative	<ul style="list-style-type: none"> • Horn/flasher/brake fuse • Horn Relay • Horn • Horn switch • Multifunction switch • Connectors or related wiring 	GO to Horn Inoperative.
The horn is always on	<ul style="list-style-type: none"> • Horn relay • Multifunction switch • Horn switch 	GO to Horn Always On.

Symptom	Possible Causes	Action
	<ul style="list-style-type: none"> Connectors or related wiring 	

Horn Inoperative

Step	Action	Connector End View
1	<p>Did you read the Circuit Description and Operation?</p> <p>Yes – GO to Step 2.</p> <p>No – REFER to Circuit Description and Operation.</p>	
2	<p>Place the hazard switch in the ON position.</p> <p>Do the hazard lamps operate properly?</p> <p>Yes – GO to Step 3.</p> <p>No – REFER to DC/DC Converter 1 (Standard) Inoperative.</p>	
3	<ol style="list-style-type: none"> Disconnect the horn relay harness connector. Connect a DVOM between the horn relay harness connector terminal 2 and the vehicle chassis. Press the horn switch. <p>Does the DVOM display approximately 12 volts?</p> <p>Yes – GO to Step 4.</p> <p>No – GO to Step 8.</p>	Horn Relay
4	<p>Connect a DVOM between the horn relay harness connector terminal 4 and the vehicle chassis.</p> <p>Does the DVOM display approximately 12 volts?</p> <p>Yes – GO to Step 5.</p> <p>No – GO to Step 6.</p>	Horn Relay
5	<ol style="list-style-type: none"> Check continuity between the horn relay harness connector terminal 1 and the vehicle chassis. Check continuity between the horn relay harness connector terminal 5 and the vehicle chassis. <p>Does continuity exist?</p> <p>Yes – INSTALL a new horn relay. OPERATE the system to verify the repair.</p>	Horn Relay

Step	Action	Connector End View
	No – REPAIR circuit 57. OPERATE the system to verify the repair.	
6	1. Disconnect the horn harness connector. 2. Connect a DVOM between the horn harness connector terminal 1 and the vehicle chassis. Does the DVOM display approximately 12 volts? Yes – GO to Step 7. No – REPAIR circuit 6. OPERATE the system to verify the repair.	Horn
7	Check continuity between the horn harness connector terminal 2 and the horn relay harness connector terminal 4. Does continuity exist? Yes – INSTALL a new horn. OPERATE the system to verify the repair. No – REPAIR circuit 78. OPERATE the system to verify the repair.	Horn Horn Relay
8	1. Disconnect the multifunction switch harness connectors. 2. Connect a DVOM between the multifunction switch harness connector L terminal 10 and the vehicle chassis. Does the DVOM display approximately 12 volts? Yes – GO to Step 9. No - REPAIR circuit 6. OPERATE the system to verify the repair.	Multifunction Switch - L
9	Check continuity between the multifunction switch harness connector W terminal 11 and the horn relay harness connector terminal 2. Does continuity exist? Yes – GO to Step 10. No – REPAIR circuit 28. OPERATE the system to verify the repair.	Multifunction Switch - W Horn Relay

Step	Action	Connector End View
10	<p>1. Disconnect the horn switch harness connector.</p> <p>2. Check continuity between the horn switch harness connector terminal 1 and the multifunction switch harness connector W terminal 11.</p> <p>3. Check continuity between the horn switch harness connector terminal 2 and the multifunction switch harness connector L terminal 10.</p> <p>Does continuity exist?</p> <p>Yes – INSTALL a new horn switch. REFER to Horn Switch in this section. OPERATE the system to verify the repair.</p> <p>No – INSTALL a new multifunction switch. REFER to Multifunction Switch in this section. OPERATE the system to verify the repair.</p>	<p>Horn Switch</p> <p>Multifunction Switch-W</p> <p>Multifunction Switch-L</p>

Horn Always On

Step	Action	Connector End View
1	<p>Did you read the Circuit Description and Operation?</p> <p>Yes – GO to Step 2.</p> <p>No – REFER to Circuit Description and Operation.</p>	
2	<p>Disconnect the horn relay harness connector.</p> <p>Does the horn stop sounding?</p> <p>Yes – GO to Step 3.</p> <p>No – REPAIR circuit 78. OPERATE the system to verify the repair.</p>	
3	<p>Connect a DVOM between the horn relay harness connector terminal 2 and the vehicle chassis.</p> <p>Does the DVOM display approximately 12 volts?</p> <p>Yes – GO to Step 4.</p> <p>No – INSTALL a new horn relay. OPERATE the system to verify the repair.</p>	<p>Horn Relay</p>
4	<p>1. Disconnect the multifunction switch harness connector W.</p> <p>2. Connect a DVOM between the horn relay harness connector terminal 2 and the vehicle chassis.</p>	<p>Horn Relay</p>

Step	Action	Connector End View
	<p>Does the DVOM display approximately 12 volts?</p> <p>Yes – REPAIR circuit 28. OPERATE the system to verify the repair.</p> <p>No – RECONNECT multifunction switch connector W. GO to Step 5.</p>	
5	<p>1. Disconnect the horn switch harness connector.</p> <p>2. Connect a DVOM between the horn relay harness connector terminal 2 and the vehicle chassis.</p> <p>Does the DVOM display approximately 12 volts?</p> <p>Yes – INSTALL a new multifunction switch. REFER to Multifunction Switch in this section. OPERATE the system to verify the repair.</p> <p>No – INSTALL a new horn switch. REFER to Horn Switch in this section. OPERATE the system to verify the repair.</p>	<p>Horn Switch</p> <p>Horn Relay</p>

Instrument Cluster Gauge

Circuit Description and Operation

The instrument cluster gauge is the main component of the electrical system. The four connectors on the back of the instrument cluster gauge are for the drive mode selector switch, the 12 volt harness, the 72 volt harness and the gauge overlay (for the Select/Reset Button). The instrument cluster gauge backlighting illuminates when the drive mode selector switch is placed in the Reverse, Turf or Drive position.

The brake indicator will display when either the park brake is engaged or the brake fluid level is low. The park brake switch closes when the park brake is set. The 12 volt return is supplied through the instrument cluster gauge from the DC/DC converter 1 to complete the circuit. When the brake fluid in the master cylinder is low, the brake fluid level switch closes. The 12 volt return is supplied through the instrument cluster gauge from the DC/DC converter 1 to complete the circuit. The instrument cluster gauge will display the park brake/fluid warning/rollaway reminder indicator when these conditions are met.

The warning chime is built into the instrument cluster gauge and provides audible warning when the drive mode selector switch is in the Reverse position. The audible warning also sounds for 10 seconds (as a rollaway reminder) when the drive mode selector switch is placed in the OFF position from any other position unless the park brake is engaged.

When the GFCI cord is connected to the charger, a signal is sent to the instrument cluster gauge. This signal activates the 120VAC energized indicator. This signal also inhibits the vehicle from activating any of the drive modes.

The battery water reminder indicator (flooded batteries only) will display every 300 miles (483 km) on vehicles equipped with flooded batteries. To reset the battery water reminder indicator, refer to [Resetting the Battery Water Reminder](#) in this section. The instrument cluster gauge must be set for the type of batteries that are installed in the vehicle to prevent excessive charge time or damage to the batteries. Refer to [Selecting Battery Type](#) in this section.

The drive system over-temp indicator will display when the drive system overheats. A fault code from the motor controller will activate the over-temp indicator. The indicator will remain on until the fault code from the motor controller disappears.

The electrical leakage indicator will display when electrical current is detected between the 72 volt harness or components and the vehicle chassis. The indicator will display regardless of the drive mode selector switch position. Although this condition may not affect the drive or accessory system functionality, the display of the electrical leakage indicator indicates a need for service. Make sure the vehicle is thoroughly dry before attempting electrical leakage diagnosis. Electrical leakage may be detected if certain electrical connectors are exposed to moisture due to rain or washing of the vehicle.

The odometer has five LCD positions that display total vehicle miles/kilometers. These positions are shared with the trip odometer. All digits will be displayed when in the odometer mode (trailing zeros will all be displayed). Refer to [Selecting Odometer or Trip Odometer Mode](#) in this section. The trip odometer starts with one digit and one decimal place (e.g. 0.0). More digits will be displayed as trip odometer counts up. Mileage is stored in non-volatile memory. In the event of unexpected power loss, software flash or placing the drive mode selector switch in the OFF position, mileage data will be maintained.

The seatbelt warning indicator will display for 30 seconds when the drive mode selector switch is placed in the Drive position. Switching to the Turf or Reverse position during the 30 second period will not affect the timer for the indicator. Placing the drive mode selector switch in the OFF position is the only way to clear the indicator before the 30 seconds has elapsed.

The service required (wrench) indicator will be displayed anytime a diagnostic trouble code sets due to a system malfunction.

The speedometer has two LCD positions that will display the vehicle speed in MPH or KPH, depending on the selected display mode. Refer to [Selecting Speed and Distance Units](#) in this section. The speedometer will function when the vehicle is in the Reverse, Turf or Drive positions.

The state of charge indicator displays the charge level of the battery pack. The number of lines/bars displayed indicates the state of charge. The motor controller outputs this information to the instrument cluster gauge through the serial communication lines. The State of Charge

Indicator Chart shows the battery pack voltage and corresponding instrument cluster gauge display.

The left and right turn signal indicators are green LEDs that flash with their respective turn signals.

State of Charge Indicator Chart

Battery Pack Voltage (Approximate)	State of Charge Indicator Bars Displayed	State of Charge Indicator Battery Outline Display	Additional Information
0 - 20 V	0 (or 5) bars	Flashing fast	Charger hums but does not charge. Vehicle will not drive.
20 - 63 V	0 (or 5) bars	Flashing fast	Charger charges at 2 amp rate. Vehicle will not drive.
63 - 68 V	0 (or 5) bars	Flashing fast	Charger charges at 10 amp rate. Vehicle will not drive.
68.3 – 69.8 V	0 (or 5) bars	Flashing fast	Charger charges at 10 amp rate. Vehicle will drive.
69.8 – 70.6 V	1 bar	Flashing slow	Charger charges at 10 amp rate. Vehicle will drive.
70.6 – 72 V	2 bars	Solid	Charger charges at 10 amp rate. Vehicle will drive.
72 – 73.4 V	3 bars	Solid	Charger charges at 10 amp rate. Vehicle will drive.
73.4 – 74.9 V	4 bars	Solid	Charger charges at 10 amp rate. Vehicle will drive.
74.9 – 80 V	5 bars	Solid	Charger charges at 10 amp rate. Vehicle will drive.

Selecting Speed and Distance Units

To change the speed and distance units between miles per hour (MPH) and kilometers per hour (KPH), set the park brake and perform the following:

1. While pressing the Select/Reset button, place the drive mode selector switch in the Drive position.
2. Release the Select/Reset button within 5 seconds.

3. Place the drive mode selector switch in the Turf position.
4. Press and release the Select/Reset button to alternate between MPH and KPH display.
5. Place the drive mode selector switch in the OFF position and either press the Select/Reset button or wait 10 seconds to exit.

The MPH and KPH indicators are the only items displayed when the instrument cluster gauge is in Selecting Speed and Distance Units mode.

Selecting Odometer or Trip Odometer Mode

To change the instrument cluster gauge display between the Odometer and the Trip Odometer mode, set the park brake and perform the following:

1. Place the drive mode selector switch in the Drive or Turf position.
2. Press and release the Select/Reset button within three seconds.

Resetting the Trip Odometer

To reset the trip odometer, set the park brake and perform the following:

1. Place the drive mode selector switch in the Drive or Turf position.
2. Set the odometer to the Trip mode. Refer to [Selecting Odometer or Trip Odometer Mode](#) in this section.
3. Press and hold the Select/Reset button for longer than three seconds.

Resetting the Battery Water Reminder

To reset the battery water reminder, set the park brake and perform the following:

1. Place the drive mode selector switch in the Reverse position.
2. Press and hold the Select/Reset button for longer than three seconds.

Circuit Diagram

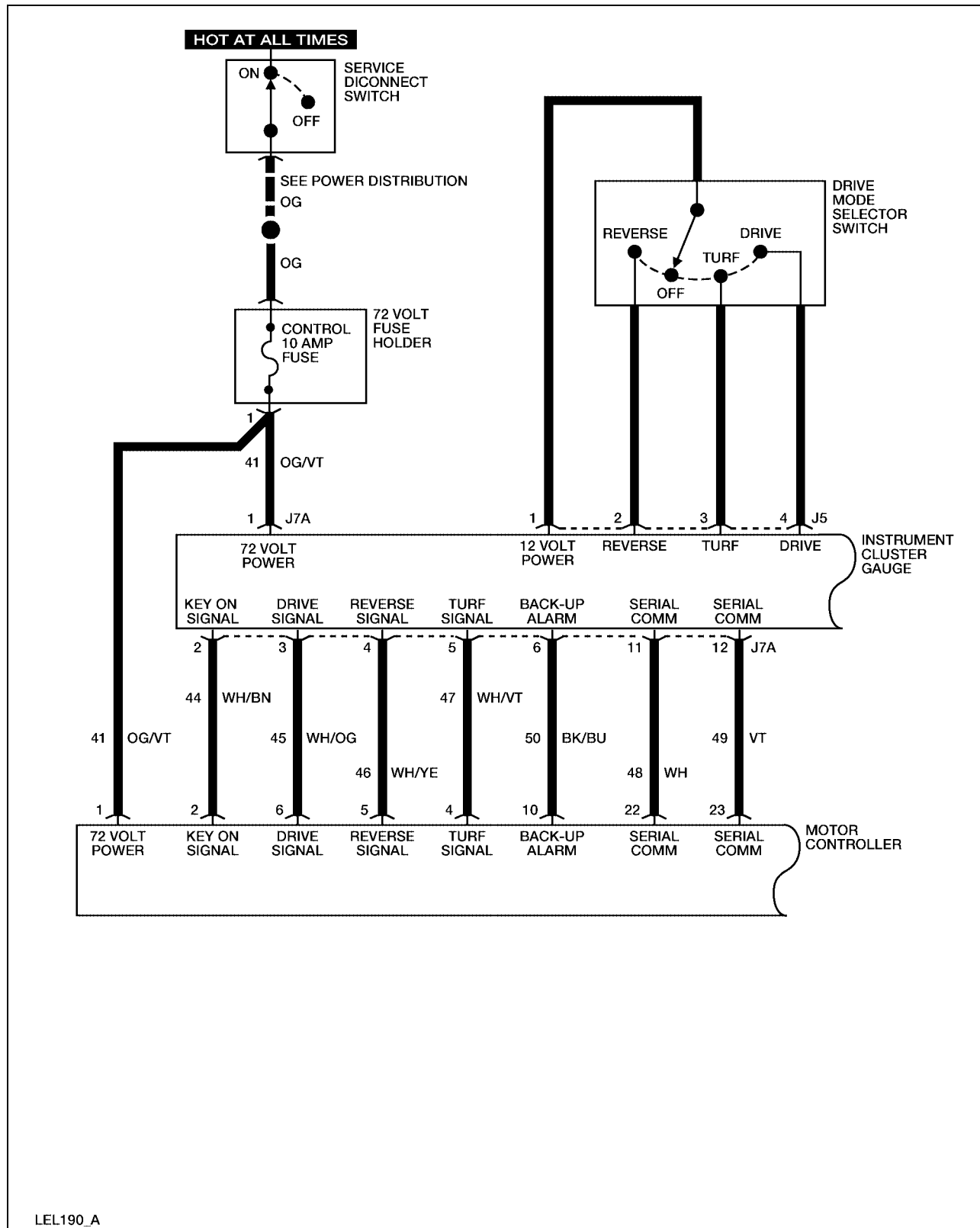

LEL190_A

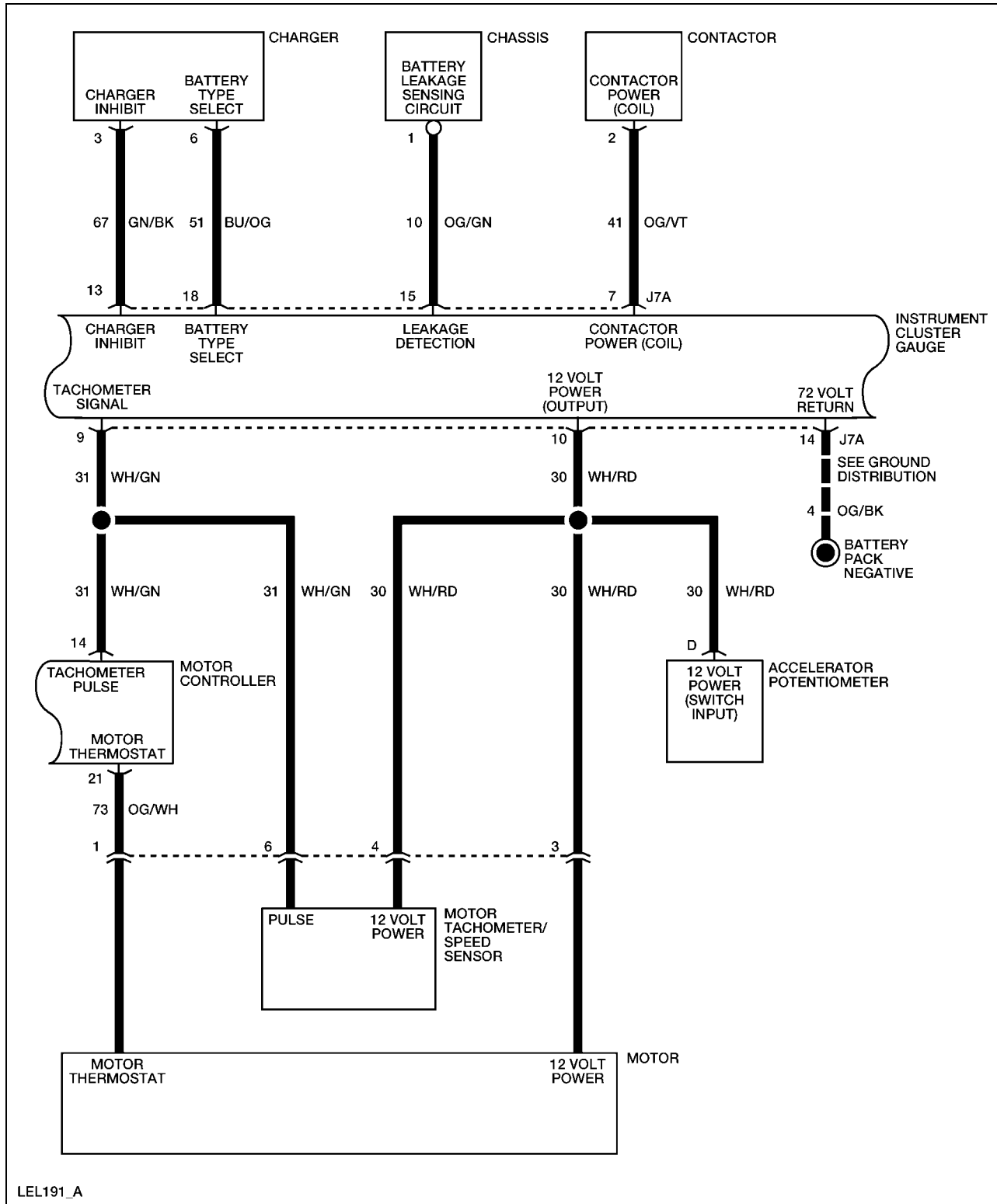

LEL191_A

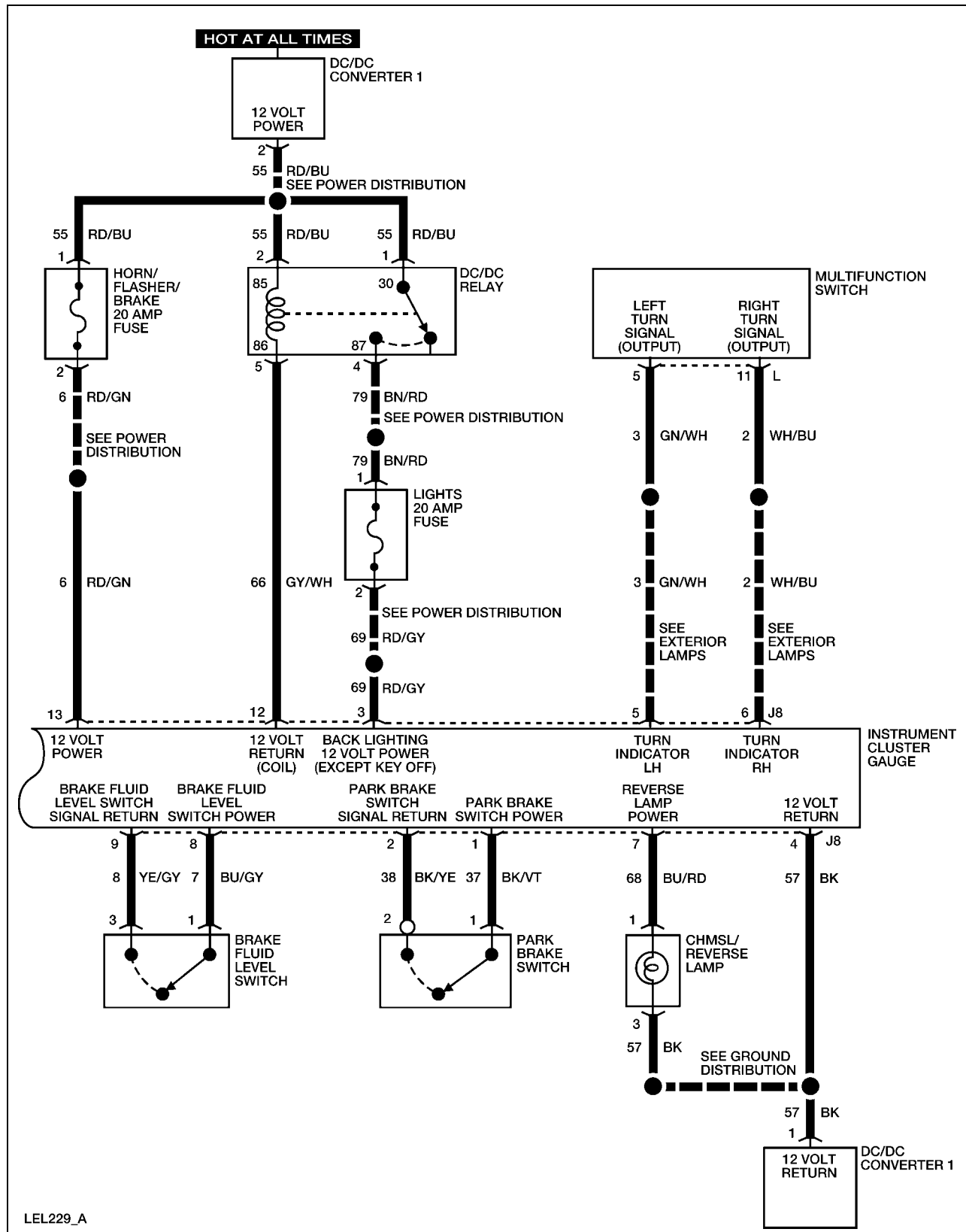

Required Tools

High Voltage Insulated Gloves	100-F036 or equivalent
Face Shield	100-F035 or equivalent

System Check

Functional components in the instrument cluster gauge system are:

- Service disconnect switch
- Instrument cluster gauge
- Control fuse
- Horn/flasher/brake fuse
- Lights fuse
- Motor controller
- Motor tachometer/speed sensor
- Accelerator potentiometer
- Charger
- Chassis
- Drive mode selector switch
- DC/DC converter 1 (standard)
- DC/DC relay
- Multifunction switch
- Brake fluid level switch
- Park brake switch
- CHMSL/reverse lamp
- Related wiring

Guidelines to diagnose the instrument cluster gauge system:

1. Verify the concern.
2. Check the fuse(s).
3. Check all connectors and related wiring for partially seated terminals, connectors not mating properly and for dirt, moisture or corrosion. For proper contact, terminal(s) must be free of all foreign material.
4. Make sure the service disconnect switch is in the ON position.
5. Fill the brake fluid reservoir as necessary.
6. Check for any diagnostic trouble codes. Refer to [Retrieving and Clearing DTCs](#).

If the concern still exists, refer to the following table:

Symptom Chart

Symptom	Possible Causes	Action
The instrument cluster gauge does not illuminate with the drive mode selector switch in the Reverse, Turf or Drive position	<ul style="list-style-type: none"> • Drive mode selector switch • Instrument cluster gauge • Connectors or related wiring 	GO to Instrument Cluster Gauge .
The state of charge indicator is inoperative	<ul style="list-style-type: none"> • Instrument cluster gauge • Motor controller • Connectors or related wiring 	GO to State of Charge Indicator Inoperative .
The speedometer indicator is inoperative	<ul style="list-style-type: none"> • Instrument cluster gauge • Motor tachometer/speed sensor • Connectors or related wiring 	GO to Instrument Cluster Gauge Does Not Display Correct Vehicle Speed .
The odometer/trip odometer is inoperative	<ul style="list-style-type: none"> • Instrument cluster gauge • Connectors or related wiring 	GO to Odometer/Trip Odometer Inoperative .
The park brake/rollaway reminder chime is always on	<ul style="list-style-type: none"> • Instrument cluster gauge 	INSTALL a new instrument cluster gauge. REFER to

Symptom	Possible Causes	Action
		Instrument Cluster Gauge in this section. OPERATE the system to verify the repair.
The reverse chime is always on	<ul style="list-style-type: none"> Instrument cluster gauge 	INSTALL a new instrument cluster gauge. REFER to Instrument Cluster Gauge in this section. OPERATE the system to verify the repair.
The reverse chime is always on	<ul style="list-style-type: none"> Instrument cluster gauge 	INSTALL a new instrument cluster gauge. REFER to Instrument Cluster Gauge in this section. OPERATE the system to verify the repair.
The park brake/rollaway reminder chime is inoperative	<ul style="list-style-type: none"> Instrument cluster gauge Park brake switch Connectors or related wiring 	GO to Park Brake/ Rollaway Reminder Chime Inoperative.
The seatbelt warning indicator is always on	<ul style="list-style-type: none"> Instrument cluster gauge Connectors or related wiring 	GO to Seatbelt Warning Indicator Always On.
The seatbelt warning indicator is inoperative	<ul style="list-style-type: none"> Instrument cluster gauge 	INSTALL a new instrument cluster gauge. REFER to Instrument Cluster Gauge in this section. OPERATE the system to verify the repair.
The battery water reminder indicator is always on	<ul style="list-style-type: none"> Instrument cluster gauge Connectors or related wiring 	GO to Battery Water Reminder Indicator Always On.
The battery water reminder indicator is inoperative	<ul style="list-style-type: none"> Instrument cluster gauge Incorrect battery type selected 	GO to Battery Water Reminder Indicator Inoperative.
The electrical leakage indicator is always on	<ul style="list-style-type: none"> Instrument cluster gauge Connectors or related wiring 	GO to Electrical Leakage Indicator Always On.
When the GFCI charger cord is connected to the charger,	<ul style="list-style-type: none"> Instrument cluster gauge 	GO to 120VAC Energized

Symptom	Possible Causes	Action
the 120VAC energized indicator does not display	<ul style="list-style-type: none"> Connectors or related wiring 	Indicator Inoperative.
The 120VAC energized indicator is always on	<ul style="list-style-type: none"> Instrument cluster gauge Connectors or related wiring 	GO to 120VAC Energized Indicator Always On.
The service required (wrench) indicator is always on	<ul style="list-style-type: none"> Instrument cluster gauge Connectors or related wiring 	GO to Service Required Indicator Always On.
The drive system over-temp indicator is always on but vehicle has normal performance	<ul style="list-style-type: none"> Instrument cluster gauge 	INSTALL a new instrument cluster gauge. REFER to Instrument Cluster Gauge in this section. TEST the system to verify the repair.
The drive system over-temp indicator is always on and vehicle has sluggish performance	<ul style="list-style-type: none"> Instrument cluster gauge Connectors or related wiring 	GO to Drive System Over-Temp Indicator Always On.
The park brake indicator does not turn on when the park brake is applied	<ul style="list-style-type: none"> Parking brake switch Connectors or related wiring 	GO to Park Brake/Fluid Warning/Rollaway Reminder Indicator Inoperative.
The brake warning indicator is always on	<ul style="list-style-type: none"> Brake fluid switch Parking brake switch Connectors or related wiring 	GO to Park Brake/Fluid Warning/Rollaway Reminder Indicator Always On.

Diagnostic System Check

Note: Before performing the diagnostic system check, perform the following:

1. Set the park brake.
2. Cycle the service disconnect switch OFF and then ON.
3. Place the drive mode selector switch in the Drive position, then to the OFF position.
4. Check all vehicle fuses.

The Diagnostic System Check helps identify and diagnose the instrument cluster gauge and related vehicle system failures. Use the chart below as a starting point for all instrument cluster gauge diagnosis.

Step	Action	Connector End View
1	<p>Attempt to enter Selecting Battery Type mode. Refer to Selecting Battery Type in this section.</p> <p>Does the instrument cluster gauge enter Selecting Battery Type mode?</p> <p>Yes - GO to Step 2.</p> <p>No - REFER to Instrument Cluster Gauge in this section.</p>	
2	<p>Attempt to enter Selecting Speed and Distance Units mode. Refer to Selecting Speed and Distance Units.</p> <p>Does the instrument cluster gauge enter Selecting Speed and Distance Units mode?</p> <p>Yes - GO to Step 3.</p> <p>No - REFER to Instrument Cluster Gauge in this section.</p>	
3	<p>Attempt to enter Retrieving and Clearing DTCs mode. Refer to Retrieving and Clearing DTCs.</p> <p>Does the instrument cluster gauge enter Retrieving and Clearing DTCs mode?</p> <p>Yes - GO to Step 4.</p> <p>No - REFER to Instrument Cluster Gauge Inoperative in this section.</p>	
4	<p>Does the instrument cluster gauge display any DTCs?</p> <p>Yes - REFER to Diagnostic Trouble Code (DTC) Chart.</p> <p>No - REFER to Symptom Chart in this section.</p>	

DC/DC Relay Test

Step	Action	Connector End View
1	<ol style="list-style-type: none"> 1. Set the park brake. 2. Place the drive mode selector switch in the Reverse, Turf or Drive position. <p>Does the horn sound? Yes - GO to Step 2. No - REFER to Horn Inoperative in this section.</p>	
2	<ol style="list-style-type: none"> 1. Disconnect the DC/DC relay harness connector. 2. Connect a DVOM between the DC/DC relay harness connector terminal 1 and the vehicle chassis. 3. Connect a DVOM between the DC/DC relay harness connector terminal 2 and the vehicle chassis. <p>Does the display approximately 12 volts? Yes – GO to Step 3. No – REPAIR circuit 55. OPERATE the system to verify the repair.</p>	DC/DC Relay
3	<p>Connect a DVOM between the DC/DC relay harness connector terminal 1 and terminal 5.</p> <p>Does the display approximately 12 volts? Yes – GO to Step 5. No – GO to Step 4.</p>	DC/DC Relay
4	<ol style="list-style-type: none"> 1. Disconnect the instrument cluster gauge harness connector J8. 2. Connect a DVOM between the instrument cluster gauge harness connector J8 terminal 12 and the DC/DC relay harness connector terminal 5. <p>Does continuity exist? Yes – INSTALL a new instrument cluster gauge. REFER to Instrument Cluster Gauge in this section. OPERATE the system to verify the repair. No – REPAIR circuit 66. OPERATE the system to verify the repair.</p>	Instrument Cluster Gauge – J8 DC/DC Relay
5	<ol style="list-style-type: none"> 1. Remove the lights fuse. 2. Remove the wiper/washer fuse. 3. Connect a DVOM between the DC/DC relay harness connector terminal 4 and the lights fuse terminal 1. 	DC/DC Relay

Step	Action	Connector End View
	<p>4. Connect a DVOM between the DC/DC relay harness connector terminal 4 and the wiper/washer fuse terminal 1.</p> <p>Does continuity exist?</p> <p>Yes – GO to Step 6.</p> <p>No – REPAIR circuit 79. OPERATE the system to verify the repair.</p>	
6	<ol style="list-style-type: none"> 1. Remove the lights fuse from the 72 volt fuse holder. 2. Disconnect the multifunction switch harness connector – L. 3. Connect a DVOM between the lights fuse terminal 2 and the multifunction switch harness connector – L terminal 9. 4. Connect a DVOM between the lights fuse terminal 2 and the multifunction switch harness connector – L terminal 6. 5. Connect a DVOM between the lights fuse terminal 2 and the multifunction switch harness connector – L terminal 4. 6. Connect a DVOM between the lights fuse terminal 2 and the instrument cluster gauge harness connector J8 terminal 3. <p>Does continuity exist?</p> <p>Yes – INSTALL a new DC/DC relay. OPERATE the system to verify the repair.</p> <p>No – REPAIR circuit 69. OPERATE the system to verify the repair.</p>	<p>Multifunction Switch – L</p> <p>Instrument Cluster Gauge – J8</p>

DTC 09

Description:

Both the forward and reverse direction switches are closed at the same time.

Symptom:

Motor controller will not operate.

Possible cause(s):

- Drive mode selector switch.
- Instrument cluster gauge.

Step	Action	Connector End View
1	<p>Did you perform the Diagnostic System Check?</p> <p>Yes - GO to Step 2.</p> <p>No - REFER to Diagnostic System Check.</p>	
2	<ol style="list-style-type: none"> 1. Disconnect the drive mode selector switch connector J5. 2. Place the drive mode selector switch in the Drive position. 3. Connect a DVOM between the drive mode selector switch terminal 1 and terminal 2. 4. Connect a DVOM between the drive mode selector switch terminal 1 and terminal 3. <p>Does continuity exist for either test?</p> <p>Yes - INSTALL a new drive mode selector switch. REFER to Drive Mode Selector Switch. OPERATE the system to verify the repair.</p> <p>No - GO to Step 3.</p>	Drive Mode Selector Switch
3	<ol style="list-style-type: none"> 1. Place the drive mode selector switch in the Turf position. 2. Connect a DVOM between drive mode selector switch terminal 1 and terminal 2. 3. Connect a DVOM between the drive mode selector switch terminal 1 and terminal 4. <p>Does continuity exist for either test?</p> <p>Yes - INSTALL a new drive mode selector switch. REFER to Drive Mode Selector Switch in this section. OPERATE the system to verify the repair.</p> <p>No - GO to Step 4.</p>	Drive Mode Selector Switch
4	<ol style="list-style-type: none"> 1. Place the drive mode selector switch in the Reverse position. 2. Connect a DVOM between drive mode selector switch 	Drive Mode Selector Switch

Step	Action	Connector End View
	<p>terminal 1 and terminal 3.</p> <p>3. Connect a DVOM between the drive mode selector switch terminal 1 and terminal 4.</p> <p>Does continuity exist for either test?</p> <p>Yes - INSTALL a new drive mode selector switch. REFER to Drive Mode Selector Switch. OPERATE the system to verify the repair.</p> <p>No – GO to Step 5.</p>	
5	<p>1. Disconnect the instrument cluster gauge harness connector J7A and the motor controller harness connector.</p> <p>2. Connect a DVOM between the instrument cluster gauge harness connector J7A terminal 4 and terminal 3.</p> <p>3. Connect a DVOM between the instrument cluster gauge harness connector J7A terminal 4 and terminal 5.</p> <p>Does continuity exist?</p> <p>Yes – REPAIR circuit 45, 46 or 47. OPERATE the system to verify the repair.</p> <p>No – INSTALL a new instrument cluster gauge. REFER to Instrument Cluster Gauge in this section. OPERATE the system to verify the repair.</p>	

Instrument Cluster Gauge Inoperative

WARNING:

THE BATTERY PACK ASSEMBLY CAN DELIVER IN EXCESS OF 72 VOLTS OF DC POWER. IMPROPER HANDLING OF THE BATTERY PACK CAN RESULT IN INJURY OR FATALITY. ONLY AUTHORIZED PERSONNEL TRAINED TO WORK WITH BATTERY PACK COMPONENTS ARE PERMITTED TO HANDLE THE BATTERIES.

WARNING:

THE BATTERY PACK CONTAINS HIGH-VOLTAGE COMPONENTS AND WIRING. HIGH-VOLTAGE INSULATED SAFETY GLOVES AND FACE SHIELD MUST BE WORN WHEN PERFORMING THE FOLLOWING STEPS. FAILURE TO FOLLOW THIS WARNING MAY RESULT IN SEVERE PERSONAL INJURY OR DEATH.

Step	Action	Connector End View
1.	<p>Did you read the Circuit Description and Operation?</p> <p>Yes - GO to Step 2.</p> <p>No - REFER to Circuit Description and Operation in this section.</p>	
2.	<p>1. Set the park brake.</p> <p>2. Place the drive mode selector switch in the Reverse, Turf or Drive position.</p> <p>Does the instrument cluster gauge function properly and back lighting illuminate?</p> <p>Yes – The system is OK.</p> <p>No - GO to Step 3.</p>	
3.	<p>Connect a DVOM between the instrument cluster gauge connector J8 terminal 3 and the vehicle chassis.</p> <p>Does the DVOM display approximately 12 volts?</p> <p>Yes – GO to Step 4.</p> <p>No – REFER to DC/DC Relay Test.</p>	Instrument Cluster Gauge – J8
4.	<p>Connect a DVOM between the instrument cluster gauge connector J7A terminal 1 and the battery pack negative.</p> <p>Does the DVOM display approximately 72 volts?</p> <p>Yes – GO to Step 5.</p> <p>No – INSTALL a new 72 volt harness. OPERATE the system to verify the repair.</p>	Instrument Cluster Gauge – J7A
5.	<p>1. Disconnect the instrument cluster gauge harness connector J8.</p> <p>2. Connect a DVOM between the instrument cluster gauge harness connector J8 terminal 4 and the vehicle chassis.</p> <p>Does continuity exist?</p> <p>Yes - GO to Step 6.</p> <p>No – REPAIR circuit 57. OPERATE the system to verify the repair.</p>	Instrument Cluster Gauge – J8

Step	Action	Connector End View
6.	<p>Connect a DVOM between the instrument cluster gauge harness connector J7A terminal 14 and the battery pack negative.</p> <p>Does continuity exist?</p> <p>Yes - GO to Step 7.</p> <p>No – INSTALL a new 72 volt harness. OPERATE the system to verify the repair.</p>	Instrument Cluster Gauge – J7A
7.	<ol style="list-style-type: none"> 1. Reconnect the instrument cluster gauge harness connector J8. 2. Disconnect the drive mode selector switch harness connector. 3. Connect a DVOM between the drive mode selector switch harness connector terminal 2 and the vehicle chassis. <p>Does the DVOM display approximately 12 volts?</p> <p>Yes – GO to Step 8.</p> <p>No – INSTALL a new instrument cluster gauge. REFER to Instrument Cluster Gauge in this section. OPERATE the system to verify the repair.</p>	Drive Mode Selector Switch – J5
8.	<p>Connect a fused jumper wire between the drive mode selector switch harness connector J5 terminal 1 and terminal 2 (on the component side).</p> <p>Does the instrument cluster gauge backlighting illuminate?</p> <p>Yes – GO to Step 9.</p> <p>No – INSTALL a new instrument cluster gauge. REFER to Instrument Cluster Gauge in this section. OPERATE the system to verify the repair.</p>	Drive Mode Selector Switch – J5
9.	<p>Connect a fused jumper wire between the drive mode selector switch harness connector J5 terminal 1 and terminal 3 (on the component side).</p> <p>Does the instrument cluster gauge backlighting illuminate?</p> <p>Yes – GO to Step 10.</p> <p>No – INSTALL a new instrument cluster gauge. REFER to Instrument Cluster Gauge in this section. OPERATE the</p>	Drive Mode Selector Switch – J5

Step	Action	Connector End View
	system to verify the repair.	
10.	<p>Connect a fused jumper wire between the drive mode selector switch harness connector J5 terminal 1 and terminal 4 (on the component side).</p> <p>Does the instrument cluster gauge backlighting illuminate?</p> <p>Yes – INSTALL a new drive mode selector switch. REFER to Drive Mode Selector Switch in this section. OPERATE the system to verify the repair.</p> <p>No – INSTALL a new instrument cluster gauge. REFER to Instrument Cluster Gauge in this section. OPERATE the system to verify the repair.</p>	Drive Mode Selector Switch – J5

State of Charge Indicator Inoperative

Step	Action	Connector End View
1	<p>Did you read the Circuit Description and Operation?</p> <p>Yes - GO to Step 2.</p> <p>No - REFER to Circuit Description and Operation in this section.</p>	
2	<p>1. Set the park brake.</p> <p>2. Place the drive mode selector switch in the Reverse, Turf or Drive position.</p> <p>Does the instrument cluster gauge backlighting illuminate?</p> <p>Yes – GO to Step 3.</p> <p>No - REFER to Instrument Cluster Gauge in this section.</p>	
3	<p>Connect a DVOM between the battery pack positive and the battery pack negative.</p> <p>Does the state of charge indicator display correspond to the voltage displayed on the DVOM?</p> <p>Yes – The system is OK.</p> <p>No – INSTALL a new instrument cluster gauge. REFER to Instrument Cluster Gauge in this section. OPERATE the system to verify the repair.</p>	

Seatbelt Warning Indicator Always On

Step	Action	Connector End View
1	<p>Did you read the Circuit Description and Operation?</p> <p>Yes - GO to Step 2.</p> <p>No – REFER to Circuit Description and Operation in this section.</p>	
2	<p>1. Set the park brake.</p> <p>2. Place the drive mode selector switch in the Reverse, Turf or Drive position.</p> <p>Does the seatbelt indicator display for 30 seconds and then go out?</p> <p>Yes – The system is OK.</p> <p>No - INSTALL a new instrument cluster gauge. REFER to Instrument Cluster Gauge in this section. OPERATE the system to verify the repair.</p>	

Odometer/Trip Odometer Inoperative

Step	Action	Connector End View
1	<p>Did you read the Circuit Description and Operation?</p> <p>Yes - GO to Step 2.</p> <p>No - REFER to Circuit Description and Operation in this section.</p>	
2	<p>1. Set the park brake.</p> <p>2. Place the drive mode selector switch in the Reverse, Turf or Drive position.</p> <p>Does the instrument cluster gauge backlighting illuminate?</p> <p>Yes - GO to Step 3.</p> <p>No - REFER to Instrument Cluster Gauge Inoperative.</p>	
3	<p>Press and hold the Select/Reset button for three seconds and then release it.</p> <p>Does the odometer/trip odometer display reset to 0?</p> <p>Yes – The system is OK.</p> <p>No – INSTALL a new instrument cluster gauge. REFER to Instrument Cluster Gauge in this section. OPERATE the system to verify the repair.</p>	

Battery Water Reminder Indicator Always On

Step	Action	Connector End View
1	<p>Did you read the Circuit Description and Operation? Yes - GO to Step 2. No - REFER to Circuit Description and Operation in this section.</p>	
2	<p>1. Set the park brake. 2. Place the drive mode selector switch in the Reverse, Turf or Drive position. Does the instrument cluster gauge backlighting illuminate? Yes - GO to Step 3. No – REFER to Instrument Cluster Gauge Inoperative in this section.</p>	
3	<p>1. Set the park brake. 2. Place the drive mode selector switch in the Reverse position. 3. Press and hold the Select/Reset button for three seconds and then release it. Does the battery water reminder indicator remain on? Yes – INSTALL a new instrument cluster gauge. REFER to Instrument Cluster Gauge in this section. OPERATE the system to verify the repair. No – The system is OK.</p>	

Battery Water Reminder Indicator Inoperative

Step	Action	Connector End View
1	<p>Did you read the Diagnostic System Check? Yes - GO to Step 2. No - REFER to Diagnostic System Check in this section.</p>	
2	<p>1. Set the park brake. 2. Place the drive mode selector switch in the Reverse, Turf or Drive position. Does the instrument cluster gauge backlighting illuminate? Yes - GO to Step 3. No – REFER to Instrument Cluster Gauge Inoperative in this section.</p>	

Step	Action	Connector End View
3	<ol style="list-style-type: none"> 1. Place the drive mode selector switch in the OFF position. 2. Place the drive mode selector switch in the Reverse position. 3. Press and hold the Select/Reset button for three seconds and then release it. <p>Does the battery water reminder indicator display when the drive mode selector switch is initially placed in the Reverse, Turf or Drive position?</p> <p>Yes – The system is OK. No – GO to Step 4.</p>	
4	<p>Verify that the correct battery type is set in the instrument cluster gauge. Refer to Selecting Battery Type in this section.</p> <p>Does the battery water reminder indicator display when flooded battery mode is selected?</p> <p>Yes – The system is OK. No – INSTALL a new instrument cluster gauge. REFER to Instrument Cluster Gauge in this section. OPERATE the system to verify the repair.</p>	

Electrical Leakage Indicator Always On

WARNING:

THE BATTERY PACK ASSEMBLY CAN DELIVER IN EXCESS OF 72 VOLTS OF DC POWER. IMPROPER HANDLING OF THE BATTERY PACK CAN RESULT IN INJURY OR FATALITY. ONLY AUTHORIZED PERSONNEL TRAINED TO WORK WITH BATTERY PACK COMPONENTS ARE PERMITTED TO HANDLE THE BATTERIES.

WARNING:

THE BATTERY PACK CONTAINS HIGH-VOLTAGE COMPONENTS AND WIRING. HIGH-VOLTAGE INSULATED SAFETY GLOVES AND FACE SHIELD MUST BE WORN WHEN PERFORMING THE FOLLOWING STEPS. FAILURE TO FOLLOW THIS WARNING MAY RESULT IN SEVERE PERSONAL INJURY OR DEATH.

Step	Action	Connector End View
1	Did you read the Circuit Description and Operation? Yes - GO to Step 2. No - REFER to Circuit Description and Operation in this section.	
2	Disconnect the chassis connector and wait for 30 seconds. Does the electrical leakage indicator remain on? Yes – INSTALL a new instrument cluster gauge. REFER to Instrument Cluster Gauge in this section. OPERATE the system to verify the repair. No – REFER to Electrical Leakage Detection in this section.	

120VAC Energized Indicator Inoperative

Step	Action	Connector End View
1	Did you read the Circuit Description and Operation? Yes - GO to Step 2. No - REFER to Circuit Description and Operation in this section.	
2	1. Place the drive mode selector switch in the OFF position and remove the key. 2. Connect the GFCI cord to the charger. Does the 120VAC energized indicator display on the instrument cluster gauge? Yes – GO to Step 3. No – GO to Step 4.	
3	Disconnect the GFCI cord from the charger. Does the 120VAC energized indicator remain on? Yes – REFER to 120VAC Energized Indicator Always On in this section. No – The system is OK.	
4	1. Disconnect the charger harness connector. 2. Disconnect the instrument cluster gauge harness connector J7A. 3. Connect a DVOM between the charger harness	Charger Instrument Cluster Gauge – J7A

Step	Action	Connector End View
	<p>connector terminal 3 and the instrument cluster gauge harness connector J7A terminal 13.</p> <p>Does continuity exist?</p> <p>Yes – GO to Step 5.</p> <p>No – INSTALL a new 72 volt harness. REFER to Wiring Harnesses in this section. OPERATE the system to verify the repair.</p>	
5	<ol style="list-style-type: none"> 1. Reconnect the charger harness connector. 2. Connect a DVOM between the instrument cluster gauge harness connector J7A terminal 13 and the battery pack positive. <p>Does the DVOM display approximately 72 volts?</p> <p>Yes – GO to Step 6.</p> <p>No – INSTALL a new charger. REFER to Charger in this section. OPERATE the system to verify the repair.</p>	Instrument Cluster Gauge – J7A
6	<ol style="list-style-type: none"> 1. Connect the GFCI cord to the charger. 2. Connect a DVOM between the instrument cluster gauge connector J7A terminal 13 and the battery pack positive. <p>Does the DVOM display approximately 0 volts?</p> <p>Yes – INSTALL a new instrument cluster gauge. REFER to Instrument Cluster Gauge in this section. OPERATE the system to verify the repair.</p> <p>No – INSTALL a new charger. REFER to Charger in this section. OPERATE the system to verify the repair.</p>	Instrument Cluster Gauge – J7A

120VAC Energized Indicator Always On

Step	Action	Connector End View
1	<p>Did you read the Circuit Description and Operation?</p> <p>Yes - GO to Step 2.</p> <p>No - REFER to Circuit Description and Operation in this section.</p>	
2	<ol style="list-style-type: none"> 1. Make sure the GFCI cord is not connected to the charger. 2. Disconnect the instrument cluster gauge harness 	Instrument Cluster Gauge – J7A

Step	Action	Connector End View
	<p>connector J7A.</p> <p>3. Connect a DVOM between the instrument cluster gauge harness connector J7A terminal 13 and the battery pack positive.</p> <p>Does the DVOM display approximately 72 volts?</p> <p>Yes – GO to Step 3.</p> <p>No – INSTALL a new instrument cluster gauge. REFER to Instrument Cluster Gauge in this section. OPERATE the system to verify the repair.</p>	
3	<p>1. Disconnect the charger harness connector.</p> <p>2. Connect a DVOM between the charger harness connector terminal 3 and the battery pack positive.</p> <p>Does the DVOM display approximately 72 volts?</p> <p>Yes – INSTALL a new charger. REFER to Charger in this section. OPERATE the system to verify the repair.</p> <p>No – INSTALL a new 72 volt harness. REFER to Wiring Harnesses in this section. OPERATE the system to verify the repair.</p>	Charger

Service Required Indicator Always On

Step	Action	Connector End View
1	<p>Did you read the Circuit Description and Operation?</p> <p>Yes - GO to Step 2.</p> <p>No - REFER to Circuit Description and Operation in this section.</p>	
2	<p>1. Set the park brake.</p> <p>2. Place the drive mode selector switch in the Reverse, Turf or Drive position.</p> <p>Does the instrument cluster gauge backlighting illuminate?</p> <p>Yes – GO to Step 3.</p> <p>No - REFER to Instrument Cluster Gauge Inoperative.</p>	
3	<p>Check for DTCs. Refer to Retrieving and Clearing DTCs.</p> <p>Are any DTCs displayed?</p> <p>Yes – REFER to Diagnostic Trouble Code (DTC) Chart.</p>	

Step	Action	Connector End View
	No – INSTALL a new instrument cluster gauge. REFER to Instrument Cluster Gauge in this section. OPERATE the system to verify the repair.	

Drive System Over-Temp Indicator Always On

Step	Action	Connector End View
1	Did you read the Circuit Description and Operation? Yes - GO to Step 2. No - REFER to Circuit Description and Operation in this section.	
2	1. Set the park brake. 2. Place the drive mode selector switch in the Reverse, Turf or Drive position. Does the instrument cluster gauge backlighting illuminate? Yes - GO to Step 3. No – REFER to Instrument Cluster Gauge Inoperative in this section.	
3	Check the motor tachometer/speed sensor connector for loose connection or damage. Is the motor tachometer/speed sensor connector OK? Yes – GO to Step 4. No – REPAIR the motor tachometer/speed sensor connection. OPERATE the system to verify the repair.	Motor Tachometer/Speed Sensor
4	1. Park the vehicle and allow the motor to cool. 2. Disconnect the motor tachometer/speed sensor connector. 3. Connect a DVOM between the motor tachometer/speed sensor harness connector terminal 1 and terminal 3. Does continuity exist? Yes – GO to Step 5. No – INSTALL a new motor. REFER to Motor in the Powertrain section. OPERATE the system to verify the repair.	Instrument Cluster Gauge – J7A Motor Controller
5	1. Disconnect the motor controller harness connector. 2. Connect a DVOM between the motor tachometer/speed	Motor Tachometer/Speed

Step	Action	Connector End View
	sensor harness connector terminal 1 and the motor controller harness connector terminal 21. Does continuity exist? Yes – GO to Step 6. No – INSTALL a new 72 volt harness. REFER to Wiring Harnesses in this section. OPERATE the system to verify the repair.	Sensor
6	1. Disconnect the instrument cluster gauge connector J7A. 2. Connect a DVOM between the motor tachometer/speed sensor harness connector terminal 3 and the instrument cluster gauge harness connector terminal 10. Does continuity exist? Yes – INSTALL a new motor controller. REFER to Motor Controller in the Powertrain section. OPERATE the system to verify the repair. No – INSTALL a new 72 volt harness. REFER to Wiring Harnesses in this section. OPERATE the system to verify the repair.	Motor Tachometer/Speed Sensor Instrument Cluster Gauge – J7A

Park Brake/Fluid Warning/Rollaway Reminder Indicator Inoperative

WARNING:

THE BATTERY PACK ASSEMBLY CAN DELIVER IN EXCESS OF 72 VOLTS OF DC POWER. IMPROPER HANDLING OF THE BATTERY PACK CAN RESULT IN INJURY OR FATALITY. ONLY AUTHORIZED PERSONNEL TRAINED TO WORK WITH BATTERY PACK COMPONENTS ARE PERMITTED TO HANDLE THE BATTERIES.

WARNING:

THE BATTERY PACK CONTAINS HIGH-VOLTAGE COMPONENTS AND WIRING. HIGH-VOLTAGE INSULATED SAFETY GLOVES AND FACE SHIELD MUST BE WORN WHEN PERFORMING THE FOLLOWING STEPS. FAILURE TO FOLLOW THIS WARNING MAY RESULT IN SEVERE PERSONAL INJURY OR DEATH.

Step	Action	Connector End View
1	<p>Did you read the Circuit Description and Operation? Yes - GO to Step 3. No - REFER to Circuit Description and Operation in this section..</p>	
2	<p>1. Set the park brake. 2. Place the drive mode selector switch in the Reverse, Turf or Drive position. Does the instrument cluster gauge backlighting illuminate? Yes – GO to Step 3. No – REFER to Instrument Cluster Gauge Inoperative in this section..</p>	
3	<p>Make sure the park brake is set. Does the instrument cluster gauge display the park brake/fluid warning/rollaway reminder indicator? Yes – GO to Step 4. No - GO to Step 5.</p>	
4	<p>With the park brake switch connected, remove the cap from the brake fluid reservoir. Does the instrument cluster gauge display the park brake/fluid warning/rollaway reminder indicator? Yes – The system is OK. No - GO to Step 5.</p>	
5	<p>1. Disconnect the instrument cluster gauge harness connector J8. 2. Disconnect the park brake switch harness connector. 3. Connect a DVOM between the instrument cluster gauge connector J8 terminal 1 and connector J8 terminal 2 and the park brake switch harness connector terminal 1. Does continuity exist? Yes – GO to Step 6. No - REPAIR circuit 37. OPERATE the system to verify the repair.</p>	<p>Instrument Cluster Gauge – J8 Park Brake Switch</p>
6	<p>Connect a DVOM between the instrument cluster gauge harness connector J8 terminal 2 and the park brake switch harness connector terminal 2.</p>	<p>Instrument Cluster Gauge – J8 Park Brake Switch</p>

Step	Action	Connector End View
	<p>Does continuity exist?</p> <p>Yes – GO to Step 7.</p> <p>No – REPAIR circuit 38. OPERATE the system to verify the repair.</p>	
7	<p>1. Disconnect the brake fluid level switch harness connector.</p> <p>2. Connect a DVOM between the instrument cluster gauge connector J8 terminal 8 and the brake fluid level switch harness connector terminal 1.</p> <p>Does continuity exist?</p> <p>Yes – GO to Step 8.</p> <p>No – REPAIR circuit 7. OPERATE the system to verify the repair.</p>	<p>Instrument Cluster Gauge – J8</p> <p>Brake Fluid Level Switch</p>
8	<p>Connect a DVOM between the instrument cluster gauge connector J8 terminal 9 and the brake fluid level switch harness connector terminal 2.</p> <p>Does continuity exist?</p> <p>Yes – GO to Step 9.</p> <p>No – REPAIR circuit 8. OPERATE the system to verify the repair.</p>	<p>Instrument Cluster Gauge – J8</p> <p>Brake Fluid Level Switch</p>
9	<p>1. Reconnect the instrument cluster gauge harness connector J8.</p> <p>2. Connect a DVOM between the brake fluid level switch harness connector terminal 1 and terminal 3.</p> <p>Does the DVOM display approximately 6 volts?</p> <p>Yes – INSTALL a new brake fluid level switch. OPERATE the system to verify the repair.</p> <p>No – INSTALL a new instrument cluster gauge. REFER to Instrument Cluster Gauge in this section. OPERATE the system to verify the repair.</p>	<p>Brake Fluid Level Switch</p>

Park Brake/Fluid Warning/Rollaway Reminder Indicator Always On

WARNING:

THE BATTERY PACK ASSEMBLY CAN DELIVER IN EXCESS OF 72 VOLTS OF DC POWER. IMPROPER HANDLING OF THE BATTERY PACK CAN RESULT IN INJURY OR FATALITY. ONLY AUTHORIZED PERSONNEL TRAINED TO WORK

WITH BATTERY PACK COMPONENTS ARE PERMITTED TO HANDLE THE BATTERIES.

WARNING:

THE BATTERY PACK CONTAINS HIGH-VOLTAGE COMPONENTS AND WIRING. HIGH-VOLTAGE INSULATED SAFETY GLOVES AND FACE SHIELD MUST BE WORN WHEN PERFORMING THE FOLLOWING STEPS. FAILURE TO FOLLOW THIS WARNING MAY RESULT IN SEVERE PERSONAL INJURY OR DEATH.

Step	Action	Connector End View
1	<p>Did you read the Circuit Description and Operation? Yes – GO to Step 3. No - REFER to Circuit Description and Operation in this section.</p>	
2	<p>1. Set the park brake. 2. Place the drive mode selector switch in the Reverse, Turf or Drive position. Does the instrument cluster gauge backlighting illuminate? Yes – GO to Step 3. No – REFER to Instrument Cluster Gauge Inoperative in this section.</p>	
3	<p>Disconnect the brake fluid level switch harness connector. Does the park brake/fluid warning/rollaway reminder indicator remain on? Yes – GO to Step 4. No – INSTALL a new brake fluid level switch. OPERATE the system to verify the repair.</p>	Brake Fluid Level Switch
4	<p>Disconnect the park brake switch. Does the park brake/fluid warning/rollaway reminder indicator remain on? Yes – GO to Step 5. No – INSTALL a new park brake switch. OPERATE the system to verify the repair.</p>	
5	<p>Connect a DVOM between the brake fluid level switch</p>	Brake Fluid Level

Step	Action	Connector End View
	harness connector terminal 1 and terminal 3. Does the DVOM display approximately 6 volts? Yes – GO to Step 7. No – GO to Step 6.	Switch
6	<ol style="list-style-type: none"> 1. Disconnect the instrument cluster gauge harness connector J8. 2. Connect a DVOM between the instrument cluster gauge harness connector J8 terminal 8 and the brake fluid level switch harness connector terminal 1. 3. Connect a DVOM between the instrument cluster gauge harness connector J8 terminal 9 and the brake fluid level switch harness connector terminal 3. Does continuity exist? Yes – INSTALL a new instrument cluster gauge. REFER to Instrument Cluster Gauge in this section. OPERATE the system to verify the repair. No – REPAIR circuit 7 or circuit 8. OPERATE the system to verify the repair.	Instrument Cluster Gauge – J8 Brake Fluid Level Switch
7	<ol style="list-style-type: none"> 1. Reconnect the instrument cluster gauge harness connector J8. 2. Connect a DVOM between the park brake switch harness connector terminal 1 and terminal 2. Does the DVOM display approximately 3 volts? Yes – INSTALL a new instrument cluster gauge. REFER to Instrument Cluster Gauge in this section. OPERATE the system to verify the repair. No – GO to Step 8.	Park Brake Switch
8	<ol style="list-style-type: none"> 1. Disconnect the instrument cluster gauge harness connector J8. 2. Connect a DVOM between the instrument cluster gauge harness connector J8 terminal 1 and the park brake switch harness connector terminal 1. 3. Connect a DVOM between the instrument cluster gauge harness connector J8 terminal 2 and the park brake switch harness connector terminal 2. 	Instrument Cluster Gauge – J8 Park Brake Switch

Step	Action	Connector End View
	<p>Does continuity exist?</p> <p>Yes – INSTALL a new instrument cluster gauge. REFER to Instrument Cluster Gauge in this section. OPERATE the system to verify the repair.</p> <p>No – REPAIR circuit 37 or circuit 38. OPERATE the system to verify the repair.</p>	

Park Brake/ Rollaway Reminder Chime Inoperative

Step	Action	Connector End View
1	<p>Did you read the Circuit Description and Operation?</p> <p>Yes – GO to Step 2.</p> <p>No - REFER to Circuit Description and Operation in this section.</p>	
2	<p>1. Set the park brake.</p> <p>2. Place the drive mode selector switch in the Reverse, Turf or Drive position.</p> <p>Does the instrument cluster gauge backlighting illuminate?</p> <p>Yes – GO to Step 3.</p> <p>No – REFER to Instrument Cluster Gauge Inoperative in this section.</p>	
3	<p>Place the drive mode selector switch in the Reverse position.</p> <p>Does the park brake/rollaway reminder chime sound?</p> <p>Yes – GO to Step 4.</p> <p>No – INSTALL a new instrument cluster gauge. REFER to Instrument Cluster Gauge in this section. OPERATE the system to verify the repair.</p>	
4	<p>1. Disengage the park brake.</p> <p>2. Hold the service brake and place the drive mode selector switch in the OFF position.</p> <p>Does the park brake/rollaway reminder chime sound for</p>	

Step	Action	Connector End View
	10 seconds and then stop? Yes – The system is OK. No – GO to Step 5.	
5	1. Disconnect the instrument cluster gauge harness connector J8. 2. Disconnect the park brake switch harness connector. 3. Connect a DVOM between the instrument cluster gauge harness connector J8 terminal 1 and the park brake switch harness connector terminal 2. Does continuity exist? Yes – REPAIR circuit 37 or 38. OPERATE the system to verify the repair. No – INSTALL a new instrument cluster gauge. REFER to Instrument Cluster Gauge in this section. OPERATE the system to verify the repair.	

Motor and Motor Controller

Circuit Description and Operation

With the drive mode selector switch in the Reverse, Turf or Drive position, the motor controller uses inputs from the instrument cluster gauge and the accelerator potentiometer to control motor function. The motor controller varies current flow (direction and intensity) in response to these inputs to allow forward vehicle movement with the drive mode selector switch in the Turf or Drive position, and reverse vehicle movement with the drive mode selector switch in the Reverse position. The motor tachometer/speed sensor sends a signal to the instrument cluster gauge, which displays the vehicle speed.

The following safety features may affect the motor and motor controller operation:

- If the motor temperature exceeds 302 degrees F (150 degrees C), the motor controller will limit current to the motor (armature current) and vehicle performance may seem sluggish.
- If the GFCI cord is connected to the charger, the motor and motor controller will be inoperative.

Circuit Schematic

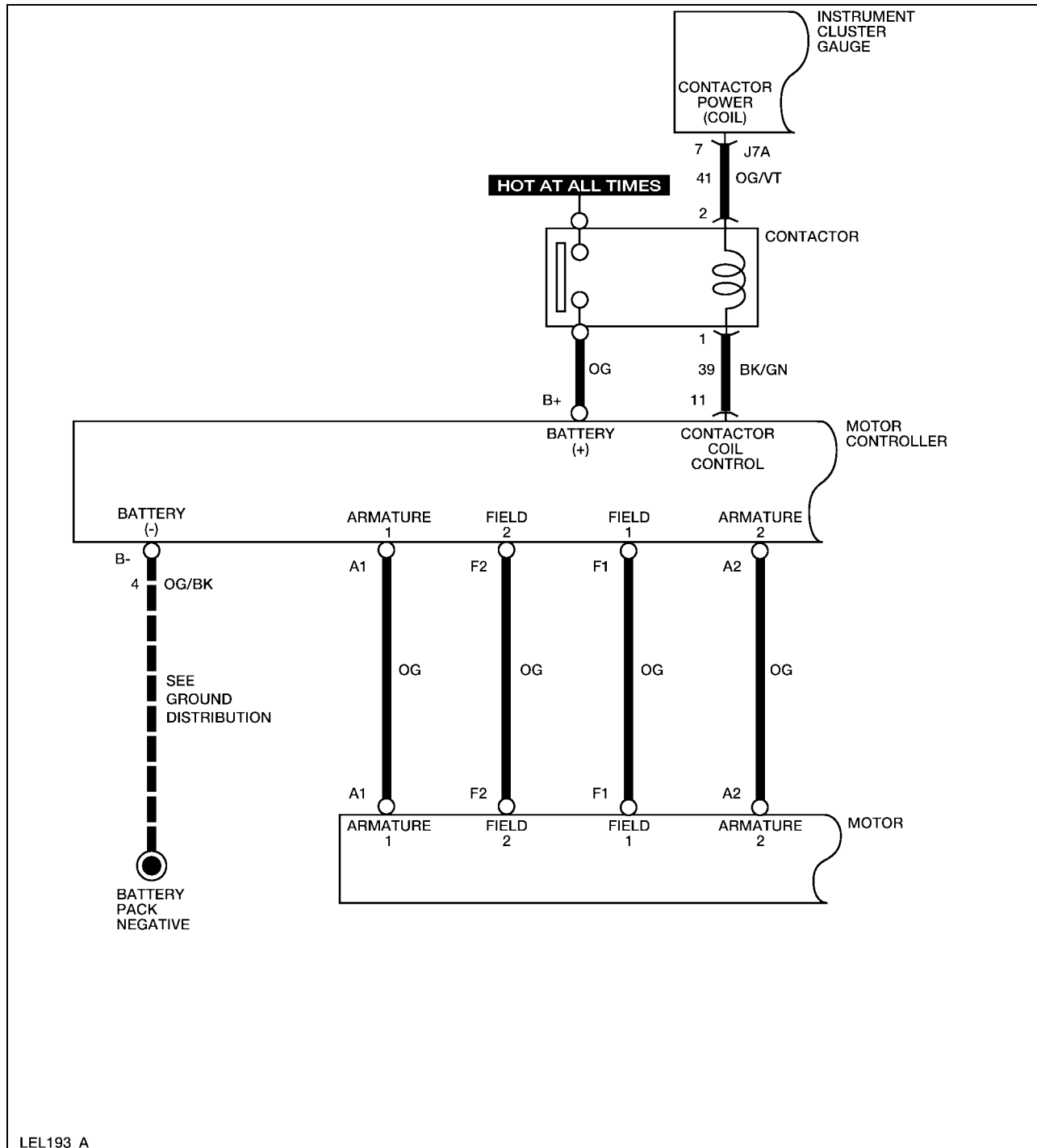

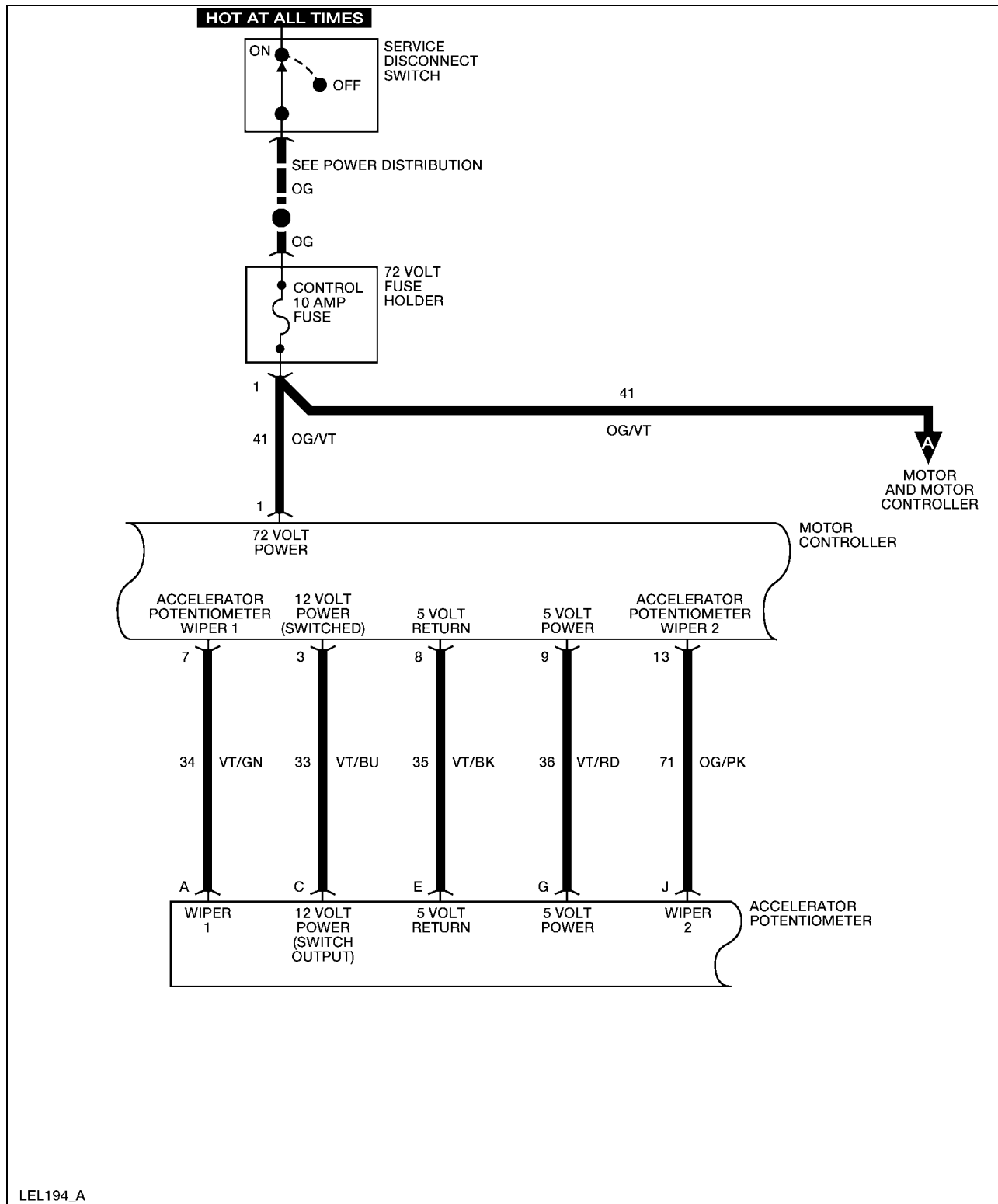

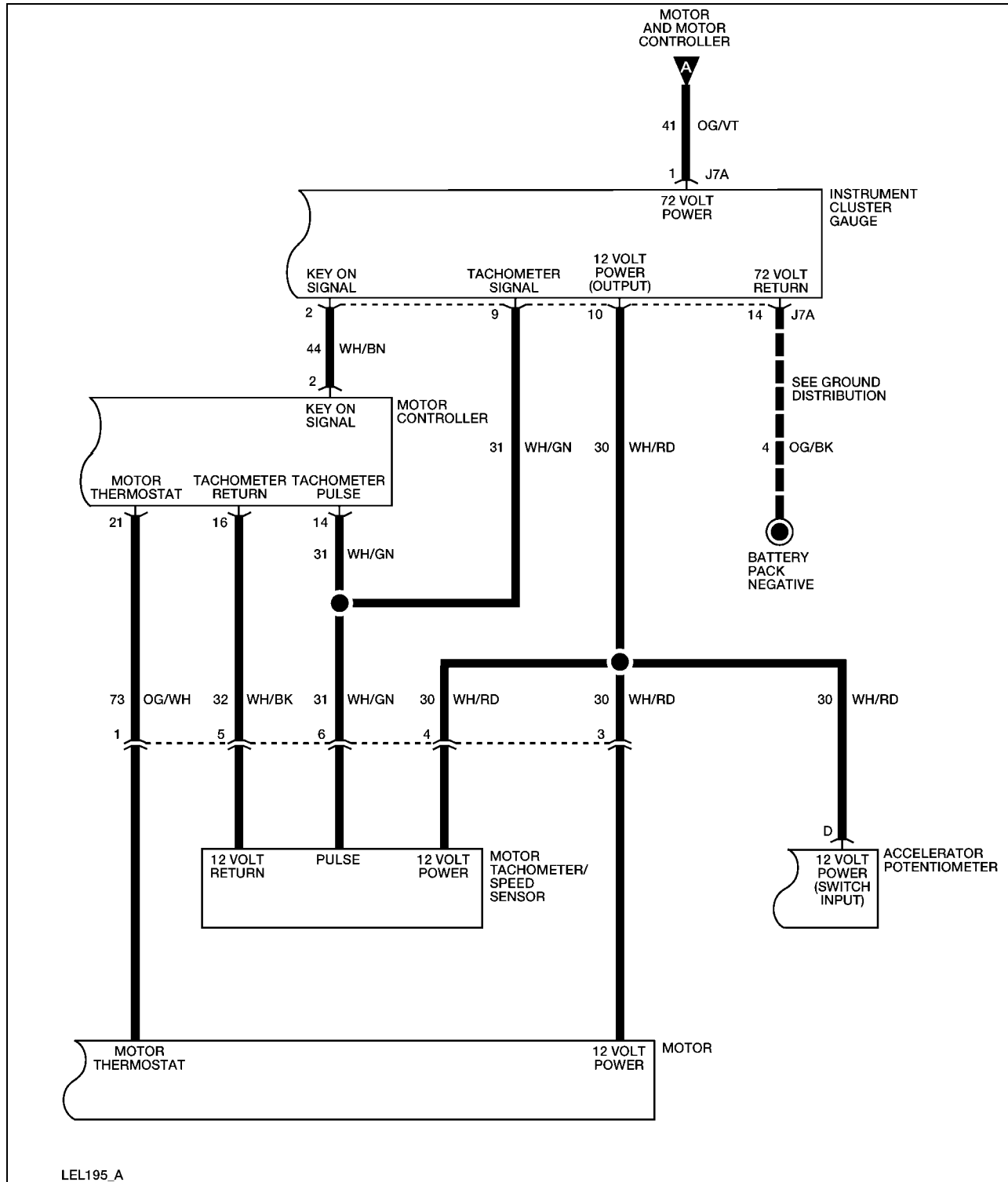

Required Tools

High Voltage Insulated Gloves	100-F036 or equivalent
Face Shield	100-F035 or equivalent

System Check

Functional components in the motor and motor controller system are:

- Service disconnect switch
- Contactor coil
- Control fuse
- Motor
- Motor controller
- Motor tachometer/speed sensor
- Instrument cluster gauge
- Accelerator potentiometer

Guidelines to diagnose the motor and motor controller system:

1. Verify the concern.
2. Check the fuse(s).
3. Check all connectors and related wiring for partially seated terminals, connectors not mating properly and for dirt, moisture or corrosion. For proper contact, terminal(s) must be free of all foreign material.
4. Check for any diagnostic trouble codes. Refer to [Retrieving and Clearing DTCs](#).

If the concern still exists, refer to the following table:

Symptom Chart

Symptom	Possible Causes	Action
Incorrect vehicle speed is displayed on the instrument cluster gauge	<ul style="list-style-type: none"> • Motor tachometer/speed sensor • Instrument cluster gauge • Connectors and related wiring 	GO to Instrument Cluster Gauge Does Not Display Correct Vehicle Speed.

Instrument Cluster Gauge Does Not Display Correct Vehicle Speed

WARNING:

THE BATTERY PACK ASSEMBLY CAN DELIVER IN EXCESS OF 72 VOLTS OF DC POWER. IMPROPER HANDLING OF THE BATTERY PACK CAN RESULT IN INJURY OR FATALITY. ONLY AUTHORIZED PERSONNEL TRAINED TO WORK WITH BATTERY PACK COMPONENTS ARE PERMITTED TO HANDLE THE BATTERIES.

WARNING:

THE BATTERY PACK CONTAINS HIGH-VOLTAGE COMPONENTS AND WIRING. HIGH-VOLTAGE INSULATED SAFETY GLOVES AND FACE SHIELD MUST BE WORN WHEN PERFORMING THE FOLLOWING STEPS. FAILURE TO FOLLOW THIS WARNING MAY RESULT IN SEVERE PERSONAL INJURY OR DEATH.

Step	Action	Connector End View
1	Did you read the Circuit Description and Operation? Yes - GO to Step 2. No - REFER to Circuit Description and Operation.	
2	<ol style="list-style-type: none"> 1. Raise the vehicle on a hoist. 2. Disconnect the motor controller harness connector. 3. Connect a fused jumper wire between the motor controller harness connector terminal 16 and the battery pack negative. 4. Connect a DVOM between the motor controller harness connector terminal 16 and terminal 14. 5. Place the drive mode selector switch in the Drive position. 6. Slowly rotate both rear vehicle wheels in the same direction. 	Motor Controller

Step	Action	Connector End View
	<p>(This will cause the motor to rotate.)</p> <p>Does the voltage alternate between approximately 1 volt and 10 volts?</p> <p>Yes – GO to Step 3.</p> <p>No – GO to Step 5.</p>	
3	<p>Observe the instrument cluster gauge while rotating both rear vehicle wheels in the same direction.</p> <p>Does the speed indication on the instrument cluster gauge change?</p> <p>Yes – The system is OK.</p> <p>No – GO to Step 4.</p>	
4	<ol style="list-style-type: none"> 1. Disconnect the instrument cluster gauge harness connector J7A. 2. Disconnect the motor tachometer/speed sensor harness connector. 3. Connect a DVOM between the instrument cluster connector J7A terminal 9 and motor tachometer/speed sensor connector terminal 6. <p>Does continuity exist?</p> <p>Yes – INSTALL a new instrument cluster gauge. REFER to Instrument Cluster Gauge in this section. OPERATE the system to verify the repair.</p> <p>No – REPAIR circuit 31. OPERATE the system to verify the repair.</p>	<p>Instrument Cluster Gauge – J7A</p> <p>Motor Tachometer/Speed Sensor</p>
5	<ol style="list-style-type: none"> 1. Disconnect the motor tachometer/speed sensor harness connector. 2. Connect a DVOM between the motor tachometer/speed sensor harness connector terminal 4 and the battery pack negative. <p>Does the DVOM display approximately 12 volts?</p> <p>Yes – GO to Step 6.</p> <p>No – GO to Step 7.</p>	<p>Motor Tachometer/Speed Sensor</p>
6	<ol style="list-style-type: none"> 1. Connect a DVOM between the motor controller harness connector terminal 16 and the motor tachometer/speed sensor harness connector terminal 5. 	<p>Motor Controller</p> <p>Motor Tachometer/Speed</p>

Step	Action	Connector End View
	<p>2. Connect a DVOM between the motor controller harness connector terminal 14 and the motor tachometer/speed sensor harness connector terminal 6.</p> <p>Does continuity exist?</p> <p>Yes – INSTALL a new motor tachometer/speed sensor. REFER to Motor Tachometer/Speed Sensor in the powertrain section. OPERATE the system to verify the repair.</p> <p>No – REPAIR circuit 31 or circuit 32. OPERATE the system to verify the repair.</p>	Sensor
7	<p>1. Disconnect the instrument cluster gauge harness connector J7A.</p> <p>2. Connect a DVOM between the instrument cluster harness connector J7A terminal 10 and the motor tachometer/speed sensor harness connector terminal 4.</p> <p>Does continuity exist?</p> <p>Yes – INSTALL a new instrument cluster gauge. REFER to Instrument Cluster Gauge in this section. OPERATE the system to verify the repair.</p> <p>No – REPAIR circuit 30. OPERATE the system to verify the repair.</p>	Instrument Cluster Gauge – J7A Motor Tachometer/Speed Sensor

DTC 21

Description:

Accelerator voltage is too high.

Symptom:

Motor controller will not operate.

Possible cause(s):

- Accelerator potentiometer
- Connectors and related wiring
- Motor controller

WARNING:

THE BATTERY PACK ASSEMBLY CAN DELIVER IN EXCESS OF 72 VOLTS OF DC POWER. IMPROPER HANDLING OF THE BATTERY PACK CAN RESULT IN INJURY OR FATALITY. ONLY AUTHORIZED PERSONNEL TRAINED TO WORK WITH BATTERY PACK COMPONENTS ARE PERMITTED TO HANDLE THE BATTERIES.

WARNING:

THE BATTERY PACK CONTAINS HIGH-VOLTAGE COMPONENTS AND WIRING. HIGH-VOLTAGE INSULATED SAFETY GLOVES AND FACE SHIELD MUST BE WORN WHEN PERFORMING THE FOLLOWING STEPS. FAILURE TO FOLLOW THIS WARNING MAY RESULT IN SEVERE PERSONAL INJURY OR DEATH.

Step	Action	Connector End View
1.	Did you perform the Diagnostic System Check? Yes - GO to Step 2. No - REFER to Diagnostic System Check in this section.	
2.	<ol style="list-style-type: none"> 1. Disconnect the motor controller harness connector and the accelerator potentiometer harness connector. 2. Connect a DVOM between the motor controller harness connector terminal 7 and the accelerator potentiometer harness connector terminal A. 3. Connect a DVOM between the motor controller harness connector terminal 8 and the accelerator potentiometer harness connector terminal E. 4. Connect a DVOM between the motor controller harness connector terminal 9 and the accelerator potentiometer harness connector terminal G. 5. Connect a DVOM between the motor controller harness connector terminal 13 and the accelerator potentiometer harness connector terminal J. Does continuity exist? Yes - GO to Step 3. No – INSTALL a new 72 volt harness. REFER to Wiring Harnesses in this section. OPERATE the system to verify the repair.	Motor Controller Accelerator Potentiometer
3.	Connect a DVOM between the motor controller terminal 7	Motor Controller

Step	Action	Connector End View
	<p>and the vehicle chassis.</p> <p>Does the DVOM display greater than approximately 1.25 volts?</p> <p>Yes - INSTALL a new motor controller. REFER to Motor Controller in the Powertrain section. OPERATE the system to verify the repair.</p> <p>No – INSTALL a new accelerator potentiometer. REFER to Accelerator Potentiometer in the Powertrain section. OPERATE the system to verify the repair.</p>	

DTC 23

Description:

Motor field current is high at start up in the reverse direction.

Symptom:

Motor controller will not operate.

Possible cause(s):

- Motor controller.

WARNING:

THE BATTERY PACK ASSEMBLY CAN DELIVER IN EXCESS OF 72 VOLTS OF DC POWER. IMPROPER HANDLING OF THE BATTERY PACK CAN RESULT IN INJURY OR FATALITY. ONLY AUTHORIZED PERSONNEL TRAINED TO WORK WITH BATTERY PACK COMPONENTS ARE PERMITTED TO HANDLE THE BATTERIES.

WARNING:

THE BATTERY PACK CONTAINS HIGH-VOLTAGE COMPONENTS AND WIRING. HIGH-VOLTAGE INSULATED SAFETY GLOVES AND FACE SHIELD MUST BE WORN WHEN PERFORMING THE FOLLOWING STEPS. FAILURE TO FOLLOW THIS WARNING MAY RESULT IN SEVERE PERSONAL INJURY OR DEATH.

Step	Action	Connector End View
1	<p>Did you perform the Diagnostic System Check?</p> <p>Yes – INSTALL a new motor controller. REFER to Motor Controller in the Powertrain section. OPERATE the system to verify the repair.</p> <p>No - REFER to Diagnostic System Check.</p>	

DTC 24

Description:

Motor field current is high at start up in the forward direction.

Symptom:

Motor controller will not operate.

Possible cause(s):

- Motor controller.

WARNING:

THE BATTERY PACK ASSEMBLY CAN DELIVER IN EXCESS OF 72 VOLTS OF DC POWER. IMPROPER HANDLING OF THE BATTERY PACK CAN RESULT IN INJURY OR FATALITY. ONLY AUTHORIZED PERSONNEL TRAINED TO WORK WITH BATTERY PACK COMPONENTS ARE PERMITTED TO HANDLE THE BATTERIES.

WARNING:

THE BATTERY PACK CONTAINS HIGH-VOLTAGE COMPONENTS AND WIRING. HIGH-VOLTAGE INSULATED SAFETY GLOVES AND FACE SHIELD MUST BE WORN WHEN PERFORMING THE FOLLOWING STEPS. FAILURE TO FOLLOW THIS WARNING MAY RESULT IN SEVERE PERSONAL INJURY OR DEATH.

Step	Action	Connector End View
1	<p>Did you perform the Diagnostic System Check?</p> <p>Yes – INSTALL a new motor controller. REFER to Motor Controller in the Powertrain section.</p>	

Step	Action	Connector End View
	No – REFER to Diagnostic System Check .	

DTC 27

Description:

12 volt bus is too low.

Symptom:

Motor controller will not operate.

Possible cause(s):

- Motor controller.

WARNING:

THE BATTERY PACK ASSEMBLY CAN DELIVER IN EXCESS OF 72 VOLTS OF DC POWER. IMPROPER HANDLING OF THE BATTERY PACK CAN RESULT IN INJURY OR FATALITY. ONLY AUTHORIZED PERSONNEL TRAINED TO WORK WITH BATTERY PACK COMPONENTS ARE PERMITTED TO HANDLE THE BATTERIES.

WARNING:

THE BATTERY PACK CONTAINS HIGH-VOLTAGE COMPONENTS AND WIRING. HIGH-VOLTAGE INSULATED SAFETY GLOVES AND FACE SHIELD MUST BE WORN WHEN PERFORMING THE FOLLOWING STEPS. FAILURE TO FOLLOW THIS WARNING MAY RESULT IN SEVERE PERSONAL INJURY OR DEATH.

Step	Action	Connector End View
1	<p>Did you perform the Diagnostic System Check?</p> <p>Yes - INSTALL a new motor controller. REFER to Motor Controller in the Powertrain section. OPERATE the system to verify the repair.</p> <p>No - REFER to Diagnostic System Check.</p>	

DTC 41

Description:

Open thermal protector (TP) or transistor over-temperature.

Symptom:

Reduced or no power to traction motor.

Possible cause(s):

- Motor controller is in thermal cutback due to high temperature.
- Motor controller.

WARNING:

THE BATTERY PACK ASSEMBLY CAN DELIVER IN EXCESS OF 72 VOLTS OF DC POWER. IMPROPER HANDLING OF THE BATTERY PACK CAN RESULT IN INJURY OR FATALITY. ONLY AUTHORIZED PERSONNEL TRAINED TO WORK WITH BATTERY PACK COMPONENTS ARE PERMITTED TO HANDLE THE BATTERIES.

WARNING:

THE BATTERY PACK CONTAINS HIGH-VOLTAGE COMPONENTS AND WIRING. HIGH-VOLTAGE INSULATED SAFETY GLOVES AND FACE SHIELD MUST BE WORN WHEN PERFORMING THE FOLLOWING STEPS. FAILURE TO FOLLOW THIS WARNING MAY RESULT IN SEVERE PERSONAL INJURY OR DEATH.

Step	Action	Connector End View
1	Did you perform the Diagnostic System Check? Yes - GO to Step 2. No - REFER to Diagnostic System Check .	
2	1. Allow the motor to cool to ambient temperature. 2. Clear the DTC. Refer to Retrieving and Clearing DTCs. 3. Drive the vehicle. 4. Check for DTCs. Refer to Retrieving and Clearing DTCs. Does DTC 41 set again? Yes - INSTALL a new motor controller. REFER to Motor	

Step	Action	Connector End View
	<p>Controller in the Powertrain section. OPERATE the system to verify the repair.</p> <p>No – The system is OK.</p>	

DTC 42

Description:

Motor armature offset voltage is too high.

Symptom:

Motor controller will not operate.

Possible cause(s):

- Motor controller.

WARNING:

THE BATTERY PACK ASSEMBLY CAN DELIVER IN EXCESS OF 72 VOLTS OF DC POWER. IMPROPER HANDLING OF THE BATTERY PACK CAN RESULT IN INJURY OR FATALITY. ONLY AUTHORIZED PERSONNEL TRAINED TO WORK WITH BATTERY PACK COMPONENTS ARE PERMITTED TO HANDLE THE BATTERIES.

WARNING:

THE BATTERY PACK CONTAINS HIGH-VOLTAGE COMPONENTS AND WIRING. HIGH-VOLTAGE INSULATED SAFETY GLOVES AND FACE SHIELD MUST BE WORN WHEN PERFORMING THE FOLLOWING STEPS. FAILURE TO FOLLOW THIS WARNING MAY RESULT IN SEVERE PERSONAL INJURY OR DEATH.

Step	Action	Connector End View
1	<p>Did you perform the Diagnostic System Check?</p> <p>Yes - INSTALL a new motor controller. REFER to Motor Controller in the Powertrain section. OPERATE the system to verify the repair.</p> <p>No - REFER to Diagnostic System Check.</p>	

DTC 43

Description:

Motor armature offset voltage is too low.

Symptom:

Motor controller will not operate.

Possible cause(s):

- Motor controller.

WARNING:

THE BATTERY PACK ASSEMBLY CAN DELIVER IN EXCESS OF 72 VOLTS OF DC POWER. IMPROPER HANDLING OF THE BATTERY PACK CAN RESULT IN INJURY OR FATALITY. ONLY AUTHORIZED PERSONNEL TRAINED TO WORK WITH BATTERY PACK COMPONENTS ARE PERMITTED TO HANDLE THE BATTERIES.

WARNING:

THE BATTERY PACK CONTAINS HIGH-VOLTAGE COMPONENTS AND WIRING. HIGH-VOLTAGE INSULATED SAFETY GLOVES AND FACE SHIELD MUST BE WORN WHEN PERFORMING THE FOLLOWING STEPS. FAILURE TO FOLLOW THIS WARNING MAY RESULT IN SEVERE PERSONAL INJURY OR DEATH.

Step	Action	Connector End View
1	Did you perform the Diagnostic System Check? Yes - INSTALL a new motor controller. REFER to Motor Controller in the Powertrain section. OPERATE the system to verify the repair. No - REFER to Diagnostic System Check .	

DTC 44

Description:

Armature transistor did not turn off properly.

Symptom:

Motor controller will not operate.

Possible cause(s):

- Motor controller.

WARNING:

THE BATTERY PACK ASSEMBLY CAN DELIVER IN EXCESS OF 72 VOLTS OF DC POWER. IMPROPER HANDLING OF THE BATTERY PACK CAN RESULT IN INJURY OR FATALITY. ONLY AUTHORIZED PERSONNEL TRAINED TO WORK WITH BATTERY PACK COMPONENTS ARE PERMITTED TO HANDLE THE BATTERIES.

WARNING:

THE BATTERY PACK CONTAINS HIGH-VOLTAGE COMPONENTS AND WIRING. HIGH-VOLTAGE INSULATED SAFETY GLOVES AND FACE SHIELD MUST BE WORN WHEN PERFORMING THE FOLLOWING STEPS. FAILURE TO FOLLOW THIS WARNING MAY RESULT IN SEVERE PERSONAL INJURY OR DEATH.

Step	Action	Connector End View
1	Did you perform the Diagnostic System Check? Yes - INSTALL a new motor controller. REFER to Motor Controller in the Powertrain section. OPERATE the system to verify the repair. No - REFER to Diagnostic System Check .	

DTC 45

Description:

Armature transistor did not turn on properly.

Symptom:

Motor controller will not operate.

Possible cause(s):

- Motor controller.

WARNING:

THE BATTERY PACK ASSEMBLY CAN DELIVER IN EXCESS OF 72 VOLTS OF DC POWER. IMPROPER HANDLING OF THE BATTERY PACK CAN RESULT IN INJURY OR FATALITY. ONLY AUTHORIZED PERSONNEL TRAINED TO WORK WITH BATTERY PACK COMPONENTS ARE PERMITTED TO HANDLE THE BATTERIES.

WARNING:

THE BATTERY PACK CONTAINS HIGH-VOLTAGE COMPONENTS AND WIRING. HIGH-VOLTAGE INSULATED SAFETY GLOVES AND FACE SHIELD MUST BE WORN WHEN PERFORMING THE FOLLOWING STEPS. FAILURE TO FOLLOW THIS WARNING MAY RESULT IN SEVERE PERSONAL INJURY OR DEATH.

Step	Action	Connector End View
1	Did you perform the Diagnostic System Check? Yes - INSTALL a new motor controller. REFER to Motor Controller in the Powertrain section. OPERATE the system to verify the repair. No - REFER to Diagnostic System Check .	

DTC 46

Description:

“Look Ahead” test for A2 voltage is less than 12% of battery voltage.

Symptom:

Motor controller will not operate.

Possible cause(s):

- Motor controller.

WARNING:

THE BATTERY PACK ASSEMBLY CAN DELIVER IN EXCESS OF 72 VOLTS OF DC POWER. IMPROPER HANDLING OF THE BATTERY PACK CAN RESULT IN INJURY OR FATALITY. ONLY AUTHORIZED PERSONNEL TRAINED TO WORK WITH BATTERY PACK COMPONENTS ARE PERMITTED TO HANDLE THE BATTERIES.

WARNING:

THE BATTERY PACK CONTAINS HIGH-VOLTAGE COMPONENTS AND WIRING. HIGH-VOLTAGE INSULATED SAFETY GLOVES AND FACE SHIELD MUST BE WORN WHEN PERFORMING THE FOLLOWING STEPS. FAILURE TO FOLLOW THIS WARNING MAY RESULT IN SEVERE PERSONAL INJURY OR DEATH.

Step	Action	Connector End View
1	Did you perform the Diagnostic System Check? Yes – INSTALL a new motor controller. REFER to Motor Controller in the Powertrain section. OPERATE the system to verify the repair. No - REFER to Diagnostic System Check .	

DTC 49

Description:

Motor field current is too low during the run mode.

Symptom:

Motor controller will not operate.

Possible cause(s):

- Motor.
- Motor controller.

WARNING:

THE BATTERY PACK ASSEMBLY CAN DELIVER IN EXCESS OF 72 VOLTS OF DC POWER. IMPROPER HANDLING OF THE BATTERY PACK CAN RESULT IN INJURY OR FATALITY. ONLY AUTHORIZED PERSONNEL TRAINED TO WORK WITH BATTERY PACK COMPONENTS ARE PERMITTED TO HANDLE THE BATTERIES.

WARNING:

THE BATTERY PACK CONTAINS HIGH-VOLTAGE COMPONENTS AND WIRING. HIGH-VOLTAGE INSULATED SAFETY GLOVES AND FACE SHIELD MUST BE WORN WHEN PERFORMING THE FOLLOWING STEPS. FAILURE TO FOLLOW THIS WARNING MAY RESULT IN SEVERE PERSONAL INJURY OR DEATH.

Step	Action	Connector End View
1	Did you perform the Diagnostic System Check? Yes - GO to Step 2. No - REFER to Diagnostic System Check .	
2	1. Disconnect the motor field connections at the motor. 2. Connect a DVOM between the motor field terminals. Does continuity exist? Yes - INSTALL a new motor controller. REFER to Motor Controller in the Powertrain section. OPERATE the system to verify the repair. No - INSTALL a new motor. REFER to Motor in the	

Step	Action	Connector End View
	Powertrain section. OPERATE the system to verify the repair.	

DTC 51

Description:

Capacitor voltage is low before the line contactor closes.

Symptom:

Motor controller will not operate.

Possible cause(s):

- Motor controller.

WARNING:

THE BATTERY PACK ASSEMBLY CAN DELIVER IN EXCESS OF 72 VOLTS OF DC POWER. IMPROPER HANDLING OF THE BATTERY PACK CAN RESULT IN INJURY OR FATALITY. ONLY AUTHORIZED PERSONNEL TRAINED TO WORK WITH BATTERY PACK COMPONENTS ARE PERMITTED TO HANDLE THE BATTERIES.

WARNING:

THE BATTERY PACK CONTAINS HIGH-VOLTAGE COMPONENTS AND WIRING. HIGH-VOLTAGE INSULATED SAFETY GLOVES AND FACE SHIELD MUST BE WORN WHEN PERFORMING THE FOLLOWING STEPS. FAILURE TO FOLLOW THIS WARNING MAY RESULT IN SEVERE PERSONAL INJURY OR DEATH.

Step	Action	Connector End View
1	Did you perform the Diagnostic System Check? Yes - INSTALL a new motor controller. REFER to Motor Controller in the Powertrain section. OPERATE the system to verify the repair. No - REFER to Diagnostic System Check .	

DTC 57

Description:

Controller “motor current sensor” input too low while running.

Symptom:

Motor controller will not operate.

Possible cause(s):

- Motor controller.

WARNING:

THE BATTERY PACK ASSEMBLY CAN DELIVER IN EXCESS OF 72 VOLTS OF DC POWER. IMPROPER HANDLING OF THE BATTERY PACK CAN RESULT IN INJURY OR FATALITY. ONLY AUTHORIZED PERSONNEL TRAINED TO WORK WITH BATTERY PACK COMPONENTS ARE PERMITTED TO HANDLE THE BATTERIES.

WARNING:

THE BATTERY PACK CONTAINS HIGH-VOLTAGE COMPONENTS AND WIRING. HIGH-VOLTAGE INSULATED SAFETY GLOVES AND FACE SHIELD MUST BE WORN WHEN PERFORMING THE FOLLOWING STEPS. FAILURE TO FOLLOW THIS WARNING MAY RESULT IN SEVERE PERSONAL INJURY OR DEATH.

Step	Action	Connector End View
1	Did you perform the Diagnostic System Check? Yes - INSTALL a new motor controller. REFER to Motor Controller in the Powertrain section. OPERATE the system to verify the repair. No - REFER to the Diagnostic System Check .	

DTC 66

Description:

The field current exceeds the current limit of the field transistor.

Symptom:

Control will not operate or is sluggish on start up. Line contactor opens.

Possible cause(s):

- Motor field circuits shorted.
- Binding line contactor.
- Motor over-temperature condition.
- Motor thermal fuse.
- Motor controller.

WARNING:

THE BATTERY PACK ASSEMBLY CAN DELIVER IN EXCESS OF 72 VOLTS OF DC POWER. IMPROPER HANDLING OF THE BATTERY PACK CAN RESULT IN INJURY OR FATALITY. ONLY AUTHORIZED PERSONNEL TRAINED TO WORK WITH BATTERY PACK COMPONENTS ARE PERMITTED TO HANDLE THE BATTERIES.

WARNING:

THE BATTERY PACK CONTAINS HIGH-VOLTAGE COMPONENTS AND WIRING. HIGH-VOLTAGE INSULATED SAFETY GLOVES AND FACE SHIELD MUST BE WORN WHEN PERFORMING THE FOLLOWING STEPS. FAILURE TO FOLLOW THIS WARNING MAY RESULT IN SEVERE PERSONAL INJURY OR DEATH.

Step	Action	Connector End View
1.	Did you perform the Diagnostic System Check? Yes – GO to Step 2. No - REFER to the Diagnostic System Check .	
2.	1. Disconnect the motor field connections at the motor. 2. Connect a DVOM between the motor field terminals. Does the DVOM display approximately 1.3 ohms?	Motor

Step	Action	Connector End View
	<p>Yes – GO to Step 3.</p> <p>No – INSTALL a new motor. REFER to Motor in the Powertrain section. OPERATE the system to verify the repair.</p>	
3.	<ol style="list-style-type: none"> 1. Disconnect the motor field connections at the motor controller. 2. Connect a DVOM between motor F1 and motor controller F1. 3. Connect a DVOM between motor F2 and motor controller F2. <p>Does continuity exist?</p> <p>Yes – GO to Step 4.</p> <p>No – REPAIR open in field cable. OPERATE the system to verify the repair.</p>	
4.	<ol style="list-style-type: none"> 1. Connect a DVOM between motor F1 and the vehicle chassis. 2. Connect a DVOM between motor F2 and the vehicle chassis. <p>Does continuity exist?</p> <p>Yes – REPAIR field cable short to ground. OPERATE the system to verify the repair.</p> <p>No – INSTALL a new motor controller. REFER to Motor Controller in the Powertrain section. OPERATE the system to verify the repair.</p>	

DTC 76

Description:

Capacitor 1C voltage too high during regenerative braking.

Symptom:

Motor controller will not operate.

Possible cause(s):

- Motor controller.

WARNING:

THE BATTERY PACK ASSEMBLY CAN DELIVER IN EXCESS OF 72 VOLTS OF DC POWER. IMPROPER HANDLING OF THE BATTERY PACK CAN RESULT IN INJURY OR FATALITY. ONLY AUTHORIZED PERSONNEL TRAINED TO WORK WITH BATTERY PACK COMPONENTS ARE PERMITTED TO HANDLE THE BATTERIES.

WARNING:

THE BATTERY PACK CONTAINS HIGH-VOLTAGE COMPONENTS AND WIRING. HIGH-VOLTAGE INSULATED SAFETY GLOVES AND FACE SHIELD MUST BE WORN WHEN PERFORMING THE FOLLOWING STEPS. FAILURE TO FOLLOW THIS WARNING MAY RESULT IN SEVERE PERSONAL INJURY OR DEATH.

Step	Action	Connector End View
1.	Did you perform the Diagnostic System Check? Yes - INSTALL a new motor controller. REFER to Motor Controller in the Powertrain section. OPERATE the system to verify the repair. No - REFER to the Diagnostic System Check .	

DTC 77

Description:

Capacitor 1C voltage too high during motoring.

Symptom:

Motor controller will not operate.

Possible cause(s):

- Motor controller.

WARNING:

THE BATTERY PACK ASSEMBLY CAN DELIVER IN EXCESS OF 72 VOLTS OF DC POWER. IMPROPER HANDLING OF THE BATTERY PACK CAN RESULT IN INJURY OR FATALITY. ONLY AUTHORIZED PERSONNEL TRAINED TO WORK WITH BATTERY PACK COMPONENTS ARE PERMITTED TO HANDLE THE BATTERIES.

WARNING:

THE BATTERY PACK CONTAINS HIGH-VOLTAGE COMPONENTS AND WIRING. HIGH-VOLTAGE INSULATED SAFETY GLOVES AND FACE SHIELD MUST BE WORN WHEN PERFORMING THE FOLLOWING STEPS. FAILURE TO FOLLOW THIS WARNING MAY RESULT IN SEVERE PERSONAL INJURY OR DEATH.

Step	Action	Connector End View
1	Did you perform the Diagnostic System Check? Yes - INSTALL a new motor controller. REFER to Motor Controller in the Powertrain section. OPERATE the system to verify the repair. No - REFER to the Diagnostic System Check .	

DTC 90

Description:

Motor thermostat is open during control operation.

Symptom:

- Over-temp condition has occurred.
- Motor armature current is limited to 100 amps. Vehicle performance is sluggish.

Possible cause(s):

- Motor controller.
- 72 volt harness open.
- Motor over-temperature condition.
- Motor thermal fuse (internal to the motor).
- Instrument cluster gauge.

WARNING:

THE BATTERY PACK ASSEMBLY CAN DELIVER IN EXCESS OF 72 VOLTS OF DC POWER. IMPROPER HANDLING OF THE BATTERY PACK CAN RESULT IN INJURY OR FATALITY. ONLY AUTHORIZED PERSONNEL TRAINED TO WORK WITH BATTERY PACK COMPONENTS ARE PERMITTED TO HANDLE THE BATTERIES.

WARNING:

THE BATTERY PACK CONTAINS HIGH-VOLTAGE COMPONENTS AND WIRING. HIGH-VOLTAGE INSULATED SAFETY GLOVES AND FACE SHIELD MUST BE WORN WHEN PERFORMING THE FOLLOWING STEPS. FAILURE TO FOLLOW THIS WARNING MAY RESULT IN SEVERE PERSONAL INJURY OR DEATH.

Step	Action	Connector End View
1	Did you perform the Diagnostic System Check? Yes - GO to Step 2. No - REFER to Diagnostic System Check .	
2	1. Allow the motor to cool to ambient temperature.	

Step	Action	Connector End View
	2. Clear the DTC. Refer to Retrieving and Clearing DTCs . 3. Drive the vehicle. 4. Check for DTCs. Refer to Retrieving and Clearing DTCs . Does DTC 90 display again? Yes - GO to Step 3. No – The system is OK.	
3	1. Disconnect the motor tachometer/speed sensor harness connector. 2. Connect a DVOM between the motor tachometer/speed sensor harness connector terminal 1 and terminal 3. Does continuity exist? Yes – GO to Step 4. No – INSTALL a new motor. REFER to Motor in the Powertrain section. OPERATE the system to verify the repair.	Motor Tachometer/Speed Sensor
4	1. Set the park brake. 2. Place the drive mode selector switch in the Drive position. 3. Connect a DVOM between the motor tachometer/speed sensor harness connector terminal 3 and the battery pack negative. Does the DVOM display approximately 12 volts? Yes – GO to Step 5. No – GO to Step 6.	Motor Tachometer/Speed Sensor
5	1. Disconnect the motor controller harness connector. 2. Connect a DVOM between the motor controller harness connector terminal 21 and the motor tachometer/speed sensor connector terminal 1. Does continuity exist? Yes – INSTALL a new motor controller. REFER to Motor Controller in the Powertrain section. OPERATE the system to verify the repair. No – REPAIR circuit 73. OPERATE the system to verify the repair.	Motor Controller Motor Tachometer/Speed Sensor
6	1. Place the drive mode selector switch in the OFF position.	Instrument Cluster Gauge – J7A

Step	Action	Connector End View
	<p>2. Disconnect the instrument cluster gauge harness connector J7A.</p> <p>3. Connect a DVOM between the instrument cluster gauge harness connector J7A terminal 10 and the motor tachometer/speed sensor harness connector terminal 3.</p> <p>Does continuity exist?</p> <p>Yes – INSTALL a new instrument cluster gauge. REFER to Instrument Cluster Gauge in this section. OPERATE the system to verify the repair.</p> <p>No – REPAIR circuit 30. OPERATE the system to verify the repair.</p>	<p>Motor Tachometer/Speed Sensor</p>

Power Point

Circuit Description and Operation

72 volt power is applied through the DC/DC fuse to DC/DC converter 2 (optional), then through the power point fuse to the power point. The 12 volt return for the power point is also provided through the DC/DC converter 2 (optional). When an accessory is inserted into the power point, the circuit is complete and power is applied to the accessory.

Circuit Schematic

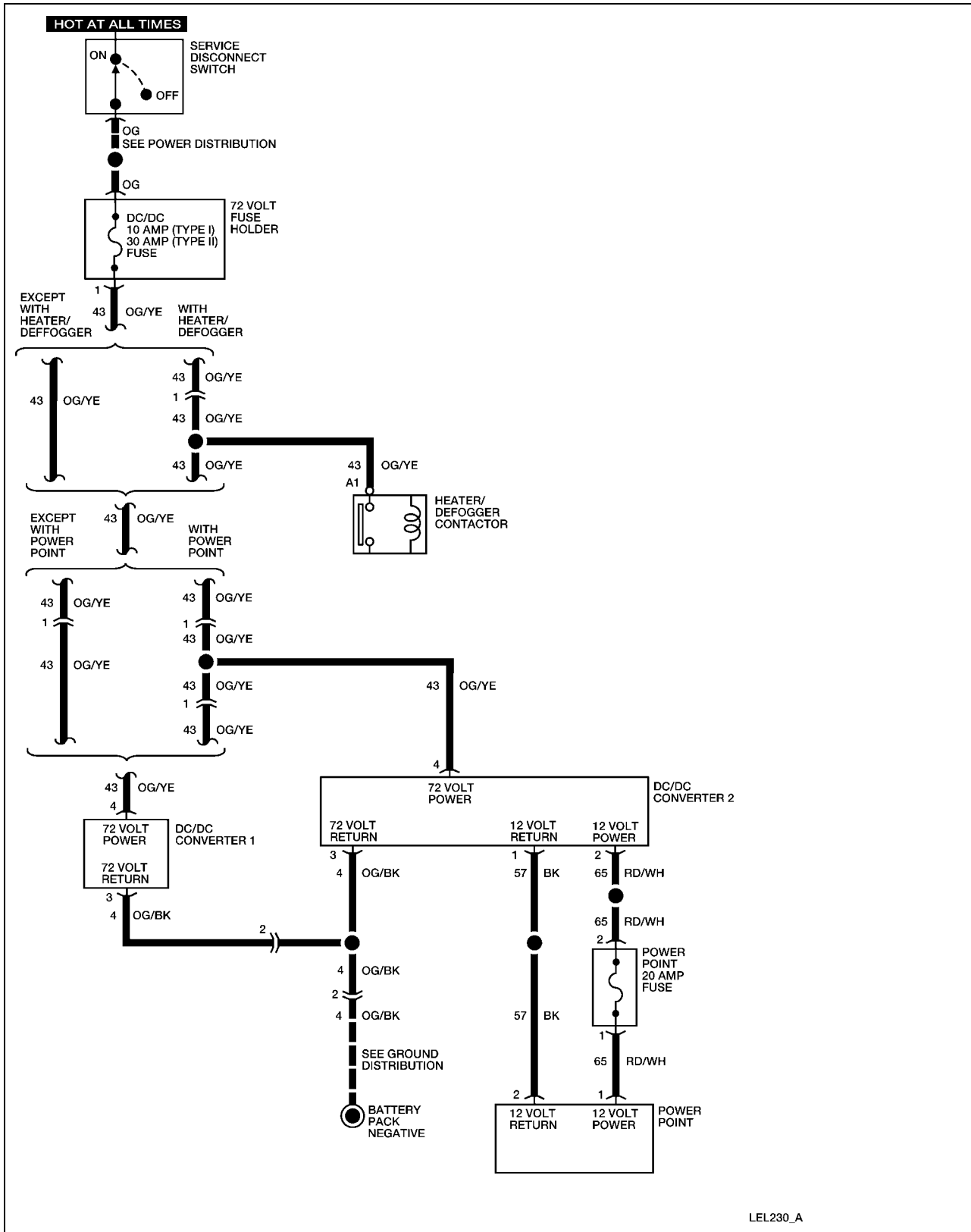

LEL230_A

Required Tools

High Voltage Insulated Gloves	100-F036 or equivalent
Face Shield	100-F035 or equivalent

System Check

Functional components in the power point system are:

- DC/DC fuse
- DC/DC converter 2 (optional)
- Power point fuse
- Power point
- Related wiring

Guidelines to diagnose the power point system:

1. Verify the concern.
2. Check the fuse(s).
3. Check all connectors and related wiring for partially seated terminals, connectors not mating properly and for dirt, moisture or corrosion. For proper contact, terminal(s) must be free of all foreign material.

If the concern still exists, refer to the following table:

Symptom Chart

Symptom	Possible Causes	Action
The power point is inoperative	<ul style="list-style-type: none"> • DC/DC fuse • Power point fuse • Power point • DC/DC converter 2 (optional) • Connectors or related wiring 	GO to Power Point Inoperative.

Power Point Inoperative

WARNING:

THE BATTERY PACK ASSEMBLY CAN DELIVER IN EXCESS OF 72 VOLTS OF DC POWER. IMPROPER HANDLING OF THE BATTERY PACK CAN RESULT IN INJURY OR FATALITY. ONLY AUTHORIZED PERSONNEL TRAINED TO WORK WITH BATTERY PACK COMPONENTS ARE PERMITTED TO HANDLE THE BATTERIES.

WARNING:

THE BATTERY PACK CONTAINS HIGH-VOLTAGE COMPONENTS AND WIRING. HIGH-VOLTAGE INSULATED SAFETY GLOVES AND FACE SHIELD MUST BE WORN WHEN PERFORMING THE FOLLOWING STEPS. FAILURE TO FOLLOW THIS WARNING MAY RESULT IN SEVERE PERSONAL INJURY OR DEATH.

Step	Action	Connector End View
1	Did you read the Circuit Description and Operation? Yes - GO to Step 2. No - REFER to Circuit Description and Operation .	
2	Connect a DVOM between the DC/DC converter 2 (optional) harness connector terminal 1 and terminal 2. Does the DVOM display approximately 12 volts? Yes – GO to Step 3. No - GO to Step 5.	DC/DC Converter 2 (optional)
3	1. Disconnect the power point harness connector. 2. Connect a DVOM between the power point harness connector terminal 1 and terminal 2. Does the DVOM display approximately 12 volts? Yes – INSTALL a new power point. OPERATE the system to verify the repair. No - GO to Step 4.	DC/DC Converter 2 (optional)
4	Connect a DVOM between the DC/DC converter 2 (optional) harness connector terminal 1 and the power point harness connector terminal 2.	DC/DC Converter 2 (optional) Power Point

Step	Action	Connector End View
	<p>Does continuity exist?</p> <p>Yes – REPAIR circuit 65. OPERATE the system to verify the repair.</p> <p>No - REPAIR circuit 57. OPERATE the system to verify the repair.</p>	
5	<ol style="list-style-type: none"> 1. Place the service disconnect switch in the OFF position. 2. Disconnect the DC/DC converter 2 (optional) harness connector. 3. Connect a DVOM between the DC/DC converter 2 (optional) harness connector terminal 3 and terminal 4. 4. Place the service disconnect switch in the ON position. <p>Does the DVOM display approximately 72 volts?</p> <p>Yes – INSTALL a new DC/DC converter 2 (optional). REFER to DC/DC Converter 2 (Optional) in this section. OPERATE the system to verify the repair.</p> <p>No – GO to Step 6.</p>	DC/DC Converter 2 (optional)
6	<p>Check continuity between the DC/DC converter 2 (optional) harness connector terminal 3 and the battery pack negative.</p> <p>Does continuity exist?</p> <p>Yes - REPAIR circuit 43. OPERATE the system to verify the repair.</p> <p>No – REPAIR circuit 4. OPERATE the system to verify the repair.</p>	DC/DC Converter 2 (optional)

Wiper/Washer

Circuit Description and Operation

This is a conventional single speed wiper system. When the drive mode selector switch is in the Reverse, Turf or Drive position, 12 volt power is supplied from the DC/DC converter 1 (standard) through the DC/DC relay to the wiper/washer fuse. The 12 volt return for the wiper motor is provided through DC/DC converter 1 (standard). When the wiper switch is turned ON, 12 volt power is supplied through the multifunction switch to the wiper motor. When the wiper switch is turned OFF, the wiper motor returns the wiper to the park position. When the washer switch is held in the ON position, the washer pump operates. The wiper switch must be in the ON position for the washer to operate.

Circuit Schematic

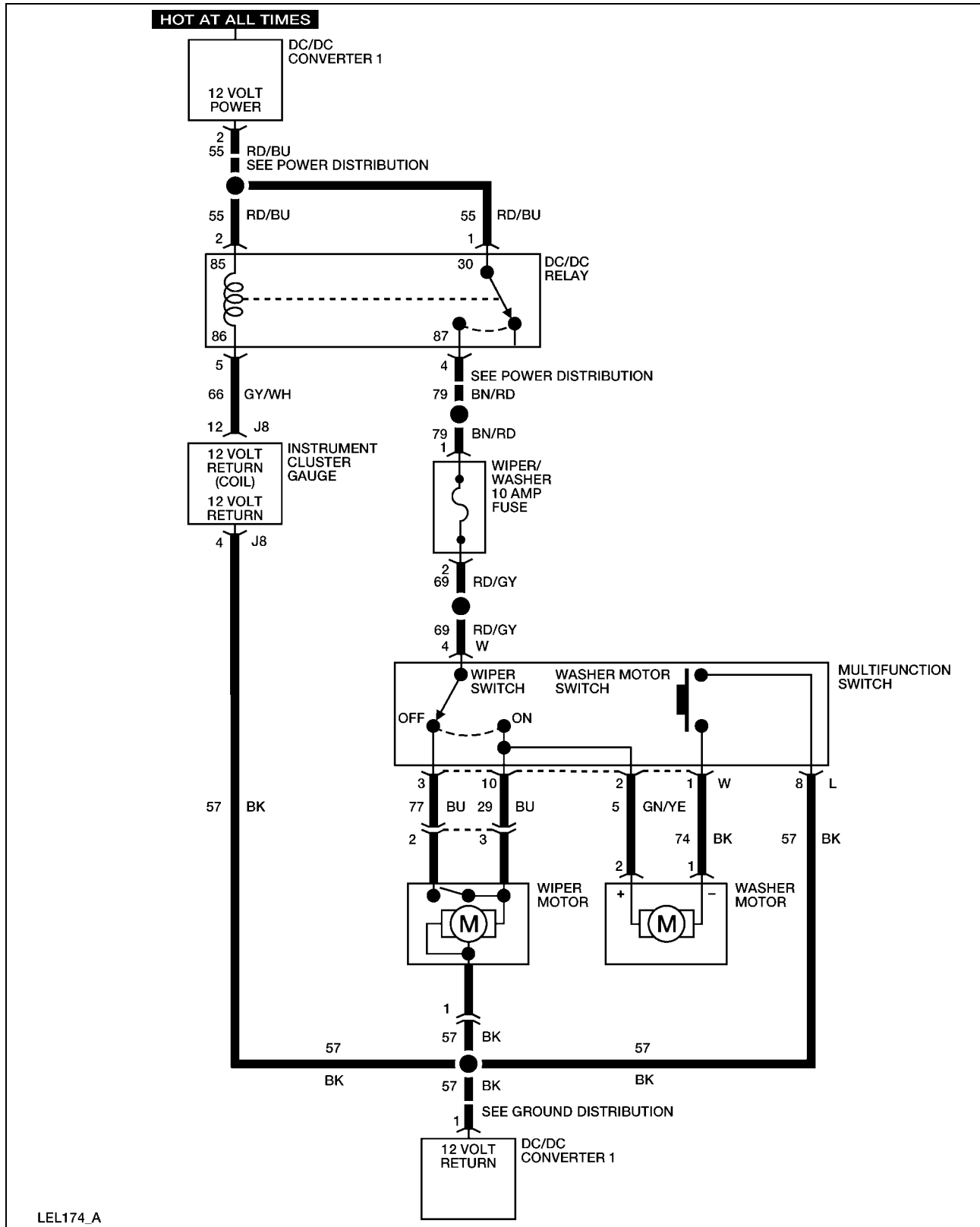

LEL174_A

System Check

Functional components in the wiper/washer system are:

- Wiper/washer fuse
- Multifunction switch
- Instrument cluster gauge
- Washer motor
- Wiper motor
- Related wiring

Guidelines to diagnose the wiper/washer system:

1. Verify the concern.
2. Check the fuse(s).
3. Check all connectors and related wiring for partially seated terminals, connectors not mating properly and for dirt, moisture or corrosion. For proper contact, terminal(s) must be free of all foreign material.
4. Fill washer fluid as necessary.
5. Check washer hoses/nozzles for obstruction.

If the concern still exists, refer to the following table:

Symptom Chart

Symptom	Possible Causes	Action
The washer is inoperative	<ul style="list-style-type: none"> • Wiper/washer fuse • Washer motor • Multifunction switch • Connectors or related wiring 	GO to Washer Inoperative.
The wiper is inoperative	<ul style="list-style-type: none"> • Wiper/washer fuse • Wiper motor • Connectors or related wiring 	GO to Wiper Inoperative.
The wiper is always on	<ul style="list-style-type: none"> • Multifunction switch • Wiper motor • Connectors or related wiring 	GO to Wiper Always On.
The wiper does not stop in the park position	<ul style="list-style-type: none"> • Wiper motor 	INSTALL a new wiper motor. REFER to Wiper Motor in this section. OPERATE the system to verify the repair.

Washer Inoperative

Step	Action	Connector End View
1	<p>Did you read the Circuit Description and Operation?</p> <p>Yes – GO to Step 2.</p> <p>No – REFER to Circuit Description and Operation.</p>	
2	<ol style="list-style-type: none"> 1. Disconnect the washer motor harness connector. 2. Set the park brake. 3. Place the drive mode selector switch in the Reverse, Turf or Drive position. 4. Connect a DVOM between the washer motor harness connector terminal 1 and terminal 2. 5. Place the wiper switch in the ON position. 6. Press the washer motor switch. <p>Does the DVOM display approximately 12 volts?</p> <p>Yes – INSTALL a new washer motor. OPERATE the system to verify the repair.</p> <p>No – GO to Step 3.</p>	Washer Motor
3	<ol style="list-style-type: none"> 1. Disconnect the multifunction switch harness connector W. 2. Connect a DVOM between the multifunction switch harness connector W terminal 4 and the vehicle chassis. <p>Does the DVOM display approximately 12 volts?</p> <p>Yes – GO to Step 4.</p> <p>No – REPAIR circuit 69. OPERATE the system to verify the repair.</p>	Multifunction Switch-W
4	<ol style="list-style-type: none"> 1. Check continuity between the washer motor harness connector terminal 1 and the multifunction switch harness connector W terminal 1. 2. Check continuity between the washer motor harness connector terminal 2 and the multifunction switch harness connector W terminal 2. <p>Does continuity exist?</p> <p>Yes – INSTALL a new multifunction switch. REFER to Multifunction Switch in this section. OPERATE the</p>	Washer Motor Multifunction Switch-W

Step	Action	Connector End View
	<p>system to verify the repair.</p> <p>No – REPAIR circuit 5 or circuit 74. OPERATE the system to verify the repair.</p>	

Wiper Inoperative

Step	Action	Connector End View
1	<p>Did you read the Circuit Description and Operation?</p> <p>Yes – GO to Step 2.</p> <p>No – REFER to Circuit Description and Operation.</p>	
2	<ol style="list-style-type: none"> 1. Disconnect the wiper motor harness connector. 2. Set the park brake. 3. Place the drive mode selector switch in the Reverse, Turf or Drive position. 4. Connect a DVOM between the wiper motor harness connector terminal 3 and the vehicle chassis. 5. Place the wiper switch in the ON position. <p>Does the DVOM display approximately 12 volts?</p> <p>Yes – GO to Step 3.</p> <p>No – GO to Step 4.</p>	Wiper Motor
3	<p>Check continuity between the wiper motor harness connector terminal 1 and the vehicle chassis.</p> <p>Does continuity exist?</p> <p>Yes – INSTALL a new wiper motor. REFER to Wiper Motor in this section. OPERATE the system to verify the repair.</p> <p>No – REPAIR circuit 57. OPERATE the system to verify the repair.</p>	Wiper Motor
4	<ol style="list-style-type: none"> 1. Disconnect the multifunction switch harness connector W. 2. Connect a DVOM between the multifunction switch harness connector W terminal 4 and the vehicle chassis. <p>Does the DVOM display approximately 12 volts?</p> <p>Yes – GO to Step 5.</p>	Multifunction Switch-W

Step	Action	Connector End View
	No – GO to Step 6.	
5	<p>Check continuity between the multifunction switch harness connector W terminal 10 and the wiper motor harness connector terminal 3.</p> <p>Does continuity exist?</p> <p>Yes – INSTALL a new wiper motor. REFER to Wiper Motor in this section. OPERATE the system to verify the repair.</p> <p>No – REPAIR circuit 29. OPERATE the system to verify the repair.</p>	Multifunction Switch-W Wiper Motor
6	<ol style="list-style-type: none"> 1. Remove the wiper/washer fuse from the fuse holder. 2. Connect a DVOM between the multifunction switch harness connector W terminal 4 and the wiper/washer fuse holder terminal 2. <p>Does continuity exist?</p> <p>Yes – REFER to DC/DC Relay Test.</p> <p>No – REPAIR circuit 69. OPERATE the system to verify the repair.</p>	Multifunction Switch-W

Wiper Always On

Step	Action	Connector End View
1	<p>Did you read the Circuit Description and Operation?</p> <p>Yes – GO to Step 2.</p> <p>No – REFER to Circuit Description and Operation.</p>	
2	<ol style="list-style-type: none"> 1. Disconnect the multifunction switch harness connector W. 2. Check operation of the wiper motor. <p>Does the wiper motor continue to operate?</p> <p>Yes – REPAIR circuit 29 between the multifunction switch and the wiper motor. OPERATE the system to verify the repair.</p> <p>No – GO to Step 3.</p>	
3	<p>Check continuity between the multifunction switch harness connector W terminal 4 and the multifunction switch harness</p>	Multifunction Switch-W

Step	Action	Connector End View
	<p>connector W terminal 10 with the wiper switch in the OFF position.</p> <p>Does continuity exist?</p> <p>Yes – INSTALL a new multifunction switch. REFER to Multifunction Switch in this section. OPERATE the system to verify the repair.</p> <p>No – INSTALL a new wiper motor. REFER to Wiper Motor in this section. OPERATE the system to verify the repair.</p>	

Connector End Views

- Accelerator Potentiometer
- Brake Fluid Level Switch
- Charger
- Contactor Coil
- DC/DC Converter 2 (Optional)
- Electronic Flasher
- Fuse, Lights
- Fuse, Wiper/Washer
- Headlamp RH
- Heater/Defogger (Fan)
- Heater/Defogger Inline
- Horn Relay
- Instrument Cluster Gauge – J8
- Motor Controller
- Multifunction Switch – L
- Power Point
- Taillamp RH
- Turn Signal LR
- Turn Signal RR
- Wiper Motor
- Battery Temperature Sensor
- Brake Switch
- CHMSL/Reverse Lamp
- DC/DC Converter 1 (Standard)
- DC/DC Relay
- Fuse, Horn/Flasher/Brake
- Fuse, Power Point
- Headlamp LH
- Heater/Defogger Contactor
- Heater/Defogger (Heater)
- Heater/Defogger Switch
- Instrument Cluster Gauge – J7A
- Key Switch
- Motor Tachometer/Speed Sensor
- Multifunction Switch – W
- Taillamp LH
- Turn Signal LF
- Turn Signal RF
- Washer Motor
- 72 Volt Inline

Accelerator Potentiometer

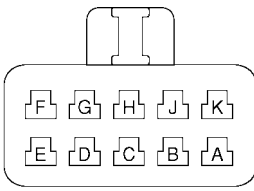
 <p>LEL156_A</p>			
Pin	Wire Color	Circuit	Function
A	VT/GN	34	Wiper 1
B	-	-	-
C	VT/BU	33	12 Volt Power (Switch Output)
D	WH/RD	30	12 Volt Power (Switch Input)
E	VT/BK	35	5 Volt Return
F	-	-	-
G	VT/RD	36	5 Volt Power
H	-	-	-
J	OG/PK	71	Wiper 2
K	-	-	-

Battery Temperature Sensor

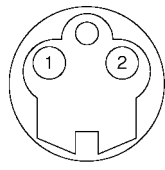
 <p>LEL162_A</p>			
Pin	Wire Color	Circuit	Function
1	GY/BU	16	Battery Temperature Sensor Power
2	GY/GN	17	Battery Temperature Sensor Signal Return

Brake Fluid Level Switch

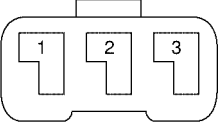
 <p>LEL170_A</p>			
Pin	Wire Color	Circuit	Function
1	BU/GY	7	Brake Fluid Level Switch Power
2	-	-	-
3	YE/GY	8	Brake Fluid Level Switch Signal Return

Brake Switch

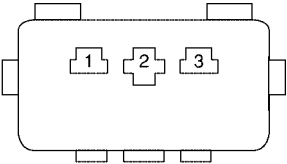
 <p>LEL166_A</p>			
Pin	Wire Color	Circuit	Function
1	RD/ GN	6	12 Volt Power
2	-	-	-
3	BU/BK	22	Brake Switch Signal Return

Charger

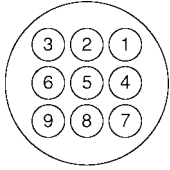
 <p>LEL167_A</p>			
Pin	Wire Color	Circuit	Function
1	OG/GY	11	72 Volt Power
2	OG/BK	4	72 Volt Return
3	GN/BK	67	Charger Inhibit
4	GY/BU	16	Battery Temperature Sensor Power
5	GY/GN	17	Battery Temperature Sensor Signal Return
6	BU/OG	51	Battery Type Select
7	-	-	-
8	-	-	-
9	-	-	-

CHMSL/Reverse Lamp

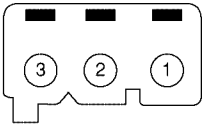
 <p>LEL164_A</p>			
Pin	Wire Color	Circuit	Function
1	BU/RD	68	Reverse Lamp Power
2	BU/BK	22	Brake Lamp Power
3	BK	57	CHMSL/Reverse Lamp Return

Contactor

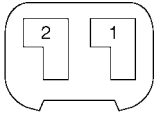
 <p>LEL163_A</p>			
Pin	Wire Color	Circuit	Function
1	BK/GN	39	Contactor Return (Coil)
2	OG/VT	41	Contactor Power (Coil)

DC/DC Converter 1 (Standard)

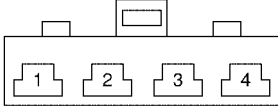
 <p>LEL153_A</p>			
Pin	Wire Color	Circuit	Function
1	BK	57	12 Volt Return
2	RD/BU	55	12 Volt Power
3	OG/BK	4	72 Volt Return
4	OG/YE	43	72 Volt Power

DC/DC Converter 2 (Optional)

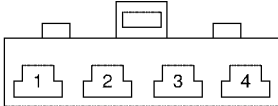
 <p>LEL153_A</p>			
Pin	Wire Color	Circuit	Function
1	BK	57	12 Volt Return
2	RD/BU	55	12 Volt Power
3	OG/BK	4	72 Volt Return
4	OG/YE	43	72 Volt Power

DC/DC Relay

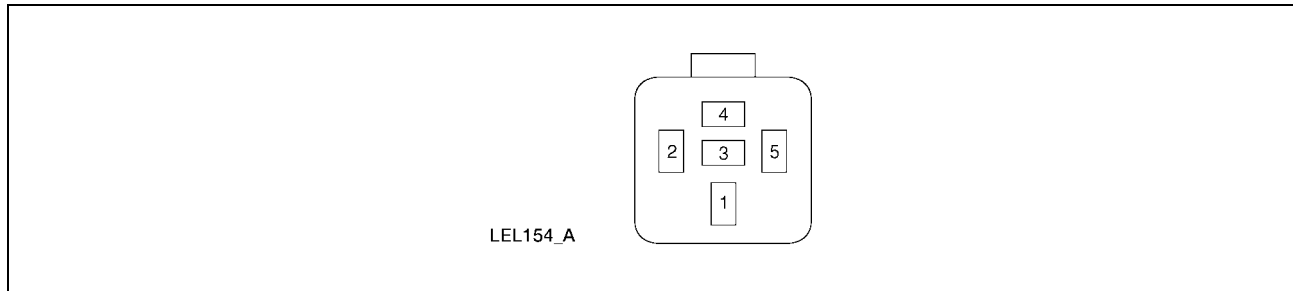

Pin	Wire Color	Circuit	Function
1	RD/BU	55	12 Volt Power (Switch)
2	RD/BU	55	12 Volt Power (Coil)
3	-	-	-
4	BN/RD	79	12 Volt Power (Switched)
5	GY/WH	66	12 Volt Return (Coil)

Drive Mode Selector Switch – J5

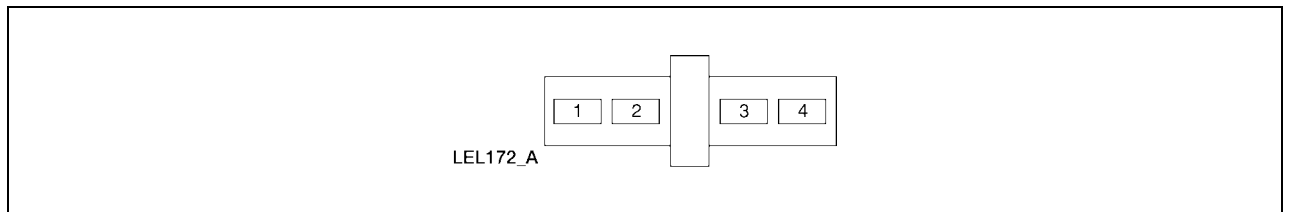

Pin	Wire Color	Circuit	Function
1	-	-	12 Volt Power
2	-	-	Reverse
3	-	-	Turf
4	-	-	Drive

Electronic Flasher

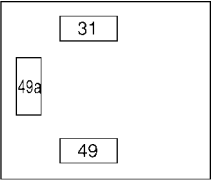
 <p style="margin: 0;">LEL189_A</p>			
Pin	Wire Color	Circuit	Function
31	-	-	Return
49	-	-	Power
49a	-	-	Flash Output

Fuse, ACC

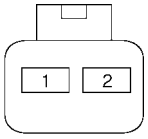
 <p style="margin: 0;">LEL152_A</p>			
Pin	Wire Color	Circuit	Function
1	RD/BU	55	12 Volt Power
2	RD/GN	80	12 Volt Power (Protected)

Fuse, Horn/Flasher/Brake

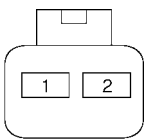
 <p style="margin: 0;">LEL152_A</p>			
Pin	Wire Color	Circuit	Function
1	RD/BU	55	12 Volt Power
2	RD/GN	6	12 Volt Power (Protected)

Fuse, Lights

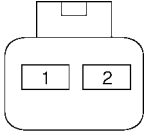
 <p>LEL152_A</p>			
Pin	Wire Color	Circuit	Function
1	BN/RD	79	12 Volt Power
2	RD/GY	69	12 Volt Power (Protected)

Fuse, Power Point

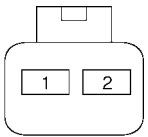
 <p>LEL152_A</p>			
Pin	Wire Color	Circuit	Function
1	RD/WH	65	12 Volt Power (Protected)
2	RD/WH	65	12 Volt Power

Fuse, Wiper/Washer

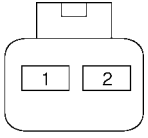
 <p>LEL152_A</p>			
Pin	Wire Color	Circuit	Function
1	BN/RD	79	12 Volt Power
2	RD/GY	69	12 Volt Power (Protected)

Headlamp LH

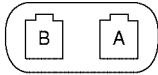
 LEL158_A			
Pin	Wire Color	Circuit	Function
A	BK	57	12 Volt Return
B	RD/BK	13	12 Volt Power (Switched)

Headlamp RH

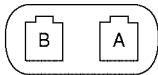
 LEL158_A			
Pin	Wire Color	Circuit	Function
A	BK	57	12 Volt Return
B	RD/BK	13	12 Volt Power (Switched)

Heater/Defogger Contactor

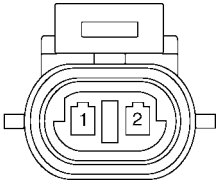
 LEL233_A			
Pin	Wire Color	Circuit	Function
1	RD	81	12 Volt Power
2	BK	57	12 Volt Return

Heater/Defogger (Fan)

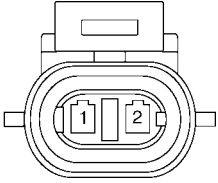
 <p>LEL235_A</p>			
Pin	Wire Color	Circuit	Function
1	RD	81	12 Volt Power
2	BK	57	12 Volt Return

Heater/Defogger (Heater)

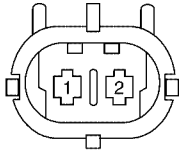
 <p>LEL236_A</p>			
Pin	Wire Color	Circuit	Function
1	OR/BK	4	72 Volt Return
2	OG/YE	43	72 Volt Power

Heater/Defogger Inline

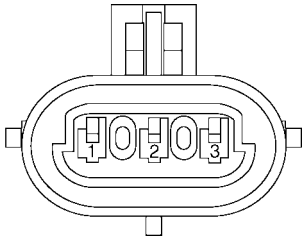
 <p>LEL237_A</p>			
Pin	Wire Color	Circuit	Function
1	RD/GY	69	12 Volt Power (Except Key Off)
2	RD/GN	80	12 Volt Power
3	BK	57	12 Volt Return

Heater/Defogger Switch

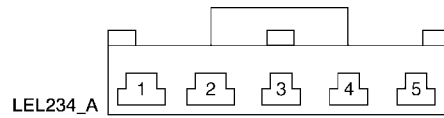

Pin	Wire Color	Circuit	Function
1	RD	81	12 Volt Power (Heater/Defogger ON)
2	RD/GN	80	12 Volt Power
3	RD/GY	69	12 volt Power (Switched)
4	BK	57	12 Volt Return
5	-	-	-

Horn Relay

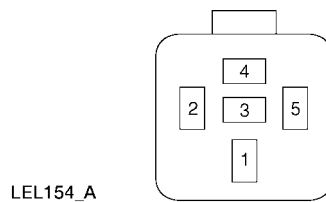

Pin	Wire Color	Circuit	Function
1	BK	57	12 Volt Return (Switch)
2	GN/BU	28	12 Volt Power (Horn Switch Closed) (Coil)
3	-	-	-
4	BN/RD	78	Horn Control
5	BK	57	12 Volt Return (Coil)

Instrument Cluster Gauge – J7A

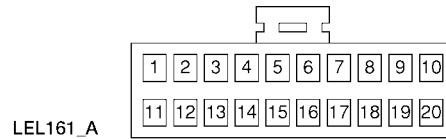

Pin	Wire Color	Circuit	Function
1	OG/VT	41	72 Volt Power
2	WH/BN	44	Key On Signal
3	WH/OG	45	Drive Signal
4	WH/YE	46	Reverse Signal
5	WH/VT	47	Turf Signal
6	BK/BU	50	Back Up Alarm
7	OG/VT	41	Contactor Power (Coil)
8	-	-	-
9	WH/GN	31	Tachometer Signal
10	WH/RD	30	12 Volt Power (Output) (Except Key Off)
11	WH	48	Serial Communication
12	VT	49	Serial Communication
13	GN/BK	67	Charger Inhibit
14	OG/BK	4	72 Volt Return
15	OG/GN	10	Leakage Detection
16	-	-	-
17	-	-	-
18	BU/OG	51	Battery Type Select
19	-	-	-
20	-	-	-

Instrument Cluster Gauge – J8

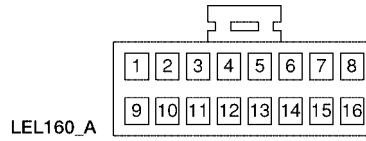

Pin	Wire Color	Circuit	Function
1	BK/VT	37	Park Brake Switch Power
2	BK/YE	38	Park Brake Switch Signal Return
3	RD/GY	69	12 Volt Power (Except Key Off)
4	BK	57	12 Volt Return
5	GN/WH	3	Turn Indicator LH
6	WH/BU	2	Turn Indicator RH
7	BU/RD	68	Reverse Lamp Power
8	BU/GY	7	Brake Fluid Level Switch Power
9	YE/GY	8	Brake Fluid Level Switch Signal Return
10	-	-	-
11	-	-	-
12	GY/WH	66	12 Volt Return (Coil)
13	RD/GN	6	12 Volt Power
14	-	-	-
15	-	-	-
16	-	-	-

Motor Controller

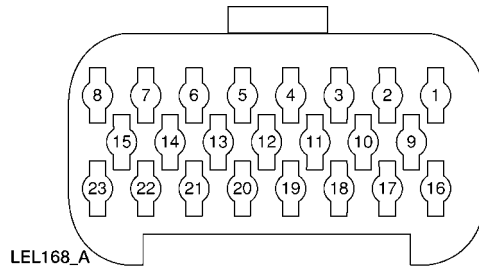

Pin	Wire Color	Circuit	Function
1	OG/VT	41	72 Volt Power
2	WH/BN	44	Key On Signal
3	VT/BU	33	12 Volt Power (Switched)
4	WH/VT	47	Turf Signal
5	WH/YE	46	Reverse Signal
6	WH/OG	45	Drive Signal
7	VT/GN	34	Accelerator Potentiometer Wiper 1
8	VT/BK	35	5 Volt Return
9	VT/RD	36	5 Volt Power
10	BK/BU	50	Back Up Alarm
11	BK/GN	39	Contactora Coil Control
12	-	-	-
13	OG/PK	71	Accelerator Potentiometer Wiper 2
14	WH/GN	31	Tachometer Pulse
15	-	-	-
16	WH/BK	32	Tachometer Return
17	-	-	-
18	-	-	-
19	-	-	-
20	-	-	-
21	OG/WH	73	Motor Thermostat
22	WH	48	Serial Communication
23	VT	49	Serial Communication

Motor Tachometer/Speed Sensor

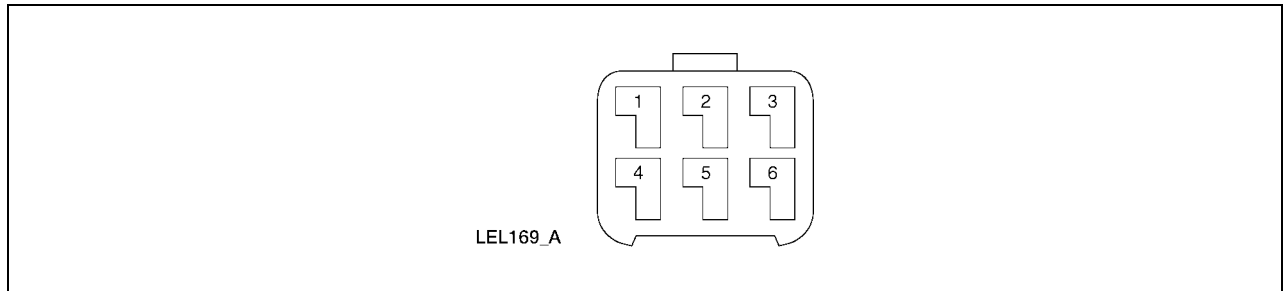

Pin	Wire Color	Circuit	Function
1	OG/WH	73	Motor Thermostat
2	-	-	-
3	WH/RD	30	12 Volt Power
4	WH/RD	30	12 Volt Power
5	WH/BK	32	12 Volt Return
6	WH/GN	31	Pulse

Multifunction Switch - L

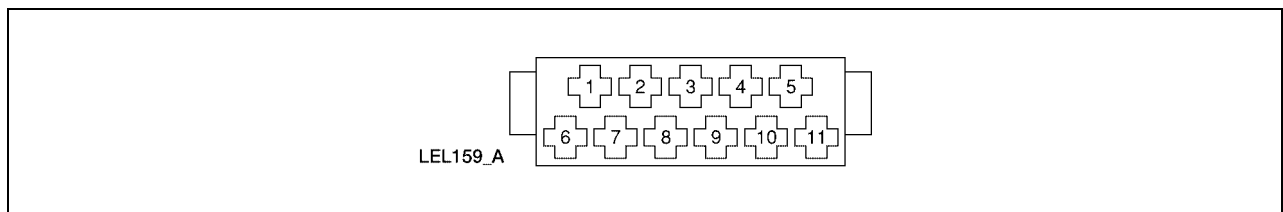

Pin	Wire Color	Circuit	Function
1	RD/BK	13	Flash-To-Pass
2	-	-	-
3	RD/BK	13	12 Volt Power (Output)
4	RD/GY	69	12 Volt Power (Switched)
5	GN/WH	3	Left Turn Signal (Output)
6	RD/GY	69	12 Volt Power (Switched)
7	RD/BN	14	12 Volt Power (Output)
8	BK	57	12 Volt Return
9	RD/GY	69	12 Volt Power (Switched)
10	RD/GN	6	12 Volt Power
11	WH/BU	2	Right Turn Signal (Output)

Multifunction Switch - W

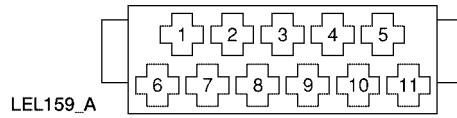

Pin	Wire Color	Circuit	Function
1	BK	74	Washer Motor Return
2	GN/YE	5	Washer Motor Signal (Output)
3	BU	77	Wiper Motor Return
4	RD/GY	69	12 Volt Power (Switched)
5	-	-	-
6	-	-	-
7	-	-	-
8	-	-	-
9	-	-	-
10	GN	29	Wiper Motor Signal (Output)
11	GN/BU	28	12 Volt Power (Horn Switch Closed)

Power Point

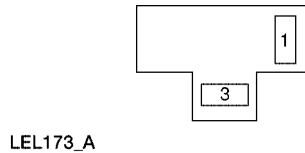

Pin	Wire Color	Circuit	Function
1	RD/WH	65	12 Volt Power
2	BK	57	12 Volt Return

Taillamp LH

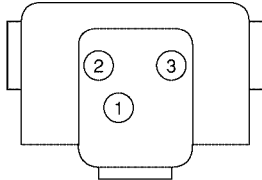
 <p>LEL165_A</p>			
Pin	Wire Color	Circuit	Function
1	RD	22	12 Volt Power (Switched)
2	BK	14	12 Volt Power (Switched)
3	WH	57	12 Volt Return

Taillamp RH

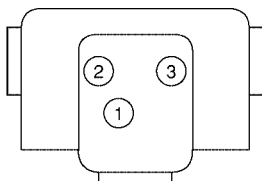
 <p>LEL165_A</p>			
Pin	Wire Color	Circuit	Function
1	RD	22	12 Volt Power (Switched)
2	BK	14	12 Volt Power (Switched)
3	WH	57	12 Volt Return

Turn Signal LF

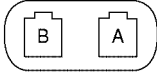
 <p>LEL158_A</p>			
Pin	Wire Color	Circuit	Function
A	BK	57	12 Volt Return
B	GN/WH	3	12 Volt Power (Pulsed)

Turn Signal LR

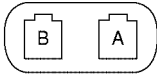
			
Pin	Wire Color	Circuit	Function
A	BK	57	12 Volt Return
B	GN/WH	3	12 Volt Power (Pulsed)

Turn Signal RF

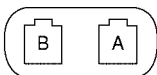
			
Pin	Wire Color	Circuit	Function
A	BK	57	12 Volt Power Return
B	WH/BU	2	12 Volt Power (Pulsed)

Turn Signal RR

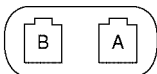
			
Pin	Wire Color	Circuit	Function
A	BK	57	12 Volt Return
B	WH/BU	2	12 Volt Power (Pulsed)

Washer Motor

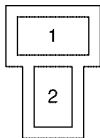
			
Pin	Wire Color	Circuit	Function
1	GN/YE	5	Washer Motor Power
2	BK	74	Washer Motor Return

Wiper Motor

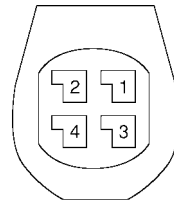

LEL157_A

Pin	Wire Color	Circuit	Function
1	BK	57	Wiper Motor Return
2	BU	77	Wiper Motor Signal Return
3	GN	29	Wiper Motor Power
4	-	-	-

72 Volt Inline

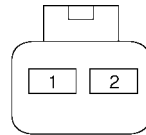

LEL152_A

Pin	Wire Color	Circuit	Function
1	OG/YE	43	72 Volt Power
2	OG/BK	4	72 Volt Return

Removal and Installation



Accelerator/Potentiometer

Removal and Installation

Refer to [Accelerator/Potentiometer](#) in the Powertrain section.

Batteries

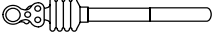
Required Tools

High Voltage Insulated Gloves, 100-F036 or Equivalent		Battery Post Torque Wrench, 307-026 or Equivalent	
Battery Terminal Cap Opener, 418-F215		Face Shield, 100-F035 or Equivalent	

Removal

LEAD-ACID BATTERIES CONTAIN SULFURIC ACID. AVOID CONTACT WITH SKIN, EYES OR CLOTHING. ALSO, SHIELD YOUR EYES WHEN WORKING NEAR BATTERIES TO PROTECT AGAINST SPLASHING OF THE ACID SOLUTION. IN CASE OF ACID CONTACT WITH THE SKIN OR EYES, FLUSH IMMEDIATELY WITH WATER FOR A MINIMUM OF FIFTEEN MINUTES AND GET PROMPT MEDICAL ATTENTION. IF ACID IS SWALLOWED, DRINK LARGE QUANTITIES OF MILK OR WATER, FOLLOWED BY MILK OF MAGNESIA, A BEATEN EGG, OR VEGETABLE OIL. CALL A PHYSICIAN IMMEDIATELY.

WARNING!

BATTERIES NORMALLY PRODUCE EXPLOSIVE GASES WHICH CAN CAUSE PERSONAL INJURY OR DEATH. DO NOT ALLOW FLAMES, SPARKS OR LIGHTED SUBSTANCES TO COME NEAR THE BATTERIES. WHEN CHARGING OR WORKING NEAR THE BATTERIES, ALWAYS SHIELD YOUR FACE AND PROTECT YOUR EYES. ALWAYS PROVIDE ADEQUATE VENTILATION.

WARNING!

MAKE SURE THE VEHICLE IS NOT BEING CHARGED.

CAUTION:

If the type of battery (flooded to gel, gel to flooded) is being changed the instrument cluster gauge must be reprogrammed to avoid battery pack damage. The charging rate differs between type of battery and the battery water reminder indicator must be turned on for flooded type batteries. Refer to [Battery Type Reprogramming](#) procedure in this section.

1. Remove the driver and passenger seat. Refer to [Seat Back and Frame – Driver Seat](#) and [Seat Back and Frame – Passenger Seat](#) in the Body section.
2. Remove the seat stanchion cover. Refer to [Seat Stanchion Cover](#) in the Body section
3. Turn the vehicle power off. Refer to [Power Shutdown Procedure](#) in this section.
4. Remove the “H” frame bolts and the “H” frame.
5. Remove the tie strap from the battery cable.
6. Remove the battery hold-down strap nuts (A) and battery hold-down bracket bolts (B).

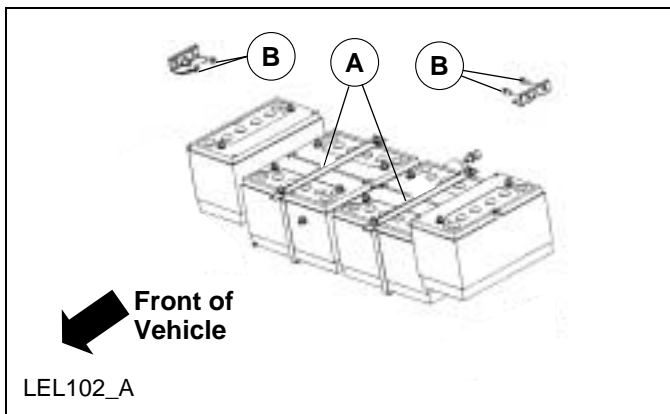

7. Remove the parking brake lever. Refer to [Parking Brake Lever](#) in the Chassis section.
8. Use Battery Terminal Cap Opener to open the battery terminal covers.
9. Disconnect the battery cables. Make note of their locations before removing.

WARNING!

WHEN LIFTING A BATTERY, EXCESSIVE PRESSURE ON THE END WALLS COULD CAUSE ACID TO LEAK OUT THROUGH THE VENT CAPS, RESULTING IN PERSONAL INJURY, DAMAGE TO THE VEHICLE OR BATTERY. LIFT WITH BATTERY CARRIER.

CAUTION:

Do not use a battery carrier that lifts by the battery posts. Internal battery damage could occur.

10. Use a side clamping battery carrier, and carefully remove the batteries.

Installation**WARNING!**

WHEN LIFTING A BATTERY, EXCESSIVE PRESSURE ON THE END WALLS COULD CAUSE ACID TO LEAK OUT THROUGH THE VENT CAPS, RESULTING IN PERSONAL INJURY, DAMAGE TO THE VEHICLE OR BATTERY. LIFT WITH BATTERY CARRIER.

CAUTION:

Do not use a battery carrier that lifts by the battery posts. Internal battery damage could occur.

CAUTION:

When replacing a battery or batteries, all of the batteries in the battery pack including the new battery (batteries) should be fully charged over night to prevent an uneven charge condition that will cause premature failure and could reduce the life of the battery pack.

CAUTION:

Do not mix flooded and gel type batteries. Damage to the battery pack will occur.

Note:

To ensure full battery life and vehicle range if the battery pack has been in service for more than one month the complete battery pack must be replaced.

1. Use a side clamping battery carrier, and carefully install the batteries.

2. Install the battery hold-down straps and brackets. Tighten the battery hold-down strap nuts (A) to 8N.m. (70lb-in.) Tighten the battery hold-down bracket bolts (B) to 24-28N.m. (18-20lb-ft.)

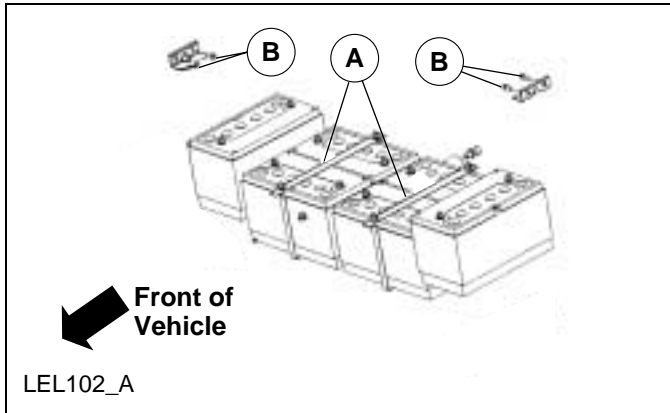

3. Install a new tie strap to hold the battery cable in place.
4. Install the parking brake lever. Refer to [Parking Brake Lever](#) in the Chassis section.
5. Apply Electrical Grease F8AZ-19G208-AA or equivalent meeting Ford specification WSB-M1C239-A to the battery posts.
6. Refer to the mounting notes during removal and connect the battery cables. Use Battery Post Torque Wrench to tighten the battery cable clamp nuts to 12-15N.m. (107-132lb-in.).
7. Install the “H” frame. Tighten the “H” frame bolts to 20-30N.m. (15-22lb-ft.).
8. Remove the seat stanchion cover. Refer to [Seat Stanchion Cover](#) in the Body section
9. Turn the vehicle power on. Refer to [Power Shutdown Procedure](#) in this section.

Charger

Removal

WARNING!

MAKE SURE THE VEHICLE IS NOT BEING CHARGED.

1. Remove the seat stanchion cover. Refer to [Seat Stanchion Cover](#) in the Body section
2. Turn the vehicle power off. Refer to [Power Shutdown Procedure](#) in this section.
3. Unlock and remove the hood.

4. Raise and support the vehicle.
5. Drill out the four rivets and remove the LH fender shield.

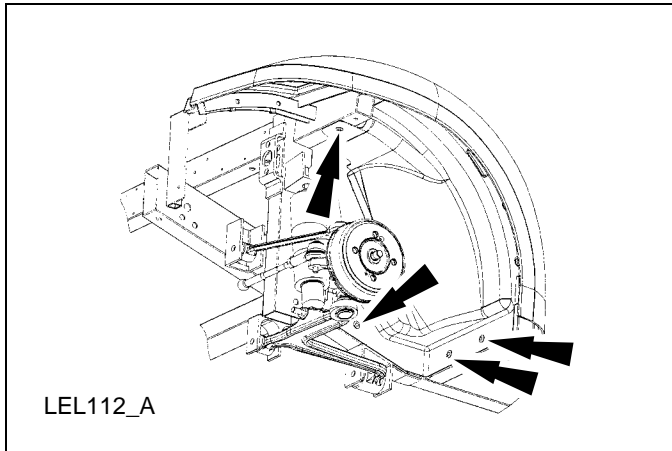

6. Press in the retaining button on the battery charger inlet plug and remove the battery charger inlet plug from the front floor kick-up.

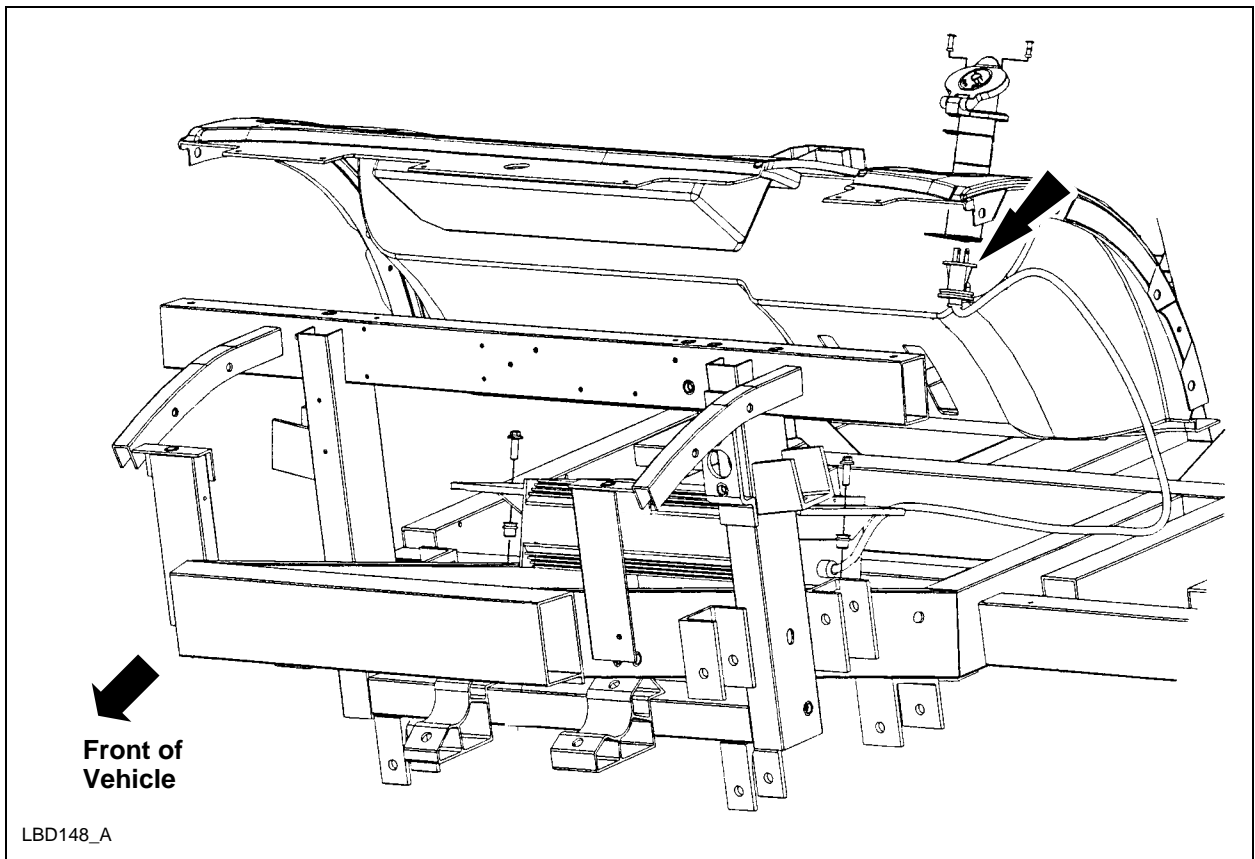

7. Lower the vehicle.

- Disconnect the two electrical connectors and remove the two charger bolts.

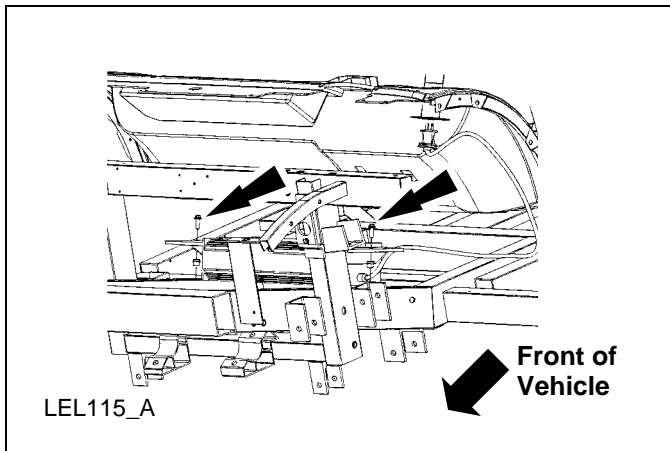

Installation

- Reverse the removal procedure.
- Tighten the two charger bolts to 24-28N.m. (18-20lb-ft.)

Contactor

Removal

WARNING!

MAKE SURE THE VEHICLE IS NOT BEING CHARGED.

- Turn the vehicle power off. Refer to [Power Shutdown Procedure](#) in this section.
- Remove the upper nut (A) attaching the cable to the service disconnect switch and remove the washers (B) and disconnect the cables (C).

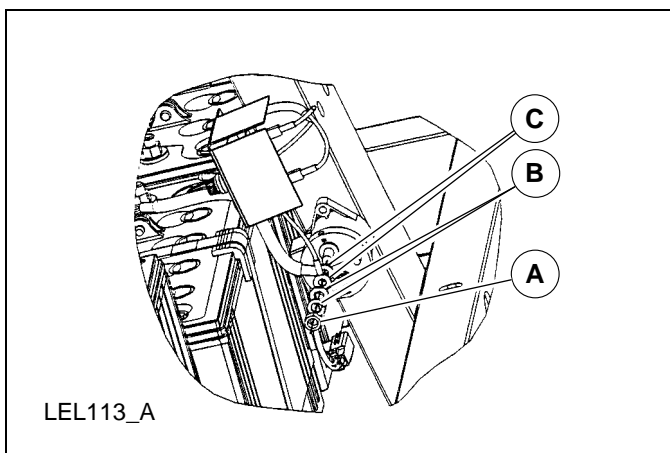

3. Remove the lower nut (A) attaching the cable to the motor controller, remove the washers (B) and disconnect the cable (C).

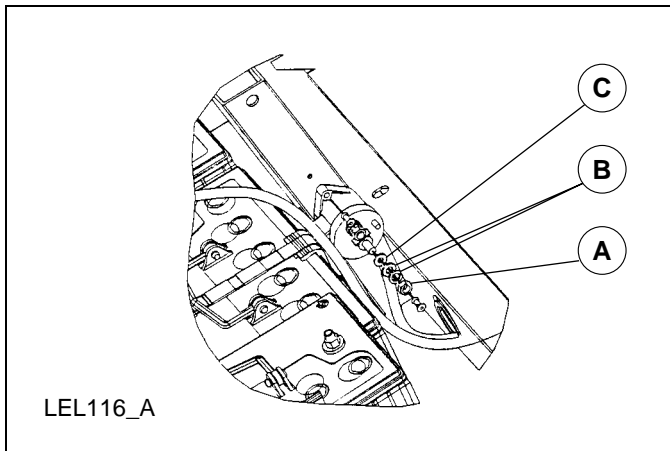

4. Remove the two plastic rivets and the contactor.

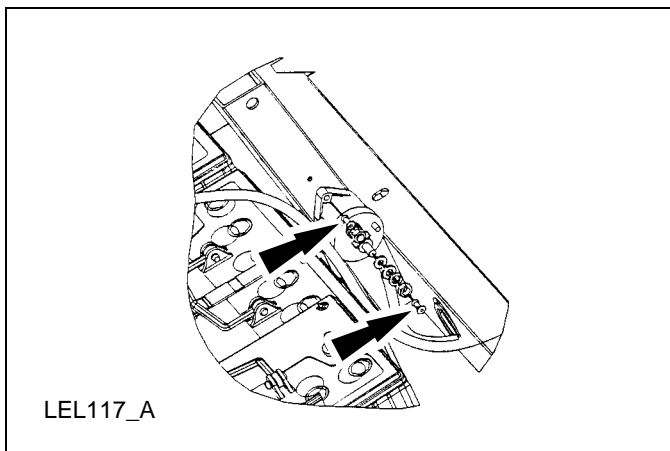

Installation

1. Reverse the removal procedure.
2. Tighten the contactor cable nuts to 8-10N.m. (71-88lb-in.)

Controller, Motor

Removal and Installation

Refer to [Motor Controller](#) in the Powertrain section.

Converter 1, DC/DC -Standard

Removal

WARNING!

MAKE SURE THE VEHICLE IS NOT BEING CHARGED.

1. Remove the seat stanchion cover. Refer to [Seat Stanchion Cover](#) in the Body section.
2. Turn the vehicle power off. Refer to the [Power Shutdown Procedure](#) in this section.
3. Remove the front floor kick-up. Refer to [Front Floor Kick-up](#) in the Body section.
4. Disconnect the DC/DC converter 1 (standard) electrical connector.
5. Drill out the four rivets and remove the DC/DC converter 1 (standard).

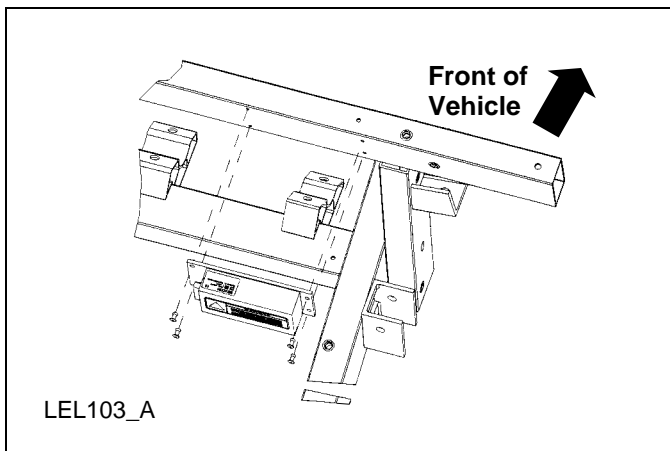

Installation

Reverse the removal procedure.

Converter 2, DC/DC - Optional

Removal

WARNING!

MAKE SURE THE VEHICLE IS NOT BEING CHARGED.

1. Remove the seat stanchion cover. Refer to [Seat Stanchion Cover](#) in the Body section.
2. Turn the vehicle power off. Refer to the [Power Shutdown Procedure](#) in this section.

3. Unlock and remove the hood.
4. Disconnect the DC/DC converter 2 (optional) electrical connector.
5. Drill out the four rivets and remove the DC/DC converter 2 (optional).

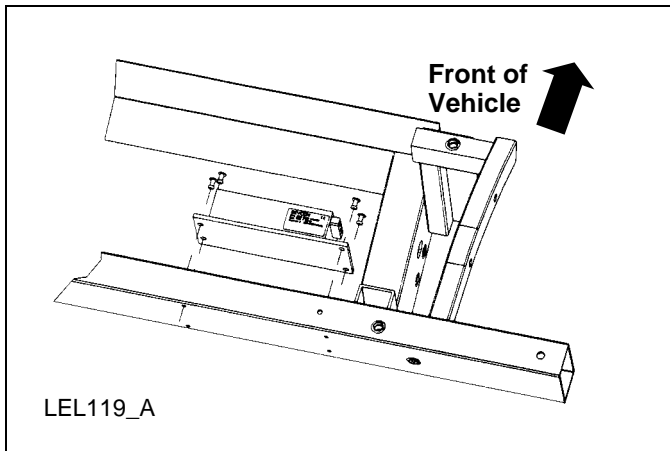

Installation

Reverse the removal procedure.

Instrument Cluster Gauge

Removal

WARNING!

MAKE SURE THE VEHICLE IS NOT BEING CHARGED.

1. If replacing the instrument cluster gauge, turn the drive mode selector switch to D and make a note of the odometer reading. Make sure the odometer is not in TRIP mode.
2. Remove the seat stanchion cover. Refer to [Seat Stanchion Cover](#) in the Body section.
3. Turn the vehicle power off. Refer to the [Power Shutdown Procedure](#) in this section.
4. Remove the RH cowl tray scrivet and the RH cowl tray.

5. Disconnect the four electrical connectors from the instrument cluster gauge.

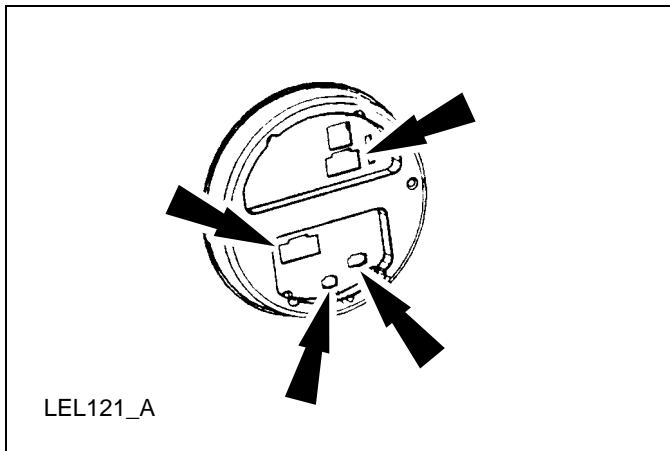

6. While supporting the instrument cluster gauge from behind the instrument panel remove the six instrument cluster gauge screws.

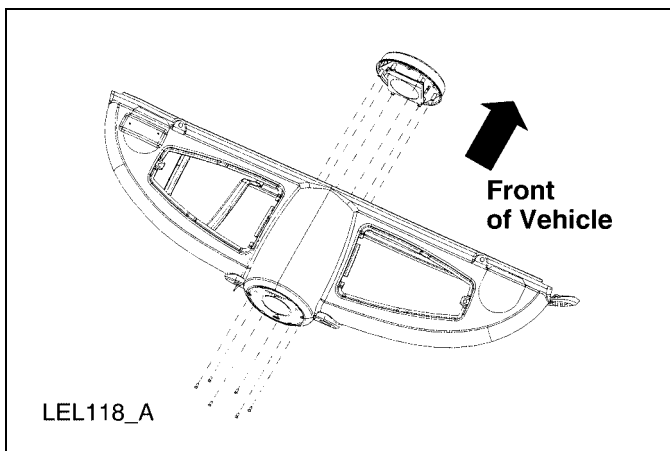

7. Remove the instrument cluster gauge through the cowl tray opening.

Installation

Note:

Federal law requires that the odometer in any replacement speedometer must register the same mileage as that registered in the removed speedometer. Since the mileage cannot be reset on this unit, affix an odometer sticker to the inner area of the A-pillar at the front LH side of the vehicle and record the original mileage.

1. Reverse the removal procedure.
2. Tighten the instrument cluster gauge screws to 0.85-1.15N.m. (7.5-10.1lb-in.)

Headlamp

Removal

WARNING!

MAKE SURE THE VEHICLE IS NOT BEING CHARGED.

1. Remove the front fascia. Refer to [Fascia – Front](#) in the Body section.
2. Disconnect the headlamp electrical connector.

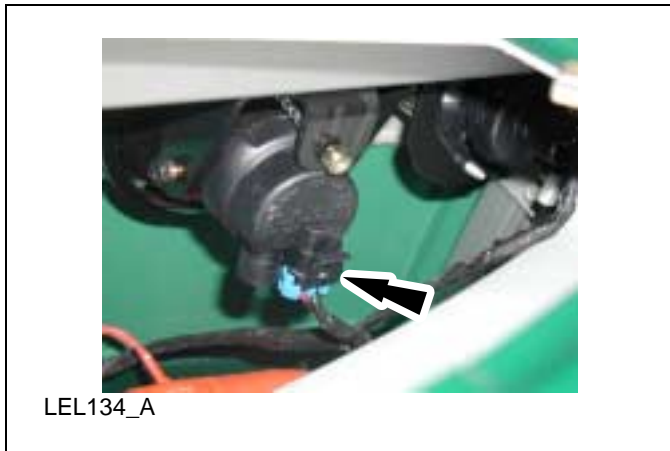

Remove the headlamp bracket bolt and the headlamp assembly.

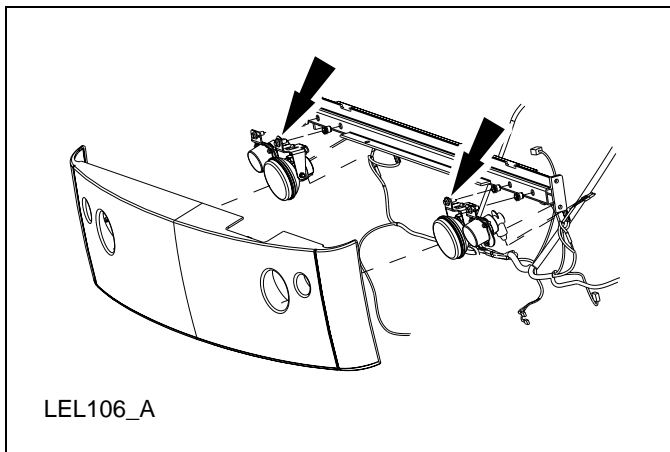

Installation

1. Reverse the removal procedure.
2. Tighten the headlamp bracket bolt to 24-31N.m. (18-22lb-ft.)

Headlamp Bulb

Removal

WARNING!

MAKE SURE THE VEHICLE IS NOT BEING CHARGED.

1. Remove the scrivet and the cowl tray panel.
2. Disconnect the headlamp electrical connector.

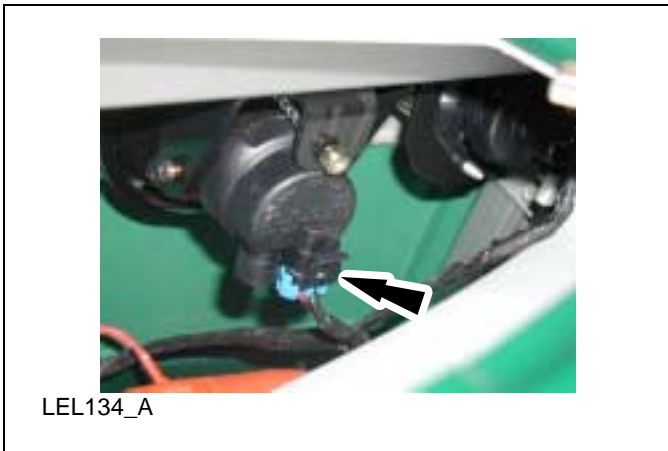

3. Rotate the headlamp bulb shield counterclockwise and flip down to access the bulb connectors.

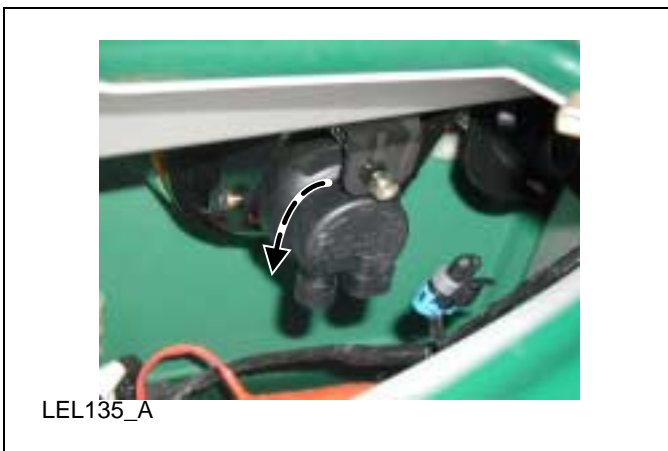

4. Pull the flat connector attached to the white wire from the headlamp bulb shield.

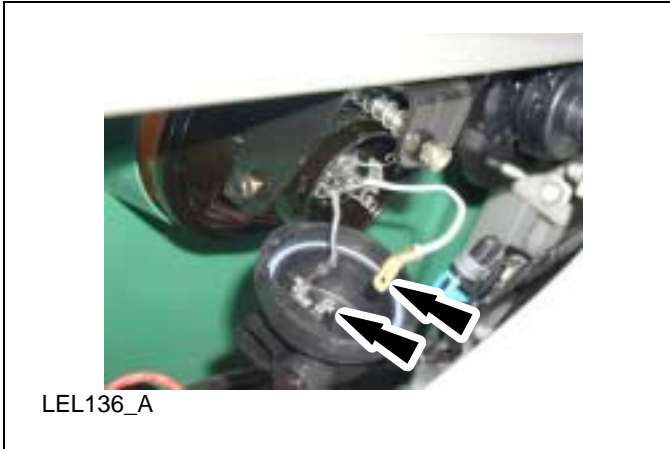

5. Push and squeeze the two bulb retainer wires to disengage them from the headlamp housing. Remove the headlamp bulb.

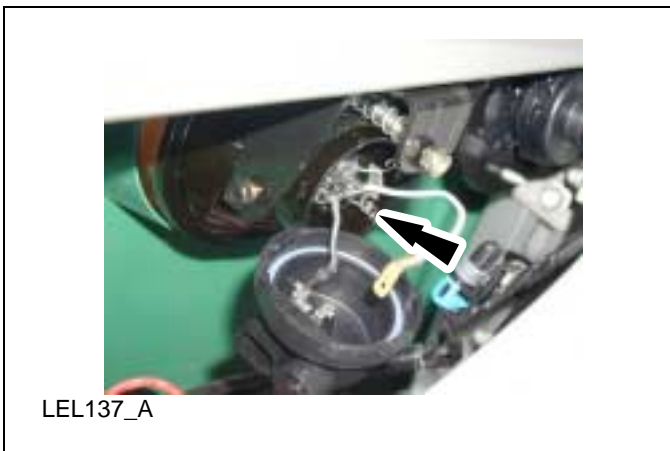

Installation

WARNING!

HANDLE A HALOGEN HEADLAMP BULB CAREFULLY AND KEEP OUT OF CHILDREN'S REACH. GRASP THE BULB ONLY BY ITS METAL BASE AND DO NOT TOUCH THE GLASS. THE OIL FROM YOUR HAND COULD CAUSE THE BULB TO BREAK THE NEXT TIME THE HEADLAMPS ARE OPERATED.

1. Install the headlamp bulb. Squeeze and push the two bulb retainer wires to engage them to the headlamp housing.



2. Push the flat connector attached to the white wire into the headlamp bulb shield.

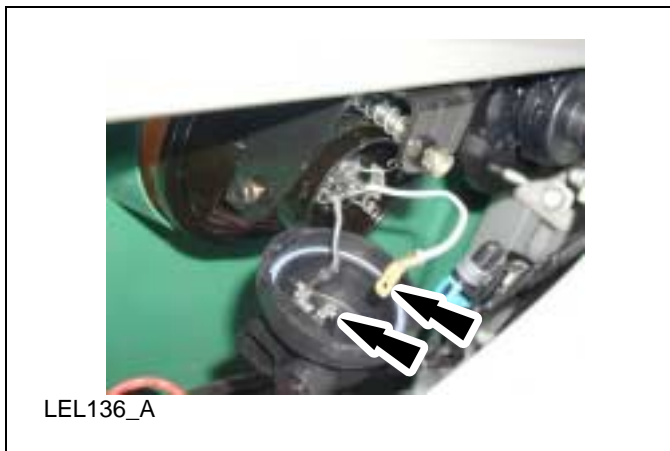

3. Install and rotate the headlamp bulb shield clockwise.

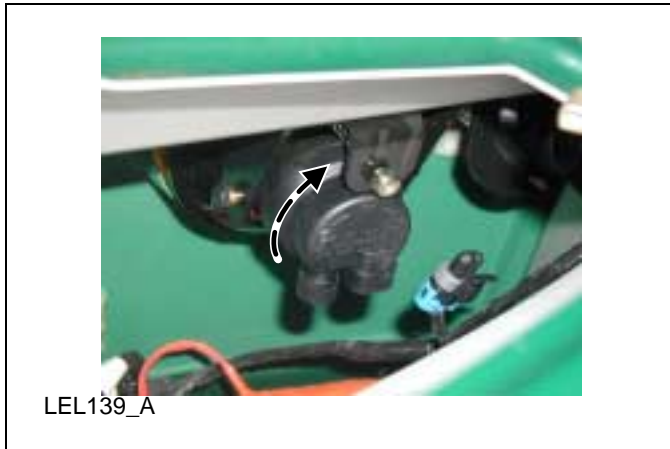

4. Connect the headlamp electrical connector.

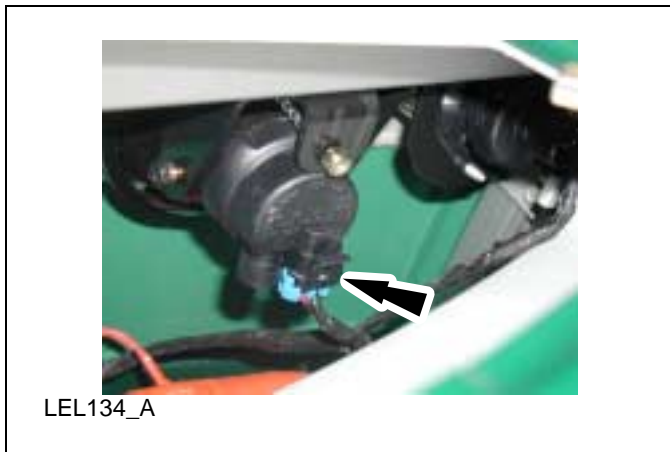

5. Install the cowl tray panel and the scrivet.

Motor

Removal and Installation

Refer to [Motor](#) in the Powertrain section.

Motor, Wiper

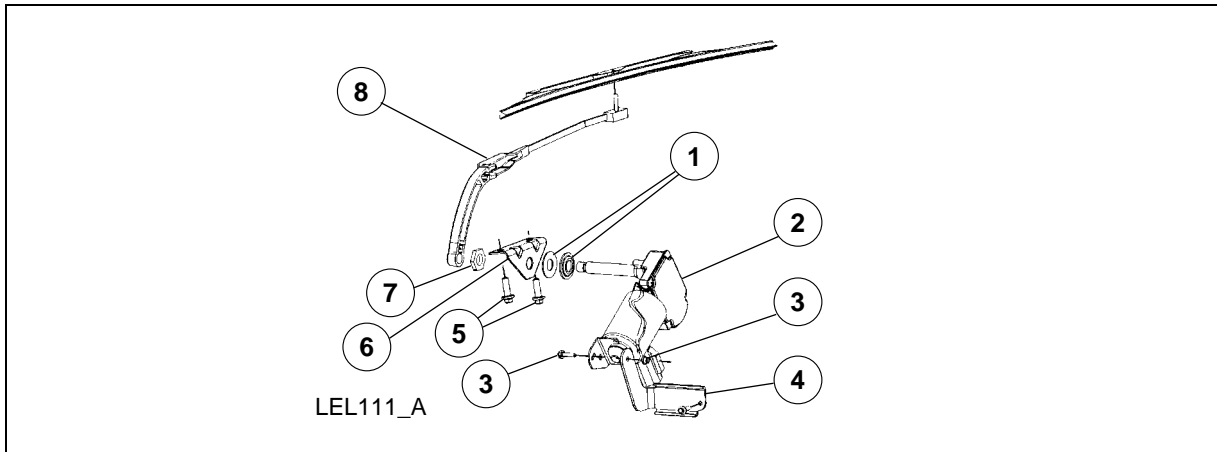

Item	Part Number	Description
1	--	Wiper Motor Shaft Washers
2	17508	Wiper Motor
3	--	Wiper Motor to Lower Bracket Nut and Bolt
4	17496	Wiper Motor Lower Bracket
5	--	Wiper Motor Upper Bracket Bolts
6	17496	Wiper Motor Upper Bracket
7	--	Wiper Motor Shaft Nut
8	17526/17528	Wiper Arm And Blade

Removal

WARNING!

MAKE SURE THE VEHICLE IS NOT BEING CHARGED.

1. Remove the front fascia. Refer to [Fascia – Front](#) in the Body Section.
2. Remove the windshield wiper arm by pressing the release lever and firmly pulling the arm straight off the shaft.
3. Remove the wiper motor shaft nut.

4. Disconnect the wiper motor electrical connector.
5. Remove the wiper motor to lower bracket nut and bolt and remove the wiper motor.

Installation

1. Reverse the removal procedure.
2. Tighten the wiper motor to lower bracket nut to 5-7N.m. (45-61lb.in.).
3. If the wiper motor was replaced adjust the wiper park as follows:
 - a. Turn the vehicle power on but leave the wiper switch OFF.

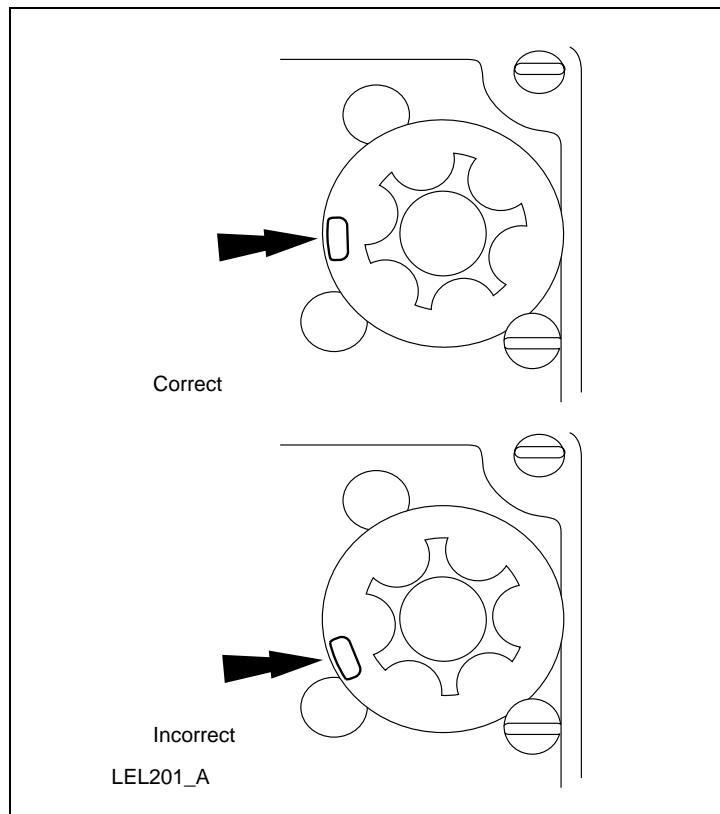

- b. Loosen the setscrew and rotate the disc clockwise until the wiper activates then rotate the disc counterclockwise until the wiper stops working.

Note:

Make sure the windshield is wet prior to cycling the wipers on.

- c. Tighten the setscrew and then cycle and park the wiper on wet glass a few times.
 - d. Repeat as necessary to ensure wiper blade park position is parallel and 4" from the top of the black border on the windshield.

Heater/Defogger System Components

As viewed from the front of the vehicle.

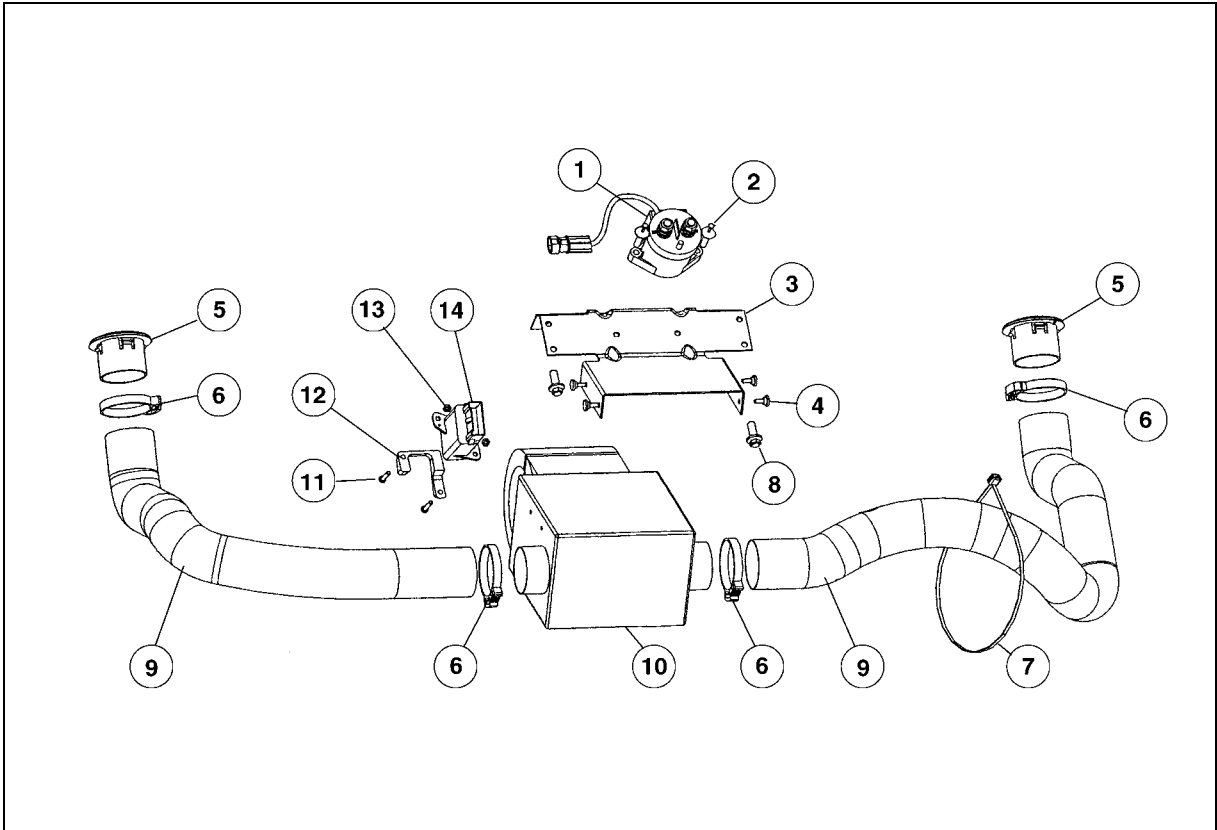

LEL206-A

Item	Part Number	Description
1	--	Heater/defogger contactor
2	--	Rivet
3	--	Heater/defogger bracket
4	--	Heater/defogger screws
5	--	Heater/defogger duct
6	--	Nylon clamps
7	--	Tie strap
8	--	Heater/defogger bracket bolt

Item	Part Number	Description
9	--	Vent hose
10	--	Heater/defogger assembly
11	--	Heater/defogger switch screws
12	--	Heater/defogger switch spacer
13	--	Heater/defogger switch nut
14	--	Heater/defogger switch

Heater/Defogger Assembly

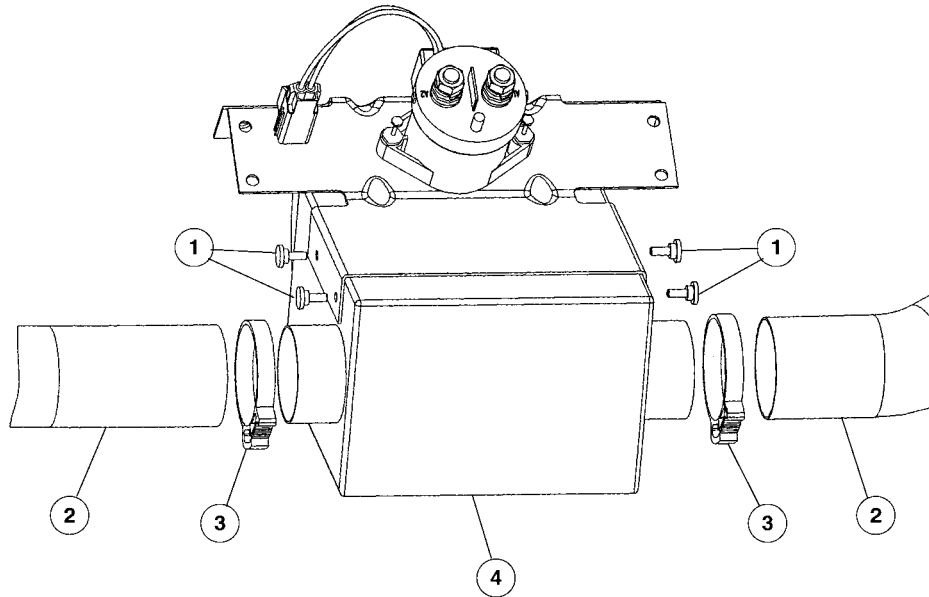

LEL204-A

Item	Part Number	Description
1	--	Heater/defogger screws
2	--	Vent hoses
3	--	Nylon clamps
4	--	Heater/defogger assembly

Removal

1. Remove the front fascia. Refer to [Fascia – Front](#) in the Body section.
2. Loosen the two nylon clamps and slide the vent hoses off of the heater/defogger housing.
3. Disconnect the heater/defogger electrical connector.
4. Support the heater/defogger assembly and remove the four heater/defogger screws.

Installation

Reverse the removal procedure.

Heater/Defogger Switch

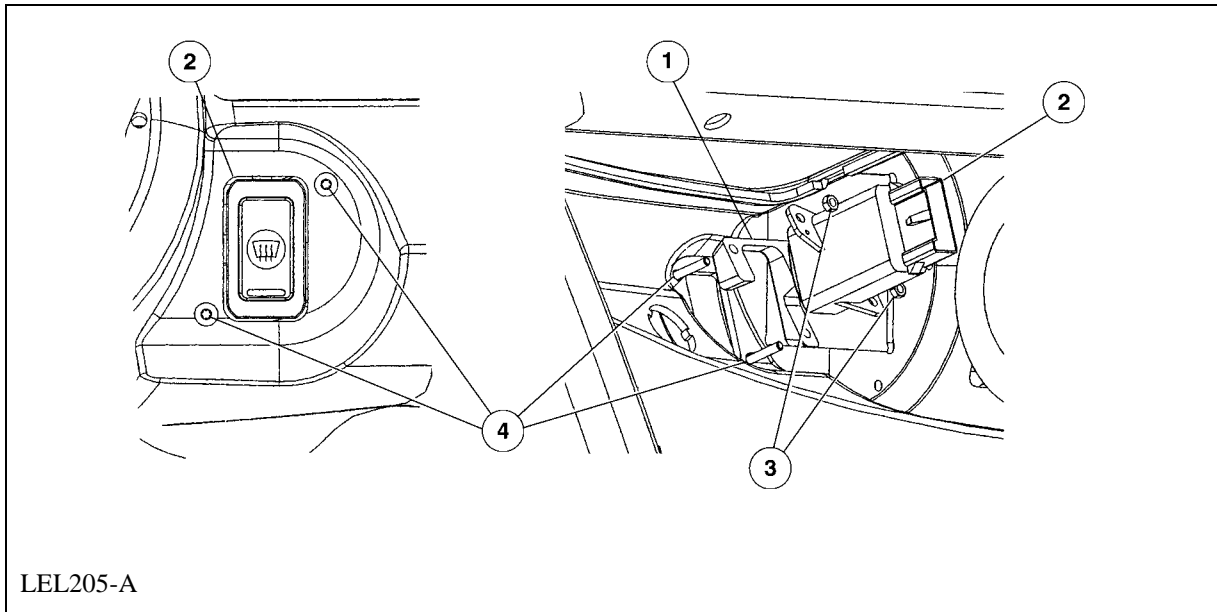

Item	Part Number	Description
1	--	Heater/defogger switch spacer
2	--	Heater/defogger switch
3	--	Heater/defogger switch nuts
4	--	Heater/defogger switch screws

Removal

1. Remove the scrivet and the RH cowl tray panel.
2. Disconnect the heater/defogger switch electrical connector
3. Remove the heater/defogger switch nuts.
4. Remove the heater/defogger switch screws, heater/defogger switch and spacer.

Installation

1. Reverse the removal procedure.
2. Tighten the heater/defogger switch nuts to 1.75-2.25N.m (15.4-19.9lb-in.).

Heater/Defogger Contactor

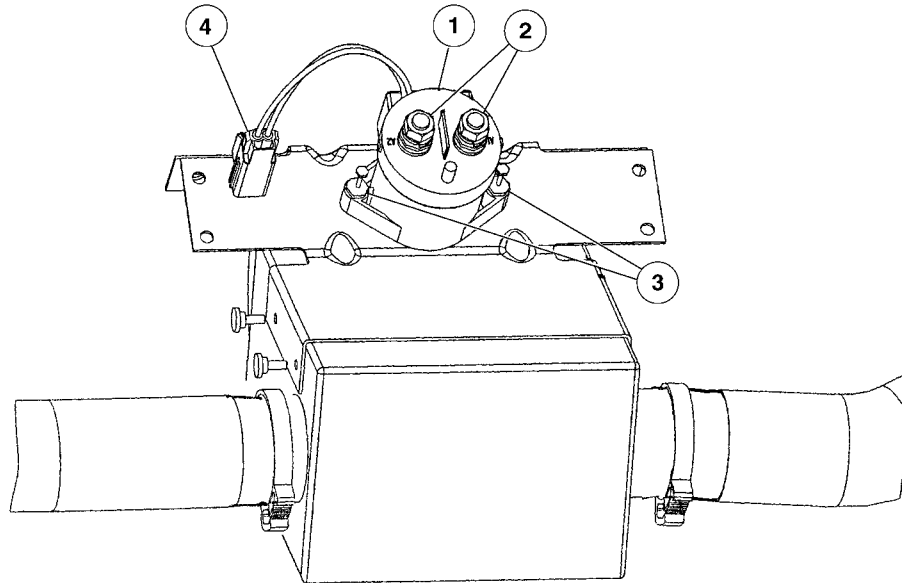

LEL207-a

Item	Part Number	Description
1	--	Heater/defogger contactor
2	--	Heater/defogger contactor cable nuts
3	--	Rivets
4	--	Heater/defogger contactor electrical connector

Removal

1. Turn the vehicle power off. Refer to the [Power Shutdown Procedure](#) in this section.
2. Remove the front fascia. Refer to [Fascia – Front](#) in the Body section.
3. Disconnect the heater/defogger contactor electrical connector.
4. Note the wire locations and remove the heater/defogger contactor cable nuts.
5. Drill out the rivets and remove the heater/defogger contactor.

Installation

1. Reverse the removal procedure.
2. Tighten the heater/defogger contactor cable nuts to 8-10N.m. (71-88lb-in.).

Heater/Defogger Duct and Hose

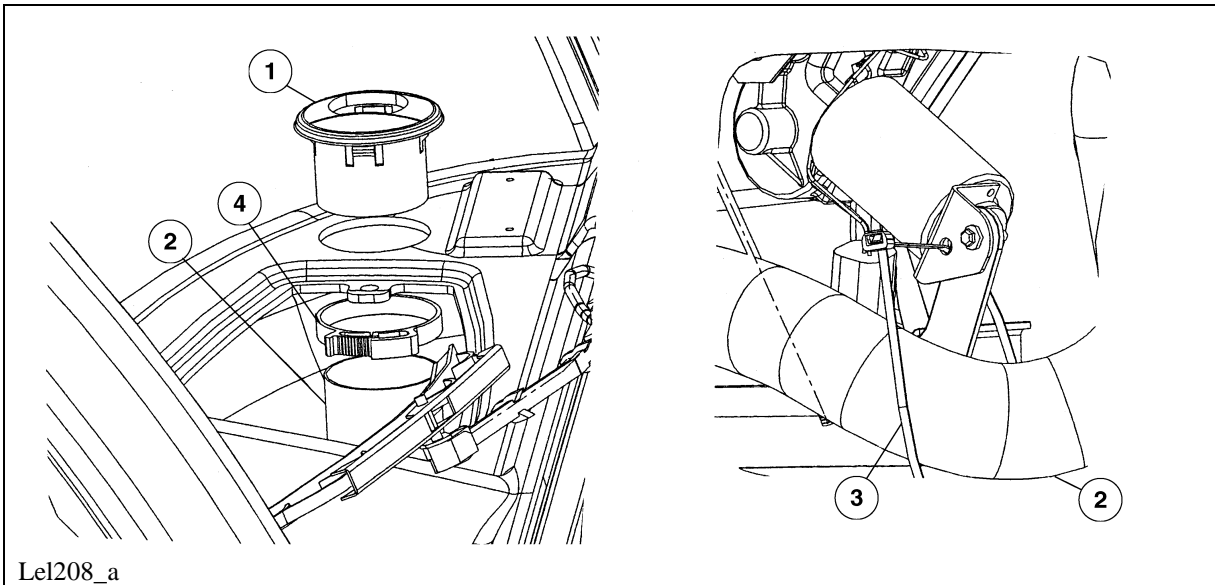

Item	Part Number	Description
1	--	Heater/defogger duct
2	--	Vent hose
3	--	Tie strap
4	--	Nylon clamp

Removal

1. If removing the LH duct and/or hose, remove the front fascia. Refer to [Fascia – Front](#) in the Body section.
2. If removing the RH duct and/or hose, remove the scrivet and the cowl tray panel.
3. Remove the nylon clamp and slide the vent hose off of the heater/defogger duct.
4. If necessary, remove the heater/defogger duct.

5. Remove the nylon clamp and slide the vent hose off of the heater/defogger housing.
6. If removing the LH vent hose, cut and remove the tie strap.
7. Remove the vent hose.

Installation

Reverse the removal procedure.

Power Point, 15A DC/DC

Removal

WARNING!

MAKE SURE THE VEHICLE IS NOT BEING CHARGED.

1. Remove the seat stanchion cover. Refer to [Seat Stanchion Cover](#) in the Body section.
2. Turn the vehicle power off. Refer to the [Power Shutdown Procedure](#) in this section.
3. Remove the scrivet and the RH cowl tray.
4. Disconnect the power point electrical connector.

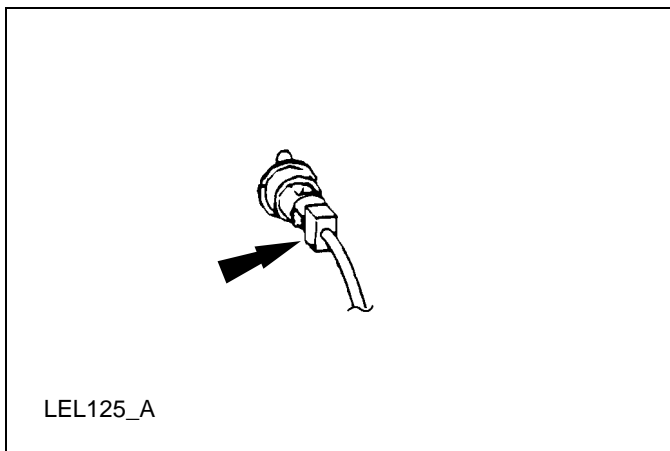

5. Squeeze the two tabs and remove the power point socket.

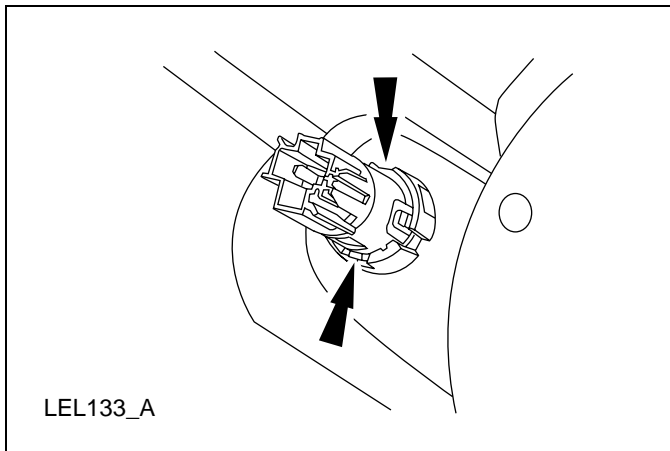

Installation

Reverse the removal procedure.

Electronic Flasher

Removal

WARNING!

MAKE SURE THE VEHICLE IS NOT BEING CHARGED.

1. Remove the four steering column shroud screws and two pushpins and the lower steering column shroud.
2. Remove the electronic flasher.

Installation

1. Reverse the removal procedure
2. Tighten the steering column shroud screws to 2.7-3.7N.m. (23.8-32.7lb-in.)

Temperature Sensor

Removal

WARNING!

MAKE SURE THE VEHICLE IS NOT BEING CHARGED.

1. Remove the seat stanchion cover. Refer to [Seat Stanchion Cover](#) in the Body section.

2. Turn the vehicle power off. Refer to the [Power Shutdown Procedure](#) in this section.
3. Remove the temperature sensor and disconnect the temperature sensor electrical connector.

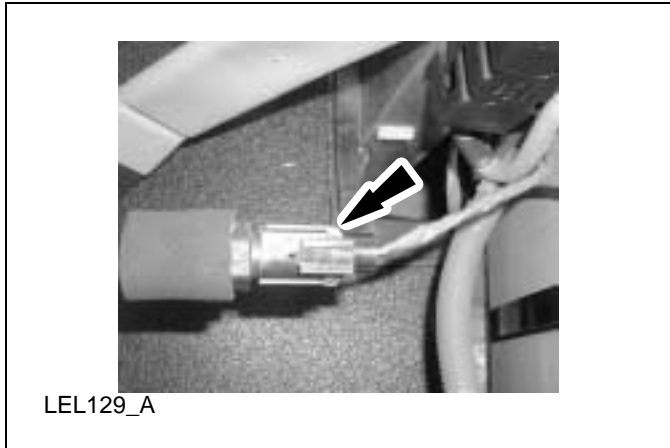

4. Carefully remove the insulator from the switch. If damaged, replace the insulator.

Installation

Reverse the removal procedure.

Switch, Drive Mode Selector

Removal

WARNING!

MAKE SURE THE VEHICLE IS NOT BEING CHARGED.

1. Remove the seat stanchion cover. Refer to [Seat Stanchion Cover](#) in the Body section.
2. Turn the vehicle power off. Refer to the [Power Shutdown Procedure](#) in this section.
3. Remove the scrivet and the LH or RH cowl tray.

4. Disconnect the drive mode selector switch electrical connector from the back of the instrument cluster gauge.

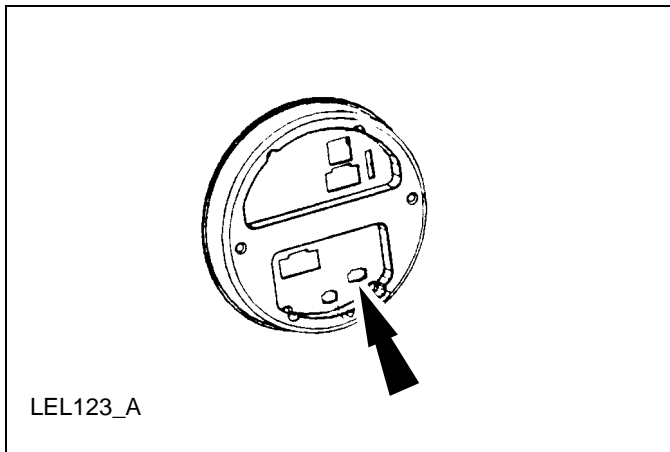

5. Remove the spring clip retainer and the drive mode selector switch.

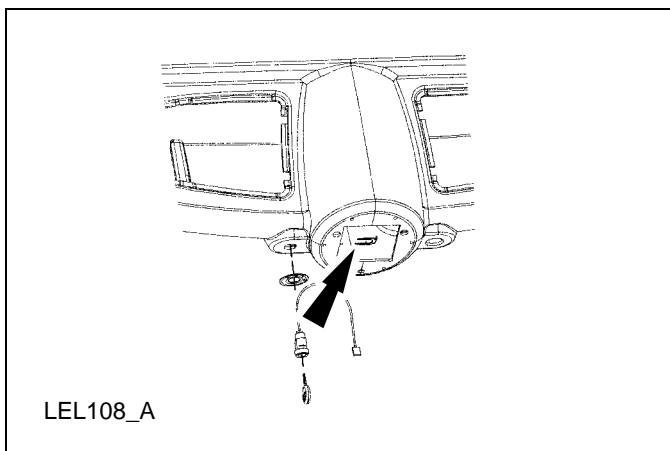

Installation

Reverse the removal procedure.

All locks should be replaced when replacing drive mode selector switch.

Switch, Horn

Removal and Installation

The horn switches are not serviced separate from the steering wheel.

Switch, Multifunction

Removal

WARNING!

MAKE SURE THE VEHICLE IS NOT BEING CHARGED.

1. Remove the seat stanchion cover. Refer to [Seat Stanchion Cover](#) in the Body section.
3. Turn the vehicle power off. Refer to the [Power Shutdown Procedure](#) in this section.
4. Remove the four steering column shroud screws and the steering column shroud.
5. Disconnect the two multifunction switch electrical connectors.

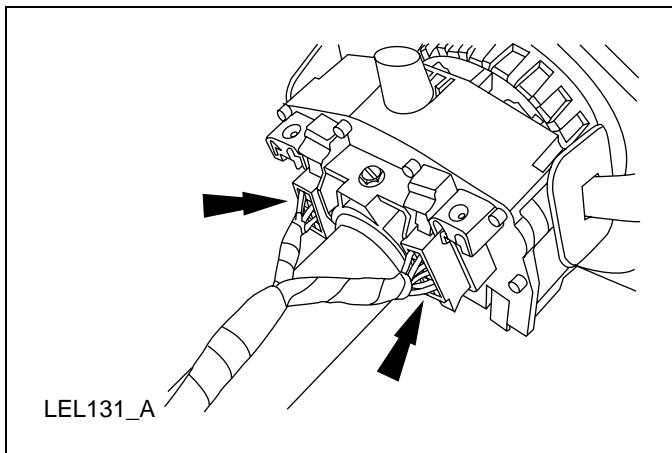

6. Remove the multifunction switch screw.

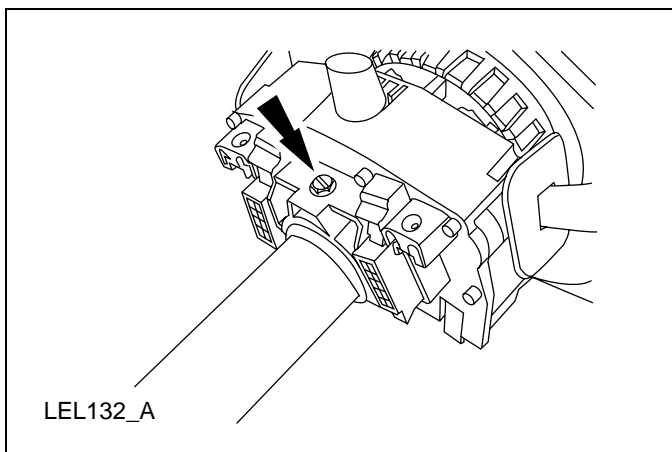

Installation

1. Reverse the removal procedure.

2. Tighten the multifunction switch screw to 2.5-3.7N.m (22.1-32.7lb-in.).
3. Tighten the four steering column shroud screws to 2.7-3.7N.m (23.8-32.7lb-in.).

Switch, Service Disconnect

Removal and Installation

The service disconnect switch can only be replaced with the newer style including the connector. If the vehicle is equipped with the hard wired service disconnect switch the harness will have to be replaced. Refer to [Wiring Harness](#) in this section for the locations of the wiring harnesses and service disconnect switch.

Front Turn Signal

Removal

WARNING!

MAKE SURE THE VEHICLE IS NOT BEING CHARGED.

1. Remove the front fascia. Refer to [Fascia – Front](#) in the Body section.
2. Disconnect the front turn signal electrical connector.
3. Remove the front turn signal bracket bolt and the front turn signal assembly.

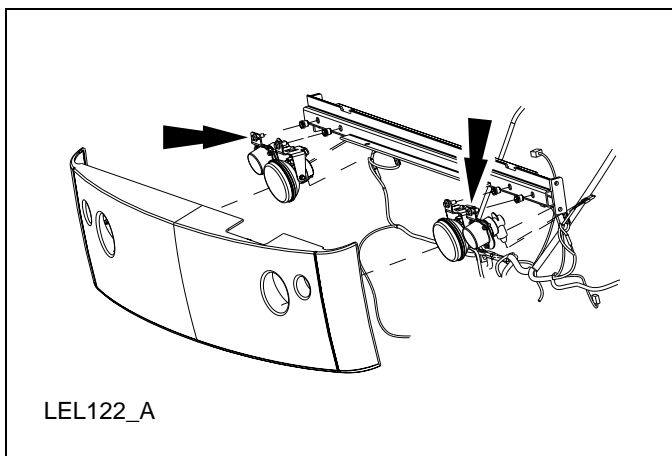

Installation

1. Reverse the removal procedure.
2. Tighten the front turn signal bracket bolt to 24-31N.m. (18-22lb-ft.)

Rear Turn Signal

Removal

WARNING!

MAKE SURE THE VEHICLE IS NOT BEING CHARGED.

1. Unlock and remove the decklid.
2. Remove the six rear bumper bolts and support the rear bumper.
3. Disconnect the rear turn signal electrical connector.
4. Remove the three rear turn signal screws and the front turn signal assembly.

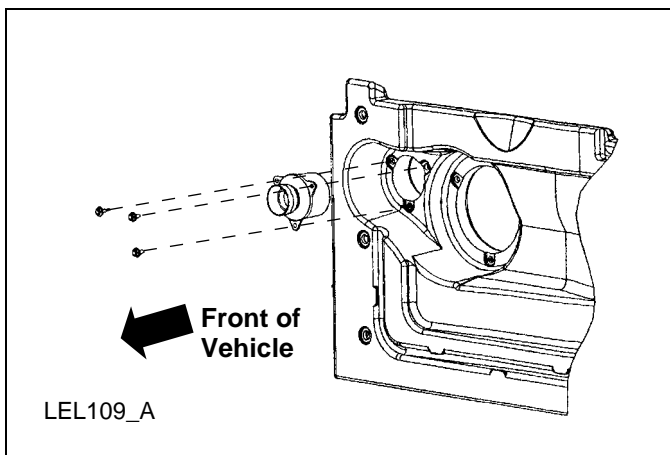

Installation

1. Reverse the removal procedure.
2. Tighten the three rear turn signal screws to 1.9-2.7N.m. (17-23lb-in.)
3. Tighten the six rear bumper bolts to 3.3N.m. (29lb-in.)

Wiring Harnesses – 12V

Removal

WARNING!

MAKE SURE THE VEHICLE IS NOT BEING CHARGED.

Note:

When replacing a wiring harness, contact Hotline for assistance with special steps for modifying the floor panels for additional clearance.

To service the wiring harnesses refer to [Harness Routing](#) in this section for locations of harnesses.

1. Turn the vehicle power off. Refer to the [Power Shutdown Procedure](#) in this section.
2. Remove any necessary components to access the wiring harnesses, electrical connectors and wiring harness fasteners.
3. Remove the applicable wiring harness.

Installation

Reverse the removal procedure.

Wiring Harnesses – 72V (Front of vehicle)

Removal

WARNING!

MAKE SURE THE VEHICLE IS NOT BEING CHARGED.

Refer to [Harness Routing](#) in this section for assistance in locating of harnesses.

1. Unlock and remove the hood.
2. Turn the vehicle power off. Refer to the [Power Shutdown Procedure](#) in this section.
3. Remove the instrument panel. Refer to [Instrument Panel](#) in this section.
4. Disconnect the accelerator potentiometer electrical connector.
5. Remove the tape from the ferrate beads and then from the beads themselves.

6. Remove the leakage sensor lead (10 mm bolt & eyelet) from the front of the vehicle.
7. Disconnect the DC/DC converter from the high voltage wire harness.
8. Disconnect the charger electrical connector.
9. Remove the two rivets from the front passenger side of the vehicle that attach the dash to the frame. This is where the harness is going to be pulled through, so this needs to be done so that the connectors can be feed through.
10. Remove the front passenger side tire.
11. Remove the four rivets and the front passenger wheel well by removing the 4 rivets.
12. Pull the harness between the under body panel and the frame rail in the front passenger wheel well area

Installation

Reverse the removal procedure.

Wiring Harnesses – 72V (Mid vehicle)

Removal

WARNING!

MAKE SURE THE VEHICLE IS NOT BEING CHARGED.

Refer to [Harness Routing](#) in this section for assistance in locating of harnesses.

1. Turn the vehicle power off. Refer to the [Power Shutdown Procedure](#) in this section.
2. Disconnect the temperature sensor electrical connector.

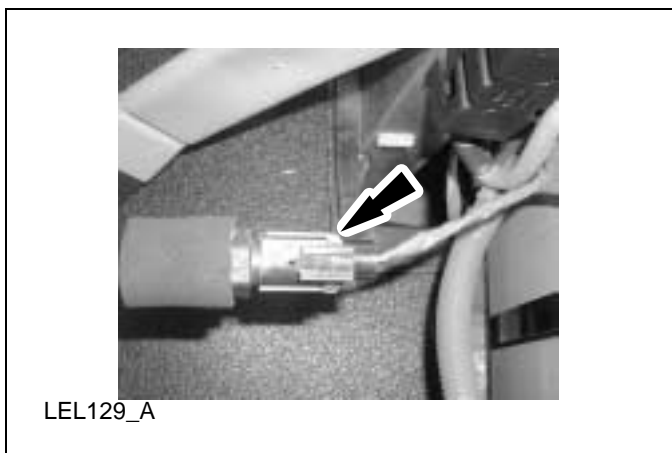

3. Disconnect the contactor electrical connector.
4. Disconnect the battery negative connection from the harness to battery negative 1.
5. Remove the cluster spade from the service disconnect switch fuse box.
6. Remove the DC/DC spade from the service disconnect switch fuse box.
7. Cut the charger connection lead to the service disconnect switch fuse box.
8. Remove the service disconnect switch box.
9. Cut out floor pan where the harness will go through, cut enough out so that the connectors can be feed through.
10. Remove the harness through the floor.

Installation

Reverse the removal procedure.

Wiring Harnesses – 72V (Rear of vehicle)

Removal

WARNING!

MAKE SURE THE VEHICLE IS NOT BEING CHARGED.

Refer to [Harness Routing](#) in this section for assistance in locating of harnesses.

1. Turn the vehicle power off. Refer to the [Power Shutdown Procedure](#) in this section.
2. Remove the rear passenger side tire.

3. Disconnect the motor tachometer/speed sensor electrical connector.

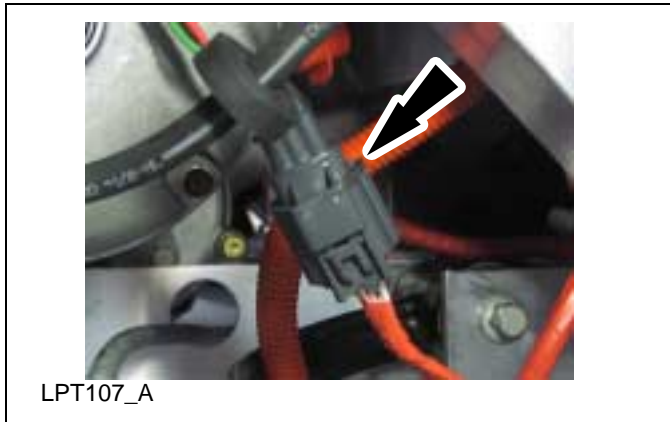

4. Disconnect the 23 pin motor controller electrical connector.
5. Remove the harness through the wheel well.

General Procedures

Battery Charging

WARNING!

THERE ARE GASES AROUND THE BATTERIES THAT CAN EXPLODE IF EXPOSED TO FLAMES, SPARKS, OR LIT CIGARETTES. THE AMOUNT OF GAS IS INCREASED DURING BATTERY CHARGING. AN EXPLOSION COULD RESULT IN PERSONAL INJURY OR VEHICLE DAMAGE.

WARNING!

BATTERIES CONTAIN SULFURIC ACID, WHICH CAN BURN SKIN, EYES, AND CLOTHING, IF CONTACTED.

WARNING!

DO NOT CHARGE THE BATTERIES WITH THE WEATHER ENCLOSURE CLOSED OR THE VEHICLE COVER IN PLACE. A BUILD UP OF HYDROGEN GAS CAN RESULT WHICH CAN EXPLODE. THE CHARGING AREA SHOULD BE WELL VENTILATED.

CAUTION:

If the vehicle is allowed to sit in conditions of -6°C (20°F) or less with a state of charge of 20% (one bar showing on gauge) or less, the batteries could freeze. Allowing the batteries to freeze may cause permanent damage to the batteries and permanently reduce their

capacity. In cold conditions, place the vehicle in an area greater than 0°C (32°F) and allow it to warm up before charging. Never charge the vehicle if the batteries may be frozen. Allow the batteries to warm above 0°C (32°F) first, then charge.

CAUTION:

Do not park and leave the vehicle with discharged batteries. The batteries could discharge to the point where damage could occur and the battery charger will not charge.

Note:

Make sure the service disconnect switch is on the ON position when charging.

To recharge the vehicle batteries:

Use only the GFCI cord supplied with the vehicle. If the GFCI cord does not fit the receptacle, have a qualified electrician install the proper outlet.

Note:

The outlet must be properly installed and grounded in accordance with all local codes and ordinances.

1. Park the vehicle within GFCI charger cord length of a 120 volt AC 15A grounded 3-prong wall outlet.
2. Place the key in the black dot (off) position, remove the key and set the parking brake.

Note:

Make sure the power point, if equipped, is not in use and the hazard lamps are not in use.

3. Plug the GFCI charger cord into the 120volt AC 15A grounded 3-prong wall outlet. Do not use any plug adapters or extension cords to make the electrical connection.

4. Open the charge inlet access door. Make sure that the inlet is clean and dry.



5. Align the GFCI charger cord with the charge inlet and fully insert the plug into the outlet.



6. Verify the POWER indicator is illuminated on the GFCI charger cord. Also, the battery charge indicator on the instrument panel cluster will illuminate during the charging process.

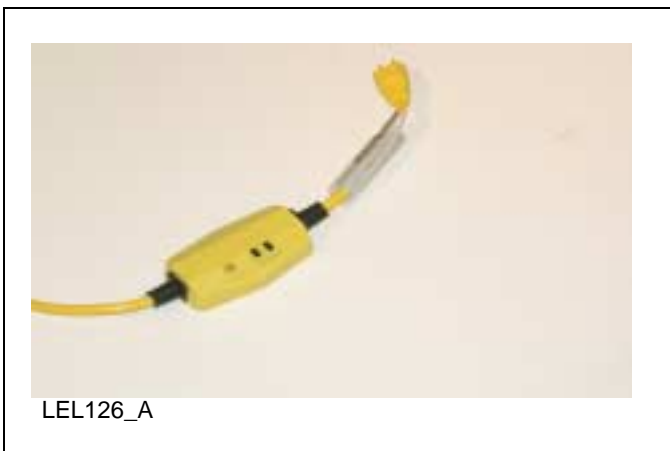

Note:

The humming noise you will hear is the transformer on the charger, which will operate regardless of whether the vehicle is accepting the charge.

Note:

If the charge indicator fails to display make sure the service disconnect switch is in the “ON” position.

To stop charging the vehicle batteries:

1. Push the TEST button on the GFCI charger cord. Verify the power indicator on the GFCI is off.
2. Disconnect the GFCI charger cord from the wall outlet.
3. Disconnect the GFCI charger cord from the charge inlet.
4. Close the charge inlet access door.
5. Store the cord in a safe and dry location.

Vehicle Storage -- Battery

WARNING!

TO AVOID SERIOUS INJURY OR DEATH NEVER PERFORM ANY VEHICLE SERVICE OR MAINTENANCE WHILE THE ELECTRICAL LEAKAGE WARNING IS ILLUMINATED REFER TO ELECTRICAL LEAKAGE DETECTION IN THIS SECTION AND RESOLVE THE LEAKAGE CONDITION PRIOR TO BEGINNING OTHER REPAIRS.

The service disconnect switch (see below) is located either under the driver seat cushion or toward the center of the vehicle behind the parking brake lever within the seat stanchion. The front of the seat stanchion cover should be removed to access the service disconnect switch and the fuse holders on vehicles with the switch located behind the parking brake lever. It is not encouraged to blindly reach down through the opening on top of the driver's side seat stanchion cover when the cushion is removed.

The vehicle can be stored for 14 days with the service disconnect switch on. This assumes a full charge when stored. If 14 days is exceeded or the batteries were not fully charged prior to storing the vehicle the batteries may be severely discharged resulting in permanent damage. This would reduce the batteries capacity and vehicle range.

The vehicle can be stored with the service disconnect switch off for six months if starting with a full charge; however, the vehicle should be charged monthly if possible. With the service disconnect switch in the off position, there is a minimal draw from the vehicle components. The battery self discharge determines the storage time. This is less than 5% per month at temperatures between 4 and 21°C (40° and 70° F). The self-discharge rate increases slightly at higher temperatures. If the batteries are nearly discharged then they may freeze at 0°C (32°F) and below. This will cause severe damage that may even cause battery case damage and leakage of the electrolyte and the inability to operate the vehicle.

When storing the neighbor:

1. Make sure the batteries are fully charged. Refer to [Battery Charging](#) in this section.

2. If storing the vehicle for more than 14 days toggle the service disconnect switch to the OFF position.

Switch shown in the “OFF” position

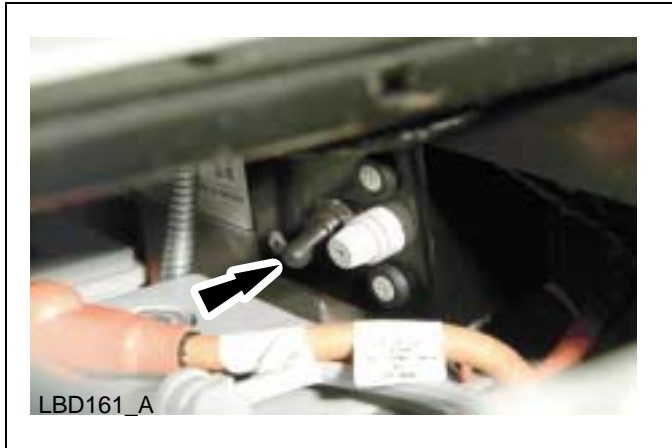

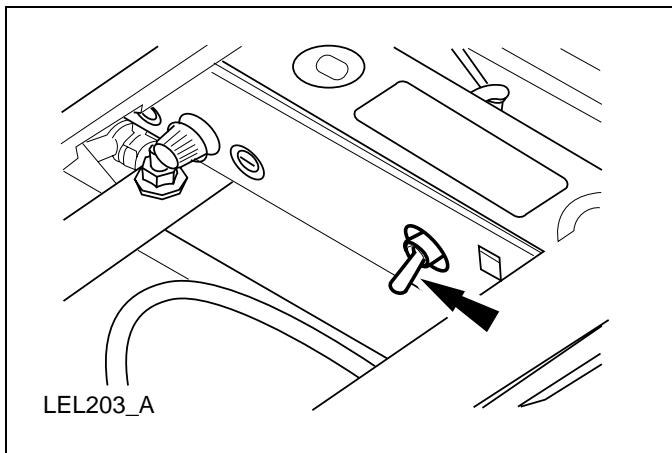

Switch shown in the “ON” position

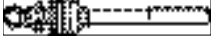

Power Shutdown Procedure

Required Tools

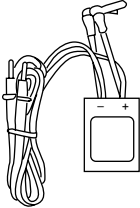
High Voltage Insulated Gloves 100-F036 or Equivalent		Battery Post Torque Wrench 307-026 or Equivalent	
Battery Terminal Cap Opener 418-F215		Face Shield 100-F035 or Equivalent	
Capacitor Discharge Tool 418-F213		73 Digital Multimeter (DVOM) 105-R0051 or Equivalent	

Note:

This procedure is designed to lower the voltage present on the vehicle and reduce the risk of shock or hazard. At the end of this procedure, you will have split the battery pack into three 24V sub-units.

Note:

Continue to use all appropriate high voltage safety procedures when working on a vehicle.

1. Remove the seat stanchion cover. Refer to [Seat Stanchion Cover](#) in the Body section.

2. Toggle the service disconnect switch to the OFF position and wait one minute. Refer to schematic item number 5.

Switch shown in the “OFF” position

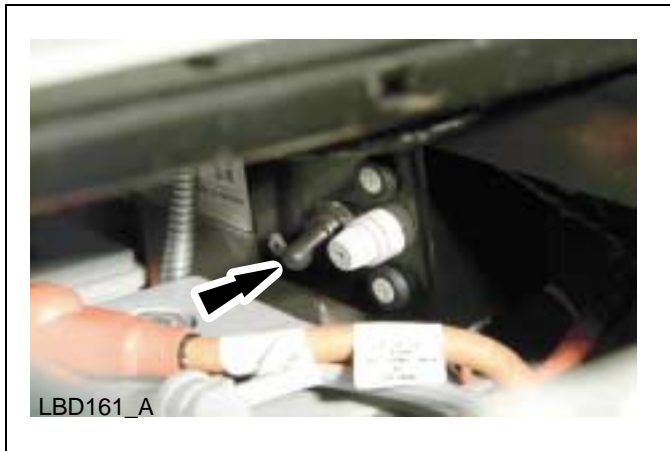

Switch shown in the “ON” position

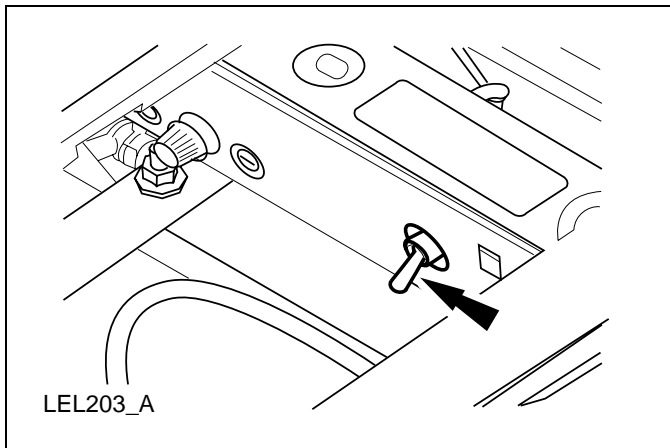

3. Connect the Capacitor Discharge Tool to the DVM. Set the DVOM for DC volts.

WARNING!

THE BATTERY PACK CONTAINS HIGH-VOLTAGE COMPONENTS AND WIRING. HIGH-VOLTAGE INSULATED SAFETY GLOVES AND FACE SHIELD MUST BE WORN WHEN PERFORMING THE FOLLOWING STEPS. FAILURE TO FOLLOW THIS WARNING MAY RESULT IN SEVERE PERSONAL INJURY OR DEATH.

WARNING!

THE BATTERY PACK ASSEMBLY CAN DELIVER IN EXCESS OF 72 VOLTS OF DC POWER. IMPROPER HANDLING OF THE BATTERY PACK CAN RESULT IN INJURY OR FATALITY. ONLY AUTHORIZED PERSONNEL TRAINED TO WORK

WITH BATTERY PACK COMPONENTS ARE PERMITTED TO HANDLE THE BATTERIES.

WARNING!

MAKE SURE THE VEHICLE IS NOT BEING CHARGED.

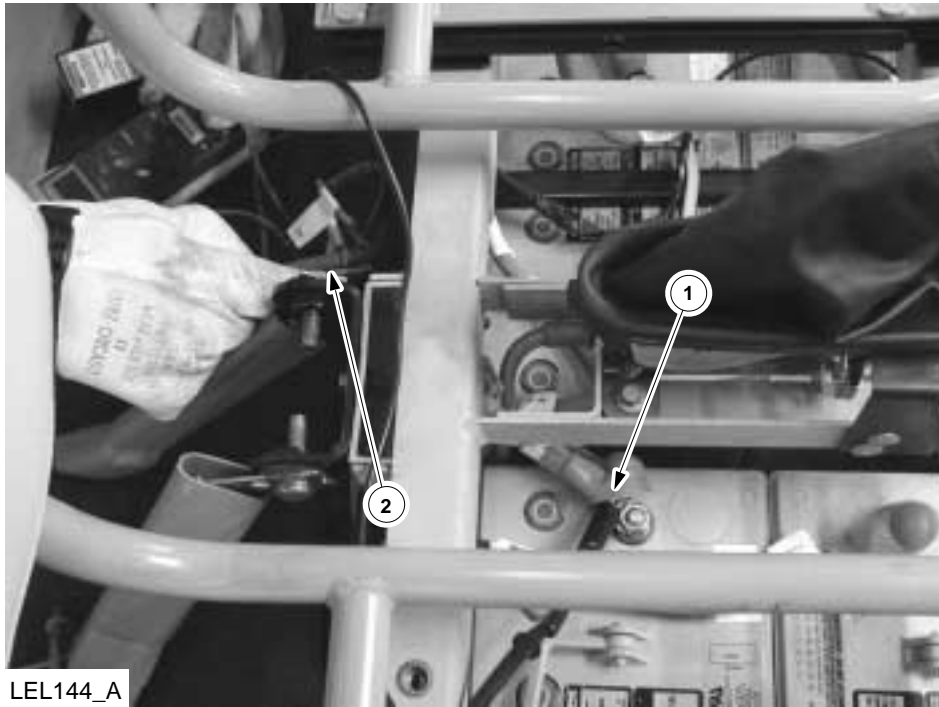

LEL144_A

Item	Description
1	Negative Probe of DVOM to B- (battery negative, labeled "BATT 1 NEG").
2	Positive Probe of DVOM to Load Side of 10-Amp Controller Circuit Fuse.

To discharge the motor controller:

4. Touch the negative probe of the DVOM to the B- (battery negative, which is labeled "BATT 1 NEG").
5. Touch the positive probe of the DVOM to the load side of the 10-amp fuse for the motor controller circuit. This will be the spade connector closest to the front of the fuse holder and it is labeled "GAUGE/MTR-CNTR".
6. The DVOM will display any voltage present. Repeat steps 4 and 5 if DVOM reads more than 0 volts.

To discharge the DC/DC converter 1 (standard) or DC/DC converter 2 (optional):

7. Touch the negative probe of the DVOM to the B- (battery negative, which is labeled “BATT 1 NEG”).
8. Touch the positive probe of the DVOM to the load side of the 10-amp fuse for the DC/DC circuit. This will be the spade connector closest to the front of the fuse holder and it is labeled “DC/DC”.
9. The DVOM will display any voltage present. Repeat steps 7 and 8 if DVOM reads more than 0 volts.
10. Disconnect the battery cables at locations (3) and (4) and wrap the terminals on the cables with electrical tape.

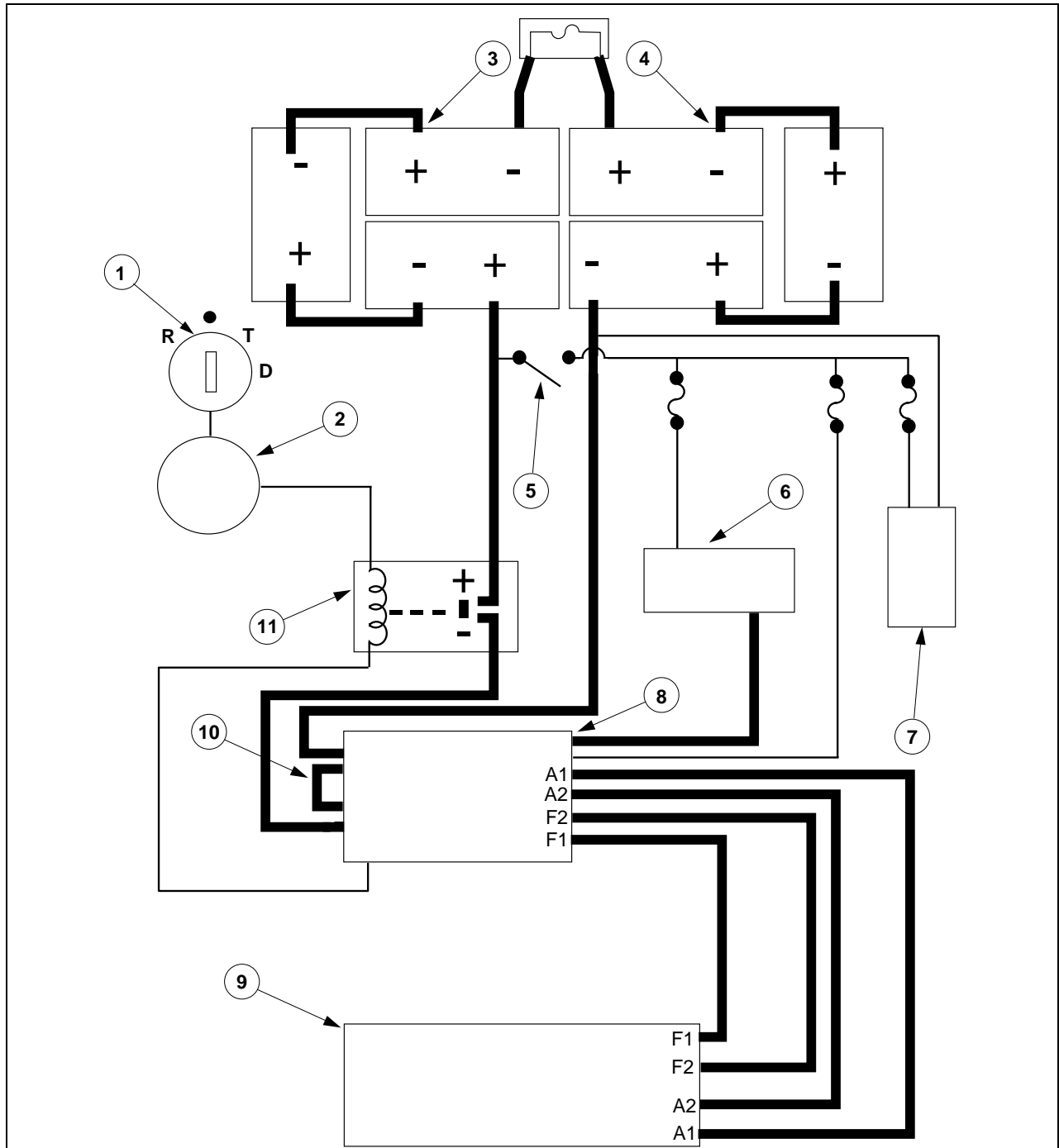

LEL107_A

Item	Description
1	Drive Mode Selector Switch
2	Instrument Cluster Gauge
3	Battery Pack Positive Cable

4	Battery Pack Negative Cable
5	Service Disconnect Switch
6	DC/DC Converter 1 (standard)
7	Charger
8	Motor Controller
9	Motor
10	Motor Controller 23-Pin Connector
11	Contactors

Battery Water Reminder Indicator Resetting (Flooded Batteries Only)

Caution:

If the vehicle is equipped with flooded batteries, the instrument cluster gauge must be programmed for flooded batteries. Damage to the batteries can occur if the battery type is incorrectly programmed. Refer to [Battery Type Reprogramming](#) in this section.

Note:

The battery water reminder function of the instrument cluster gauge must be reset whenever the battery water has been checked and filled. The indicator will illuminate every 300miles (483kms). Battery electrolyte levels should be checked every 300 miles (483kms) or monthly, whichever comes first. The only time the battery water indicator can be reset is when the key is in the R (Reverse) position, the instrument cluster gauge is in the flooded battery mode and the battery water reminder indicator is on.

1. Turn the key to R (Reverse) position.
2. Press and hold the Select/Reset button for over 3 seconds.
3. Turn the key to the OFF (black dot) position.

Battery Type Reprogramming

CAUTION:

If the type of battery (flooded to gel, gel to flooded) is being changed the instrument cluster gauge must be reprogrammed to avoid battery pack damage. The charging rate differs between type of battery and the battery water reminder indicator must be turned on for flooded type batteries.

1. With the key in the OFF (black dot) position, press and hold down the Select/Reset button.
2. Turn the key to the D (Drive) position.
3. Release the Select/Reset button.
4. Turn the key to the R (Reverse) position.
5. Press and release the Select/Reset button to alternate between the flooded and sealed battery modes.
6. Turn the key to the OFF (black dot) position. The gauge will automatically exit the reprogramming mode after 10 seconds or exit immediately by pressing the Select/Reset button.

Headlamp Adjustment

1. Park the vehicle on a level surface approximately 7.6m (25ft.) from a vertical wall or screen directly in front of it.

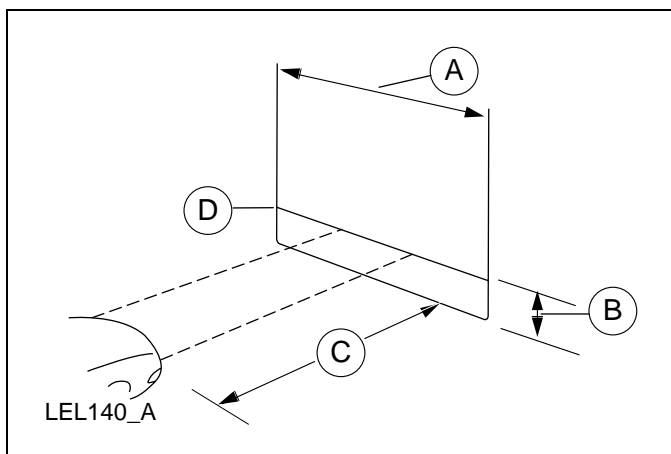

- A. Eight feet.
- B. Height of top of lamp beam to ground.

- C. Twenty five feet
 - D. Horizontal reference line.
2. Turn on the headlamps to illuminate the wall or screen.
 3. The top of the headlamp beam area should be between 2' – 2' 3" above the ground.
Adjust the headlamp adjustment nut until the beam is within this specification.



LEL138_A